

Solution & Servo Drive

Active Cube



BONFIGLIOLI

Bonfiglioli: Specific Solutions for Power Transmission and Motion Control

Product diversification, process automation, and quality have enabled Bonfiglioli to play a leading role in the industry. Bonfiglioli's policy focuses on integrated solutions, competence and innovative technology as key factors, indispensable to ensure customer satisfaction, while production is aimed at achieving the highest standards.

Bonfiglioli product portfolio aims at meeting the toughest and most sophisticated requirement for Industrial Process and Automation Solution and for Mobile Equipment Solutions.





Industrial equipment applications



**BONFIGLIOLI
RIDOTTORI**

Representing Helical, Bevel and Worm Gearmotors and Gear Units



**BONFIGLIOLI
VECTRON**

Representing AC drives

Mobile equipment applications



**BONFIGLIOLI
TRASMITAL**

Representing Planetary Gearmotors and Gear Units

Introduction	4
Overview	5
ACU201 series - Designation	8
ACU401 series - Designation	9
Technical features	10
General technical data	12
ACU201 - Technical data	13
ACU401 - Technical data	15
Inverter selection and dimensioning	20
Options modules	22
Interface modules	24

Communication modules	27
Expansion modules	32
Engineering software	45
Function highlights	47
Automation functions and features	49
Motion functions	51
Servo package	53
Mounting	59
Accessories	67
Worldwide	80



The Bonfiglioli **Active Cube** series is designed to enable you to maximize the opportunities in machine automation.

Extensive motor controls and functionality allow Active Cube to be used in the design of effective and easy automation solutions for a wide variety of industrial machinery and plants.

Outstanding performance in terms of accuracy and response time put Active Cube in the high technology end of the Bonfiglioli Vectron drives range.

The range includes both 1phase and 3phase units, 230V and 400V supply, with the 3 phase product available up to 132kW.

Active Cube includes many features making it suitable for universal use, both as an effective "System drive", and also as a "Servo drive", able to fulfil the requirements of the majority of motion control applications.

Integrated and extensive logic functions give to Active Cube users the possibility to easily and effectively re-arrange drive routines. Brand new functionality can be utilized to tailor the drive to their specific control needs, thus achieve optimal solutions.

Process and machine safety needs are catered for in Active Cube, thanks to the "safe oriented" functions included in the standard drive.

Communication with programmable logic controllers, PC's and industrial display systems is ensured by the wide set of Fieldbus protocols available, while the Bonfiglioli proprietary System bus network allows extremely fast and reliable dialogue for synchronization and/or data exchange with other Bonfiglioli drives in the system.

When considering "servo" applications, Active Cube benefits from the full compatibility with the extensive program of Bonfiglioli synchronous servomotors and accessories (BTD and BCR series), which together provide the possibility of a total Bonfiglioli "servo system".

VPlus engineering and configuration software includes advanced and effective tools for diagnostics and troubleshooting: real oscilloscope analyzer, variable monitoring window; and dashboard for most important process measures are just a few examples.

Technical support is a key element in the Active Cube program, therefore your local Bonfiglioli Drive Service Centre is at your disposal to help and support your engineering department during machine and system requirements analysis, control system architecture definition, product selection and dimensioning, commissioning and start up.

Bonfiglioli drive range

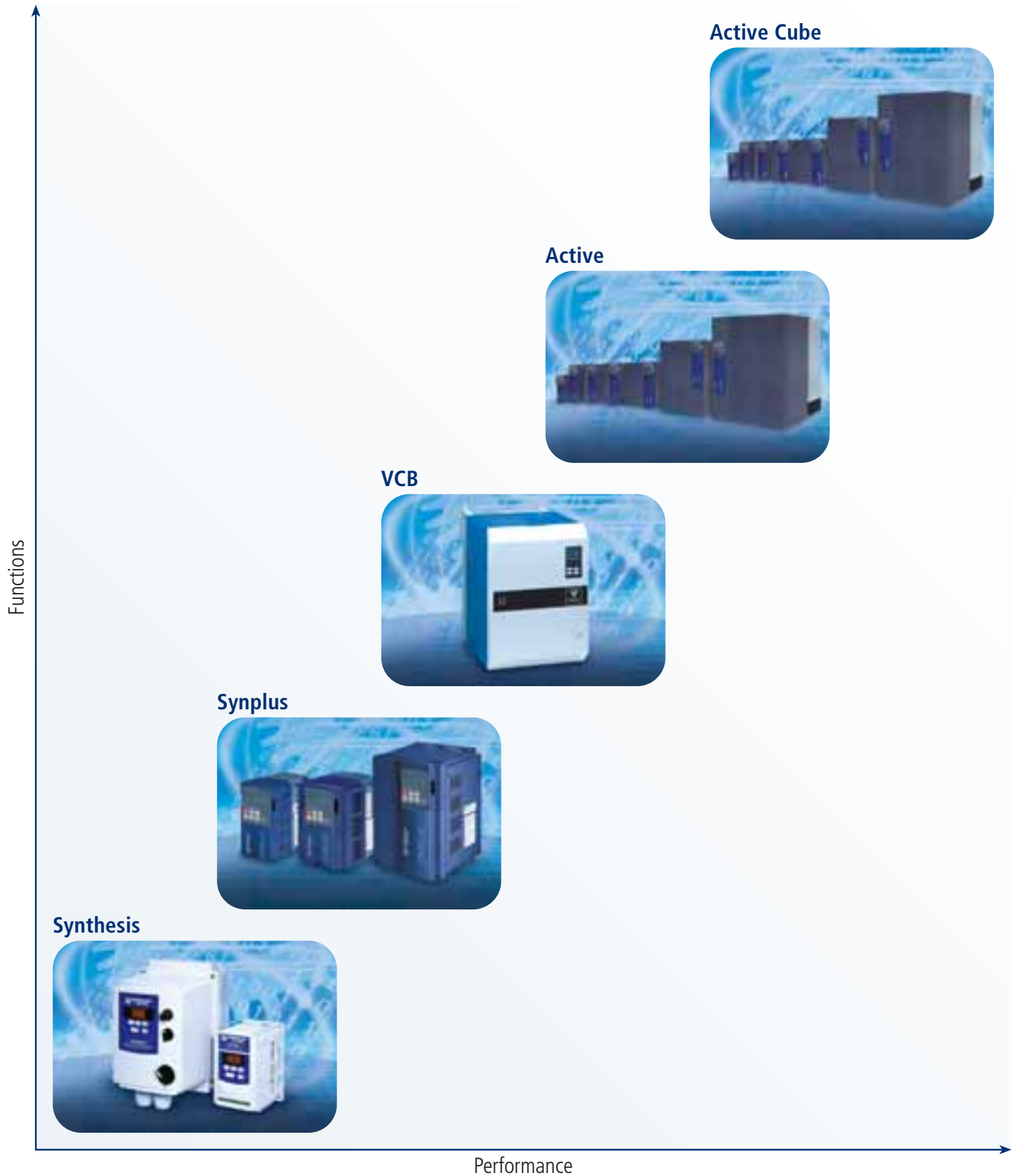

Bonfiglioli drive power/control range

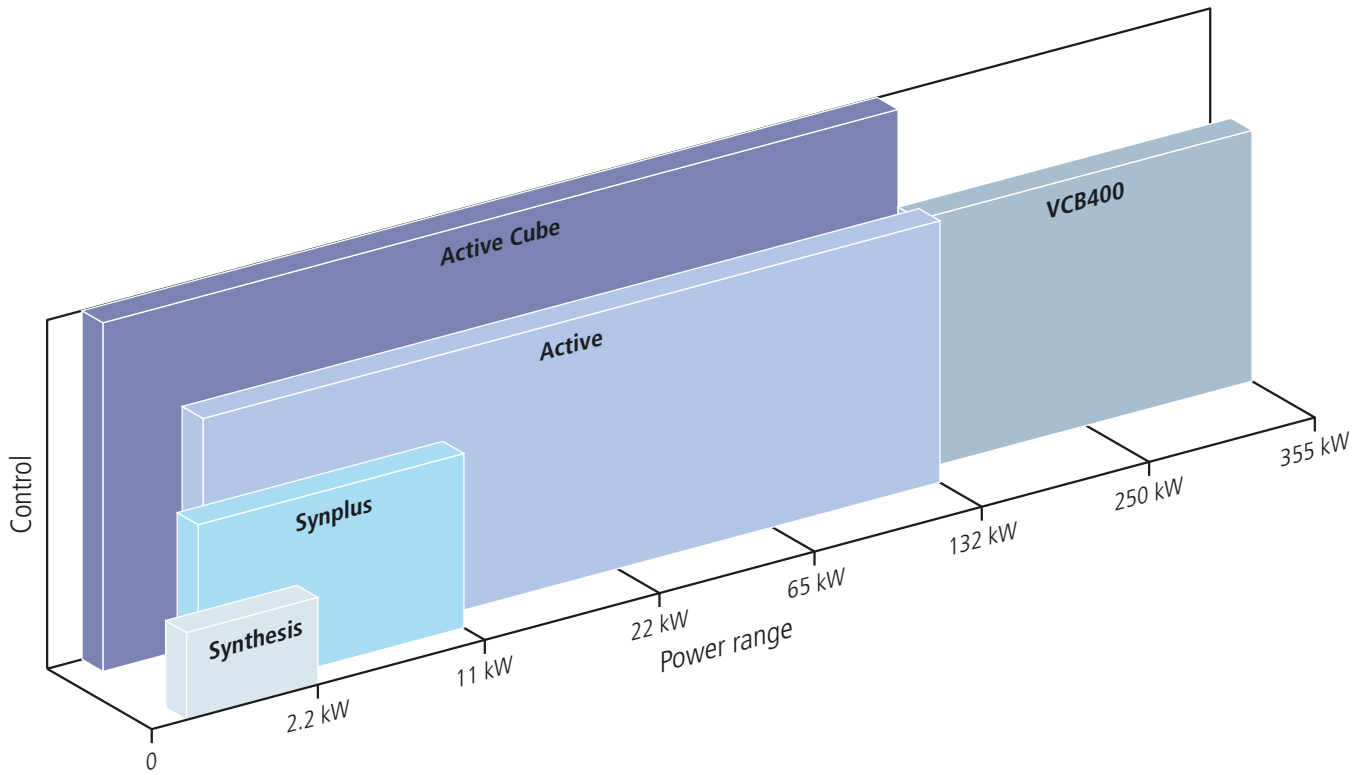

Bonfiglioli "system" range

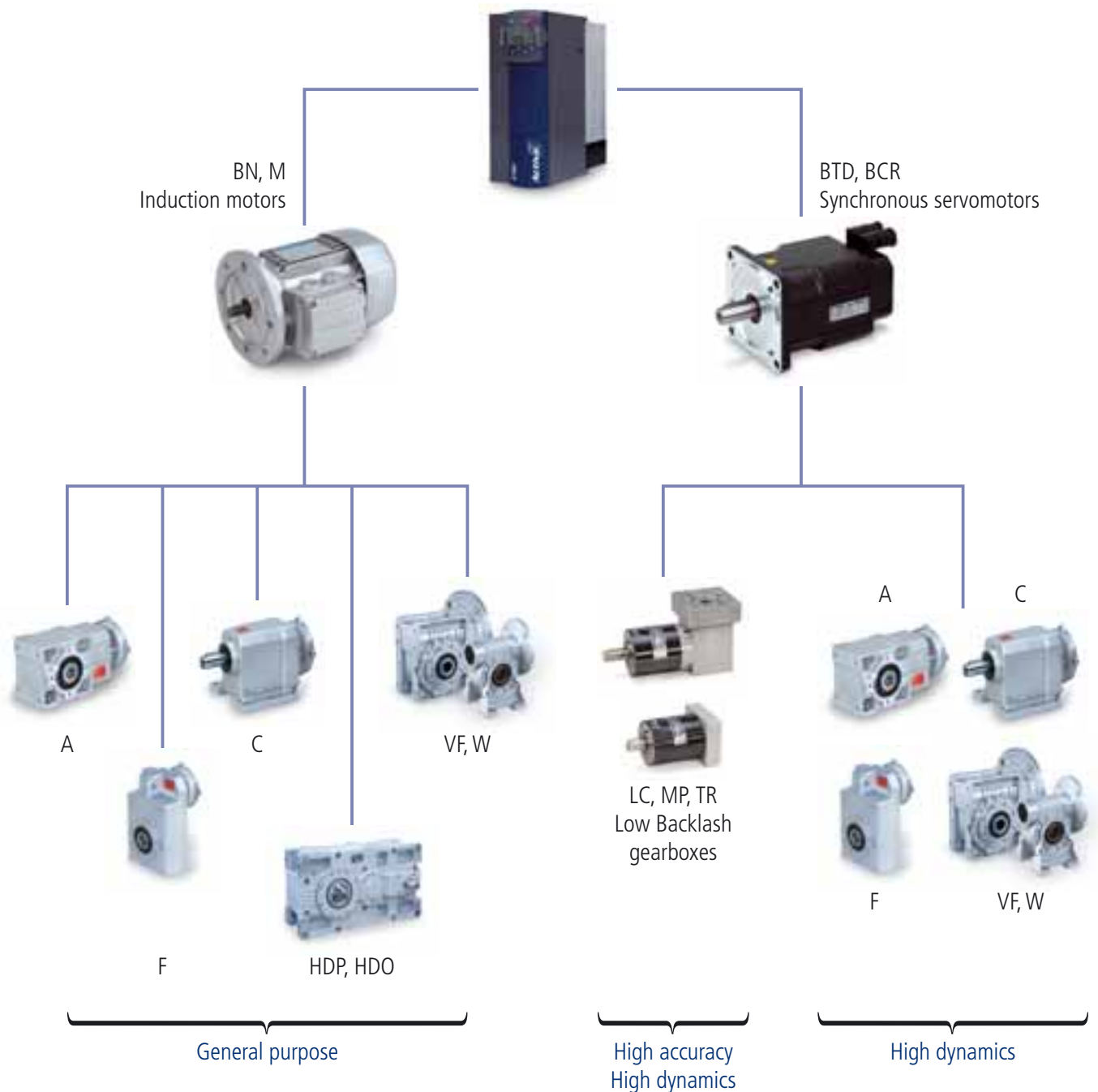

Note

This catalogue concerns Active Cube series and Active Cube accessories. For information about the other products showed in above overview, please refer to relevant catalogues.

STANDARD UNIT

OPTIONS

ACU201 13 F A MPSV EMSYS CMCAN KP500

USER INTERFACE

(blank) = no user interface
KP500 = programming control unit
KP232 = RS232 serial interface

COMMUNICATION MODULES

(blank) = no communication module
CM-CAN = CANopen communication module
CM-PDP = Profibus DP communication module
CM-232 = RS232 serial communication module
CM-485 = RS485 serial communication module

EXPANSION MODULES

(blank) = no expansion modules
EM-SYS = SYSTEMBUS expansion module
EM-IO-... (01, 02, 03, 04) = I/O expansion modules
EM-ENC-... (01, 02, 03, 04, 05) = ENCODER expansion modules
EM-RES-... (01, 02, 03) = RESOLVER expansion modules

INSTALLATION COMPONENTS

(blank) = standard panel mounting kit
MPSV = thru-type mechanical installation kit without fan
MDIN = DIN rail mechanical installation kit
MNVIB = antivibration mechanical installation kit

CONSTRUCTION STYLE

A = style with standard cooling

EMI FILTER

F = internal filter
(blank) = no internal filter

SIZE

01 = 0,25 kW	} Size 1
03 = 0,37 kW	
05 = 0,55 kW	
07 = 0,75 kW	} Size 2
09 = 1,1 kW	
11 = 1,5 kW	} Size 3
13 = 2,2 kW	
15 = 3,0 kW (only 3 ph)	
18 = 4,0 kW (only 3 ph)	} Size 4
19 = 5,5 kW (only 3 ph)	
21 = 7,5 kW (only 3 ph)	
22 = 9,2 kW (only 3 ph)	

INVERTER SERIES

ACU201 = inverter ACTIVE CUBE 1ph/3ph x 200-240 VAC +/- 10%

STANDARD UNIT				OPTIONS			
ACU401	15	F	A	MPSV	EMSYS	CMCAN	KP500
							<p>USER INTERFACE (blank) = no user interface KP500 = programming control unit KP232 = RS232 serial interface</p> <p>COMMUNICATION MODULES (blank) = no communication module CM-CAN = CANopen communication module CM-PDP = Profibus DP communication module CM-232 = RS232 serial communication module CM-485 = RS485 serial communication module</p> <p>EXPANSION MODULES (blank) = no expansion modules EM-SYS = SYSTEMBUS expansion module EM-IO-... (01, 02, 03, 04) = I/O expansion modules EM-ENC-... (01, 02, 03, 04, 05) = ENCODER expansion modules EM-RES-... (01, 02, 03) = RESOLVER expansion modules</p> <p>INSTALLATION COMPONENTS (blank) = standard panel mounting kit MPSV = thru-type mechanical installation kit without fan MDIN = DIN rail mechanical installation kit MNVIB = antivibration mechanical installation kit</p> <p>CONSTRUCTION STYLE A = style with standard cooling</p> <p>EMI FILTER F = internal filter (blank) = no internal filter</p>
SIZE							
01 = 0.25 kW	} Size 1		23 = 11 kW	} Size 4			
03 = 0.37 kW			25 = 15 kW				
05 = 0.55 kW			27 = 18.5 kW	} Size 5			
07 = 0.75 kW			29 = 22 kW				
09 = 1.1 kW	} Size 2		31 = 30 kW	} Size 6			
11 = 1.5 kW			33 = 37 kW				
12 = 1.85 kW			35 = 45 kW				
13 = 2.2 kW			37 = 55 kW				
15 = 3.0 kW	} Size 3		39 = 65 kW	} Size 7			
18 = 4.0 kW			43 = 75 kW				
19 = 5.5 kW			45 = 90 kW				
21 = 7.5 kW			47 = 110 kW				
22 = 9.2 kW		49 = 132 kW					

INVERTER SERIES

ACU401 = inverter ACTIVE CUBE 3ph x 360-480VAC +/- 10%

Hardware

Performance

- High speed control loop and fast response time
- Both "system drive" and "servo drive"
- Optimized combination with Bonfiglioli BTD and BCR servomotor series

Automation

- Small dimensions and "power density" in all sizes
- "Book shape" in smaller sizes for easy integration in automation cabinets
- Integrated "safe Torque Off" function, according to EN954-1 cat.3
- External 24V supply input for control board supply from backup systems
- Motor thermal evaluation
- Position and speed feedback input (encoder/resolver)
- Several mechanical mounting modes available: Din rail mounting, pass through mounting, side mounting
- Proprietary fieldbus (System bus) for fast communication among Bonfiglioli Active Cube drives

Electrical

- Plug in control terminals for easy and fast connection
- Plug in power terminals up to 4kW
- DC link bus for "energy sharing" in multidrive system architectures
- Integral EMI filters (EN 61800-3) up to 9,2kW
- Integrated brake transistor on all sizes

Options and accessories

- Comprehensive set of optional expansion modules, to greatly increase the I/Os and feedback acquisition of the basic equipment
- Comprehensive set of optional communication modules, to connect Active Cube to control devices using industry fieldbus communication protocols
- Multifunction keypad with monitoring and programming functions
- Drive-PC connection kit for advanced configuration with engineering software VPlus
- Teleservice kit for remote diagnosis and maintenance
- Comprehensive power and control cable packs for fast and easy connection of Active Cube to Bonfiglioli BTD and BCR servomotors

Software

Flexibility

- Control both of asynchronous and synchronous actuators
- Full set of operation modes, freely selectable:
 - Servo synchronous control with resolver feedback
 - Field oriented (vector) control with speed/sensor
 - Sensorless field oriented (vector) control
- Flexible assignment of digital inputs and outputs to control software module variables
- "Motor chopper" function to increase braking power without brake resistors
- 4 independent data sets
- Flying restart

Automation

- Easy and powerful engineering software for parameter setting, diagnostic and aided commissioning
- Integrated powerful logic functions
- Speed and position synchronization between drives through Systembus
- Master/slave operation
- Electronic gear
- PI control with advanced derivative control
- Intelligent current limits
- Motor potentiometer control via digital input, control unit and communication interface

Servo

- Very accurate and reliable speed and position control
- Integrated motion software including homing functions, units converter, programmable motion blocks, to design and test even complex motion profiles
- Rotary table function
- S-ramps selection with separate adjustable acceleration/deceleration and jerk limitation
- Preset values for Bonfiglioli BTD/BCR servomotors

Safety

- Mains voltage monitoring and "bridging" function to overcome short time power failures
- Overload protection and best switching frequency automatic adjustment
- Safe Torque Off function

Diagnosis

- Phase monitoring
- Mean and peak values storage

Advanced application functions

- Advanced brake release control (lifting applications)
- Spindle control up to 1000Hz with "tool change" positioning
- "Traverse" function for winders
- "Index" function for enhanced sensorless synchronization
- Load detection function

Engineering software

- Easy programming interface
- Real time oscilloscope and variable values monitor for enhanced troubleshooting analysis during the commissioning phase
- Effective and easy management of motion block parameters
- A simple and guided procedure for set up with Bonfiglioli servomotors
- Logic function programming section with 16 functions

Environment

Operating temperature	0°C - 40°C (40°C-55°C with derating)
Environment class	Operation 3K3 (EN60721-3-3) Relative humidity 15%..85%, no moisture condensation
Altitude of installation	Up to 1000m (up to 4000 with derating)
Storage conditions	According to EN50178
Protection degree	IP20

Electrical

Rated mains voltage	ACU201 in the range 184..264V - ACU401 in the range 320..528V
Rated mains frequency	45..66 Hz
Overload current	150% of rated current (200% for 0.25 and 0.37 kW)
Peak current	200% of rated current for most ratings
Electric protection	Short circuit / Earth fault proof
Braking transistor	Built-in on standard devices

Standards

CE conformity	Low voltage directive 73/23/EEC and EN50178 / DIN VDE 0160 and EN61800
Interference immunity	According to EN 61800-3 for use in industrial environments
UL approval	UL marked, according to UL508c

ACU201 - Technical data

Active Cube

13

From 0.25 to 3.0 kW

ACU201-				Size 1					Size 2		
				01	03	05	07	09	11	13	15
				F					F		
				A					A		
Output, motor side	Rated motor current output	I_n	A	1.6	2.5	3.0	4.0	5.5	7.0	9.5	12.5
	Rated motor voltage output	U_n	V	3 x (from 0 to mains voltage)							
	Overload current	I_{pk}	A	3.2	5.0	4.5	6.0	7.3	10.5	14.3	16.2
	Recommended rated motor power	P_n	kW	0.25	0.37	0.55	0.75	1.1	1.5	2.2	3.0
	Switching frequency	f_c	kHz	From 2 to 16							
	Rated motor frequency	f_n	Hz	From 0 to 1000							
Input, mains side	Rated mains voltage	U	V	184 ... 264							
	Rated mains frequency	f	Hz	45 ... 66							
	Rated current 3 ph/PE	I	A	1.6	2.5	3.0	4.0	5.5	7.0	9.5	10.5
	Rated current 1 ph/N/PE; 2 ph/PE	I	A	2.9	4.5	5.4	7.2	9.5	13.2	16.5	16.5
General	Short circuit / ground fault protection	-	-	Yes, unlimited							
	Mounting position	-	-	Vertical							
	Protection class	-	-	IP 20 (EN60529)							
	Dimensions Std. A	HxWxD	mm	190 x 60 x 175					250 x 60 x 175		
	Weight (approx.)	m	kg	1.2					1.6		
	Brake unit	-	-	internal brake transistor							
Options & accessories Environment	Cooling temperature	T_n	°C	From 0 to 40 (3K3 DIN IEC 721-3-3)							
	Relative air humidity	-	%	From 15 to 85, non-condensing							
	Input line choke	-	-	external (depending on mains supply)							
	EMI filter	-	-	internal Class A (EN 61800-3); external Class B							
	Digital control unit	-	-	yes							

From 4.0 to 9.2 kW

ACU201-				Size 3		Size 4	
				18	19	21	22
				- or F		-	
				A		A	
Output, motor side	Rated motor current output	I_n	A	18.0	22.0	32.0	35.0
	Rated motor voltage output	U_n	V	3 x (from 0 to mains voltage)			
	Overload current	I_{pk}	A	26.2	30.3	44.5	51.5
	Recommended rated motor power	P_n	kW	4.0	5.5	7.5	9.2
	Switching frequency	f_c	kHz	From 2 to 16			
	Rated motor frequency	f_n	Hz	From 0 to 1000			
Input, mains side	Rated mains voltage	U	V	184 ... 264			
	Rated mains frequency	f	Hz	45 ... 66			
	Rated current 3 ph/PE	I	A	18	20	28.2	35.6
	Mains fuses 3 ph/PE	I	A	25		35	50
General	Short circuit / ground fault protection	-	-	Yes, unlimited			
	Mounting position	-	-	Vertical			
	Protection class	-	-	IP 20 (EN60529) ⁽⁰⁾			
	Dimensions Std. A	HxWxD	mm	250 x 100 x 200		250 x 125 x 200	
	Weight (approx.)	m	kg	3.0		3.7	
	Brake unit	-	-	internal brake transistor			
Options & accessories Environment	Cooling temperature	T_n	°C	From 0 to 40 (3K3 DIN IEC 721-3-3)			
	Relative air humidity	-	%	From 15 to 85, non-condensing			
	Input line choke	-	-	external (depending on mains supply)			
	EMI filter	-	-	internal Class A (EN 61800-3); external Class B (see table on page 48)			
	Digital control unit	-	-	yes			

Note: (0) = for protection classes higher than IP20 consult your local Bonfiglioli Drives Service Center

From 0.25 to 3.0 kW

ACU401-				Size 1						Size 2		
				01	03	05	07	09	11	12	13	15
				F						F		
				A						A		
Output, motor side	Rated motor current output	I_n	A	1.0	1.6	1.8	2.4	3.2	3.8	4.2	5.8	7.8
	Rated motor voltage output	U_n	V	3 x (from 0 to mains voltage)								
	Overload current	I_{pk}	A	2.0	3.2	2.7	3.6	4.8	5.7	6.3	8.7	11.7
	Recommended rated motor power	P_n	kW	0.25	0.37	0.55	0.75	1.1	1.5	1.85	2.2	3.0
	Switching frequency	f_c	kHz	From 2 to 16								
	Rated motor frequency	f_n	Hz	From 0 to 1000								
Input, mains side	Rated mains voltage	U	V	320 ... 528								
	Rated mains frequency	f	Hz	45 ... 66								
	Rated current 3 ph/PE	I	A	1.0	1.6	1.8	2.4	2.8	3.3	4.2	5.8	6.8
	Mains fuses 3 ph/PE	I	A	6						10		
General	Short circuit / ground fault protection	-	-	Yes, unlimited								
	Mounting position	-	-	Vertical								
	Protection class	-	-	IP 20 (EN60529) ⁽⁰⁾								
	Dimensions Std. A	HxWxD	mm	190 x 60 x 175						250 x 60 x 175		
	Weight (approx.)	m	kg	1.2						1.6		
	Brake unit	-	-	internal brake transistor								
Options & accessories Environment	Cooling temperature	T_n	°C	From 0 to 40 (3K3 DIN IEC 721-3-3)								
	Relative air humidity	-	%	From 15 to 85, non-condensing								
	Input line choke	-	-	external (depending on mains supply)								
	EMI filter	-	-	internal Class A (EN 61800-3); external Class B (see table on page 48)								
	Digital control unit	-	-	yes								

Note: (0) = for protection classes higher than IP20 consult your local Bonfiglioli Drives Service Center

From 4.0 to 15 kW

ACU401-				Size 2		Size 3		Size 4			
				18		19	21	22	23	25	
				F		- or F				-	
				A		A				A	
Output, motor side	Rated motor current output	I_n	A	9.0	14.0	18.0	22.0	25.0	32.0		
	Rated motor voltage output	U_n	V	3 x (from 0 to mains voltage)							
	Overload current	I_{pk}	A	13.5	21.0	26.3	30.3	37.5	44.5		
	Recommended rated motor power	P_n	kW	4.0	5.5	7.5	9.2	11.0	15.0		
	Switching frequency	f_c	kHz	From 2 to 16							
	Rated motor frequency	f_n	Hz	From 0 to 1000							
Input, mains side	Rated mains voltage	U	V	320 ... 528							
	Rated mains frequency	f	Hz	45 ... 66							
	Rated mains current 3 ph/PE	I	A	7.8	14.2	15.8	20.0	26.0	28.2		
	Mains fuses 3ph/PE	I	A	10.0	16.0	25.0		35.0			
General	Short circuit / ground fault protection	-	-	Yes, unlimited							
	Mounting position	-	-	Vertical							
	Protection class	-	-	IP 20 (EN60529) ⁽⁰⁾							
	Dimensions Std. A	HxWxD	mm	250 x 60 x 175	250 x 100 x 200			250 x 125 x 200			
	Weight (approx.)	m	kg	1.6	3.0			3.7			
	Brake unit	-	-	internal brake transistor							
Options & accessories Environment	Cooling temperature	T_n	°C	From 0 to 40 (3K3 DIN IEC 721-3-3)							
	Relative air humidity	-	%	From 15 to 85, non-condensing							
	Input line choke	-	-	external (depending on mains supply)							
	EMI filter	-	-	internal Class A (EN 61800-3); external Class B				external Class B			
	Digital control unit	-	-	yes							

Note: (0) = for protection classes higher than IP20 consult your local Bonfiglioli Drives Service Center

ACU401 - Technical data

Active Cube 17

From 18.5 to 30 kW

ACU401-				Size 5		
				27	29	31
				A		
Output, motor side	Rated motor current output	I_n	A	40.0	45.0	60.0
	Rated motor voltage output	U_n	V	3 x (from 0 to mains voltage)		
	Overload current	I_{pk}	A	60.0	67.5	90.0
	Recommended rated motor power	P_n	kW	18.5	22.0	30.0
	Switching frequency	f_c	kHz	From 2 to 16		
	Rated motor frequency	f_n	Hz	From 0 to 1000		
Input, mains side	Rated mains voltage	U	V	320 ... 528		
	Rated mains frequency	f	Hz	45 ... 66		
	Rated mains current 3 ph/PE	I	A	35.6	52.0	58.0
	Mains fuses 3ph/PE	I	A	50.0		63.0
General	Short circuit / ground fault protection	-	-	Yes, unlimited		
	Mounting position	-	-	Vertical		
	Protection class	-	-	IP 20 (EN60529) ⁽⁰⁾		
	Dimensions Std. A	HxWxD	mm	250 x 200 x 260		
	Weight (approx.)	m	kg	8.0		
	Brake unit	-	-	internal brake transistor		
Options & accessories Environment	Cooling temperature	T_n	°C	From 0 to 40 (3K3 DIN IEC 721-3-3)		
	Relative air humidity	-	%	From 15 to 85, non-condensing		
	Input line choke	-	-	external (depending on mains supply)		
	EMI filter	-	-	external Class B		
	Digital control unit	-	-	yes		

Note: (0) = for protection classes higher than IP20 consult your local Bonfiglioli Drives Service Center

From 37 to 65 kW

				Size 6			
ACU401-				33	35	37	39
				-			
				A			
Output, motor side	Rated motor current output	I_n	A	75.0	90.0	110.0	125.0
	Rated motor voltage output	U_n	V	3 x (from 0 to mains voltage)			
	Overload current	I_{pk}	A	112.5	135.0	165.0	187.5
	Recommended rated motor power	P_n	kW	37.0	45.0	55.0	65.0
	Switching frequency	f_c	kHz	From 2 to 8			
	Rated motor frequency	f_n	Hz	From 0 to 1000			
Input, mains side	Rated mains voltage	U	V	320 ... 528			
	Rated mains frequency	f	Hz	45 ... 66			
	Rated mains current 3 ph/PE	I	A	72	86	105	120
	Mains fuses 3ph/PE	I	A	80	100	125	125
General	Short circuit / ground fault protection	-	-	Yes, unlimited			
	Mounting position	-	-	Vertical			
	Protection class	-	-	IP 20 (EN60529) ⁽⁰⁾			
	Dimensions Std. A	HxLxP	mm	400 x 275 x 260			
	Weight (approx.)	m	kg	20			
	Brake unit	-	-	internal brake transistor			
Options & accessories Environment	Cooling temperature	T_n	°C	From 0 to 40 (3K3 DIN IEC 721-3-3)			
	Relative air humidity	-	%	From 15 to 85, non-condensing			
	Input line choke	-	-	external (depending on mains supply)			
	Brake unit	-	-	internal brake transistor			
	Digital control unit	-	-	yes			

Note: (0) = for protection classes higher than IP20 consult your local Bonfiglioli Drives Service Center

From 75 to 132 kW

				Size 7			
ACU401-				43	45	47	49
				-			
				A			
Output, motor side	Rated motor current output	I_n	A	150.0	180.0	210.0	250.0
	Rated motor voltage output	U_n	V	3 x (from 0 to mains voltage)			
	Overload current	I_{pk}	A	225.0	270.0	315.0	332.0
	Recommended rated motor power	P_n	kW	75.0	90.0	110.0	132.0
	Switching frequency	f_c	kHz	From 2 to 8			
	Rated motor frequency	f_n	Hz	From 0 to 1000			
Input, mains side	Rated mains voltage	U	V	320 ... 528			
	Rated mains frequency	f	Hz	45 ... 66			
	Rated mains current 3 ph/PE	I	A	143	172	208	249
	Mains fuses 3ph/PE	I	A	160	200	250	315
General	Short circuit / ground fault protection	-	-	Yes, unlimited			
	Mounting position	-	-	Vertical			
	Protection class	-	-	IP 20 (EN60529) ⁽⁰⁾			
	Dimensions Std. A	HxLxP	mm	510 x 412 x 351			
	Weight (approx.)	m	kg	45		48	
Options & accessories	Environment						
	Cooling temperature	T_n	°C	From 0 to 40 (3K3 DIN IEC 721-3-3)			
	Relative air humidity	-	%	From 15 to 85, non-condensing			
	Input line choke	-	-	external (depending on mains supply)			
	EMI filter	-	-	external Class B			
	Brake unit	-	-	internal brake transistor			
Digital control unit	-	-	yes				

Choosing the most suitable inverter rating according to application needs is essential to get the best out of Active Cube series. Too small a rating selection may cause unsatisfactory performance and disappointing low productivity of the machine. Selection of too high a rating may increase cost and generate problems in setting motor control.

This section gives some basic hints to determine the optimum rating and model of drive to properly match your application requirements.

Since Active Cube is able to operate both as a high technology "System drive" matched with asynchronous induction motors, and as a "Servo drive", together with synchronous servomotors, two different criteria are proposed:

Asynchronous induction motors (continuous load)

Active cube is driving traditional squirrel cage induction motors (e.g. Bonfiglioli M and BN series). Applications are usually featured by continuous torque supply for long time with occasional smooth overload needs. An example of typical torque profile is shown below.

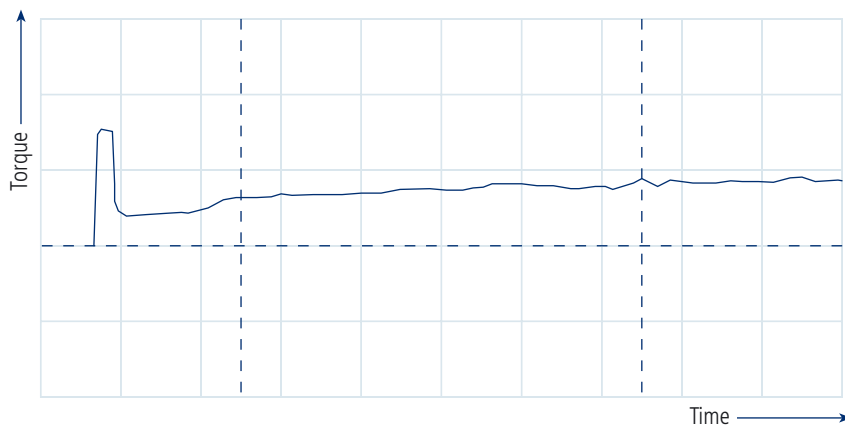

In case of continuous torque, dimensioning and selection of Active Cube can be done through these steps:

- a. Check mains supply phases (1 or 3 phase) and mains supply voltage ($\approx 230V$ or $\approx 400V$)
 - If mains voltage is 1ph-230V or 3ph-230V \Rightarrow ACU201 series
 - If mains voltage is 3ph-400V \Rightarrow ACU401 series
- b. Check if application conditions (ambient temperature, altitude, mains values, ...) are within rated conditions
 - \Rightarrow in case of unusual operating conditions, please refer to DSC for proper product dimensioning.
- c. Check rated motor current for continuous load I_N motor (see motor plate – rated current), overload motor current required I_{MAX} motor and overload time.
 - Select drive rating (see data sheets in "Technical data" section of this catalogue) applying, together, following conditions:
 - $I_N \text{ drive} \geq I_N \text{ motor}$ (rated drive current higher than rated motor current)
 - $I_{pk} \geq I_{MAX} \text{ motor}$ (overload drive current higher than overload motor current)
 - **Overload time $\leq 60\text{secs}$** (overload time shorter than 60secs every 10mins)
- d. EMC protection class required
 - a. A1 \Rightarrow nothing required up to 9,2kW
 - b. A2 \Rightarrow external EMC filter required (see EMC filters in "Accessories" section of this catalogue)
 - c. B \Rightarrow external EMC filter required (see EMC filters in "Accessories" section of this catalogue)
- e. Input, output, feedback acquisition, communication among drives needed?
 - \Rightarrow Select expansion modules (see option modules in "expansion modules" section of this catalogue)
- f. Communication with other electronic devices (PLC, HMI, DCS, ...) needed?
 - \Rightarrow Select communication modules (see option modules in "communication modules" section of this catalogue)
- g. Harmonic problems expected?
 - \Rightarrow Select line choke (see line choke in "Accessories" section of this catalogue)
- h. Is motor equipped with encoder or resolver feedback device? Do we need encoder emulation?
 - \Rightarrow Select feedback module (see option modules in "expansion modules" section of this catalogue)
- i. Is braking resistor required?
 - \Rightarrow Select braking resistor (see braking resistor in "Accessories" section of this catalogue)

Synchronous permanent magnets servomotors (intermittent load)

Active cube is driving high performance synchronous PM servomotors (e.g. Bonfiglioli BTD and BCR series). Applications are usually featured by intermittent very high torque demand for short time. An example of typical torque profile is shown below.

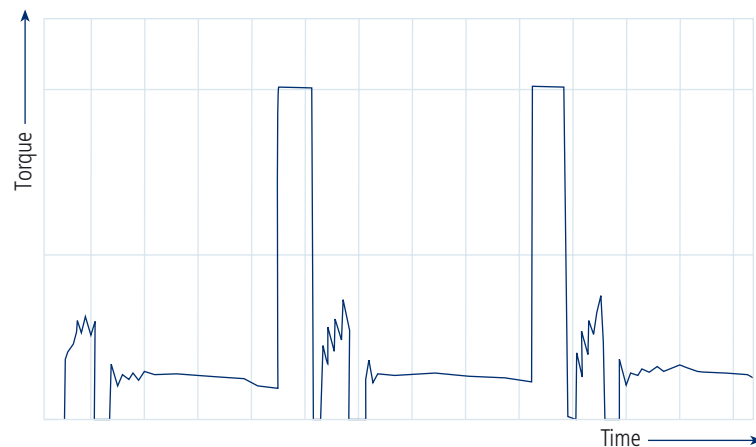

In case of intermittent torque with high peaks, the dimensioning and selection of Active CUbe, can be done through these steps:

- a. Check mains supply phases (1 or 3 phase) and mains supply voltage ($\approx 230V$ or $\approx 400V$)
 - If mains voltage is 1ph-230V or 3ph-230V \Rightarrow ACU201 series
 - If mains voltage is 3ph-400V \Rightarrow ACU401 series
- b. Check if application conditions (ambient temperature, altitude, mains values, ...) are within rated conditions
 - \Rightarrow in case of unusual operating conditions, please refer to DSC for proper product dimensioning.
- c. Calculate RMS torque M_{RMS} and relevant RMS motor current I_{RMS} required, depending on load profile graphic of the application
- d. Calculate motor peak torque M_{MAX} out of load profile graphic of the application and resulting peak current required I_{MAX}
- e. Select the drive matching together following conditions:
 - $I_n \text{ drive} \geq I_{RMS} \text{ motor}$ (rated drive current higher than equivalent motor current)
 - $I_{pk} \text{ drive} \geq I_{MAX} \text{ motor}$ (peak drive current higher than PK motor current)
- f. Is Bonfiglioli BTD or BCR servomotor used?
 - Yes: \Rightarrow Select EMRES03 dedicated feedback module (see option modules in "expansion modules" section of this catalogue)
 - No: \Rightarrow Select feedback module (see option modules in "expansion modules" section of this catalogue)
- g. EMC protection class required
 - a. A1 \Rightarrow nothing required up to 9,2kW
 - b. A2 \Rightarrow external EMC filter required (see EMC filters in "Accessories" section of this catalogue)
 - c. B \Rightarrow external EMC filter required (see EMC filters in "Accessories" section of this catalogue)
- h. Input, output, feedback acquisition, communication among drives needed?
 - \Rightarrow Select expansion modules (see options modules in "expansion modules" section of this catalogue)
- i. Communication with other electronic devices (PLC, HMI, DCS, ...) needed?
 - \Rightarrow Select communication modules (see options modules in "communication modules" section of this catalogue)
- j. Harmonic problems expected?
 - \Rightarrow Select line choke (see line choke in "Accessories" section of this catalogue)
- k. Is braking resistor required?
 - \Rightarrow Select braking resistor (see braking resistor in "Accessories" section of this catalogue)

Active Cube is designed to give the highest flexibility in drive hardware to suit every control requirement. Machine designers can select from an extensive range of possible expansion hardware modules that can be fitted directly into the 3 available slots on the standard Active Cube unit. Mounting and connection is fast and easy thanks to onboard fastening devices. Using option modules, Active Cube features and integration ability can be greatly expanded: the number of possible hardware configurations that can be achieved through combinations of different modules is surprisingly high. Build the best hardware configuration of Active Cube for your application!

Hardware modularity



Interface module

Connection of optional control unit KP500, serial interface adapter KP232, or the control unit remotization cable for accessory KPCMK



CM communication module

Connection panel for various communication protocols:

- CM-232, RS232 interface
- CM-485, RS485 interface
- CM-PDPV1, Profibus-DP interface
- CM-CAN, CANopen interface
- Other protocols on request







EM expansion module

Connection panel for adaptation of control inputs and outputs to the various applications on the basis of specific customer requirements:

- EM-IO, analog and digital inputs and outputs, available in 4 variants
- EM-ENC, speed sensor interface, frequency output and system bus, available in 5 variants
- EM-RES, resolver interface, frequency output and system bus, available in 3 variants
- EM-SYS, system bus for Systembus communication (On request, system bus combined with CM-CAN communication module)
- Other customised modules available on request



Option modules can be ordered either separately or together with ACU base unit, as an “extended” power package. The majority of Active Cube option modules can also be used in the Active series, thus allowing drives from both series to be easily used in the same automation system. Select from below the hardware module to customize Active Cube and build a unique drive which best fits to the needs of your application.

		AI	AO	DI	DO	Relay	RF	Speed encoder		System bus
								Type (s)	Zero pulse	
Basic equipment of Active Cube		1²⁾	-	6³⁾	1	1	-	HTL	yes	yes
	EM-IO-01	1	1	3	-	2	-	HTL	yes	yes
	EM-IO-02	1	1	3	-	1	-	HTL	yes	yes
	EM-IO-03	1	2	2	-	1	-	HTL	no	yes
	EM-IO-04	-	-	2	1 ¹⁾	-	-	-	-	yes
	EM-ENC-01	1	-	-	-	-	yes ⁵⁾	TTL & HTL	no	yes
	EM-ENC-02	1	1	-	1 ¹⁾	-	-	TTL & HTL	no	yes
	EM-ENC-03	-	-	-	-	-	-	TTL & HTL	no	yes
	EM-ENC-04	1	1	-	-	1	-	TTL & HTL	yes	no
	EM-ENC-05	1	1	-	-	-	-	TTL & HTL	yes	yes
	EM-RES-01	1	-	-	-	-	yes ⁵⁾	Resolver		yes
	EM-RES-02	1	-	-	-	-	yes ⁶⁾	Resolver		no
	EM-RES-03	1	-	3	2	-	-	Resolver ⁴⁾		yes
	EM-SYS	-	-	-	-	-	-	-	-	yes

- 1) Can be used as digital input alternatively
 - 2) MF11 can be used as digital input alternatively
 - 3) One is used for control enable. DI can be used for encoder 1 if required.
 - 4) EM-RES-03: Resolver and PTC are run through a DSub 9 connector.
 - 5) Repetition frequency without Zero Pulse
 - 6) Repetition frequency with Zero Pulse
- RF: Repetition frequency, speed sensor simulation.
All inputs/outputs are realized with disconnectable terminals

Communication		
	CM-CAN	Connectors realized with DSub 9 plugs
	CM-PDPV1	
	CM-485	
	CM-232	

Communication		
	CM-CAN-T	Without connectors
	CM-PDPV1-T	
	CM-485-T	

Control unit / KP500



The KP500 control unit is equipped with a Parameters Copy function that allows the user to upload parametric values from the inverter to a non-volatile memory installed in the KP500 device, allowing the same values to be subsequently downloaded to another inverter.

The control unit makes it possible to set up the inverter for specific applications and allows the display of the service values of physical and electrical parameters.

The inverter can also be controlled from the control unit for start/stop and frequency reference increase/decrease commands. Since the control unit is not essential for inverter operation it can be connected when the user considers it useful or necessary.

Control unit remote installation kit / KPCMK

The KPCMK kit is used to remotely control the inverter from the KP500 unit.



Handheld remote control unit

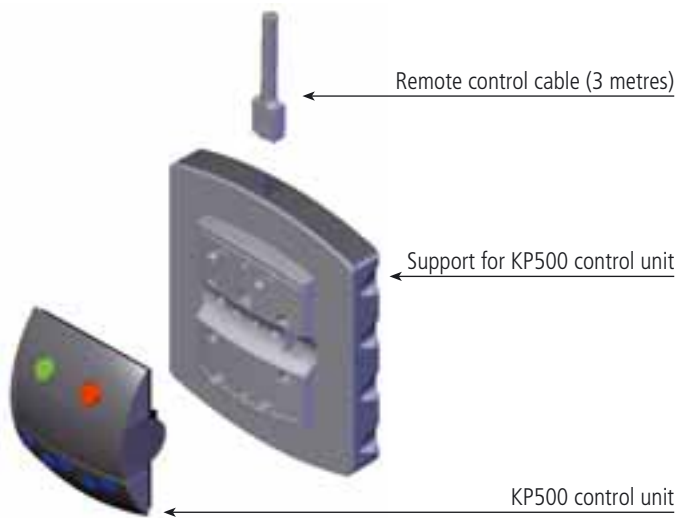

Remote installation on exterior of enclosure

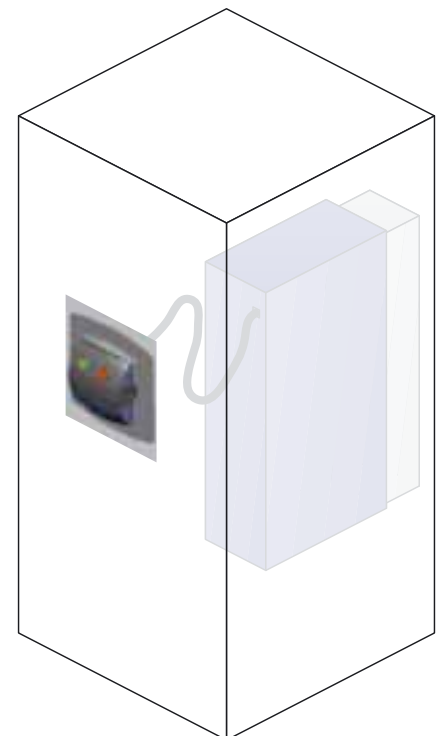

Fixing to enclosure

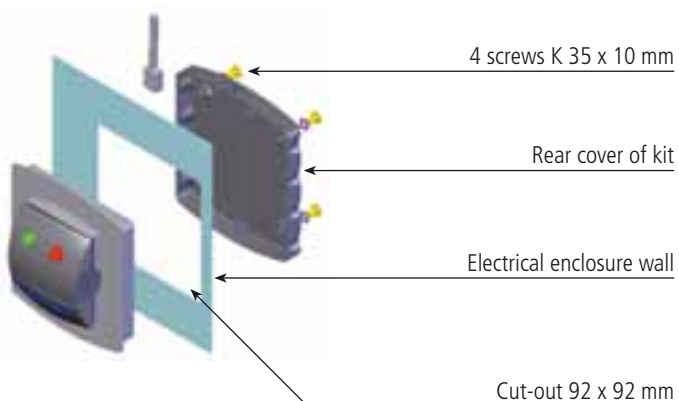

Interface / KP-232



Serial interface KP232 can be used as an alternative to control unit KP500. This connection enables parameterisation, monitoring, setting management, inverter control and even commissioning from a PC or laptop computer. The serial point-to-point connection between inverter and PC complies with specifications for transmission between data terminals (DTE) and data communication equipment (DCE), requiring, in this mode, a serial pin-to-pin cable with DB9 male connector on the inverter side.

The KP232 interface is compatible with lines no longer than 15 metres. The serial transmission protocol ensures high data security and does not require handshake signals between computer and inverter.

The VPlus software application can be supplied as an accessory. This program, which runs in Windows, is dedicated to the complete management of the ACTIVE CUBE inverter from a PC, including the functions of commissioning and parameterisation, which calls for the presence of hardware interface KP232, CM232 or CM485. The VPlus package also includes a digital Oscilloscope Function. The oscilloscope has four traces configurable for inverter monitoring also with graphic capabilities.

Technical data

Baud rate (kBaud)

Up to 115.2 kb

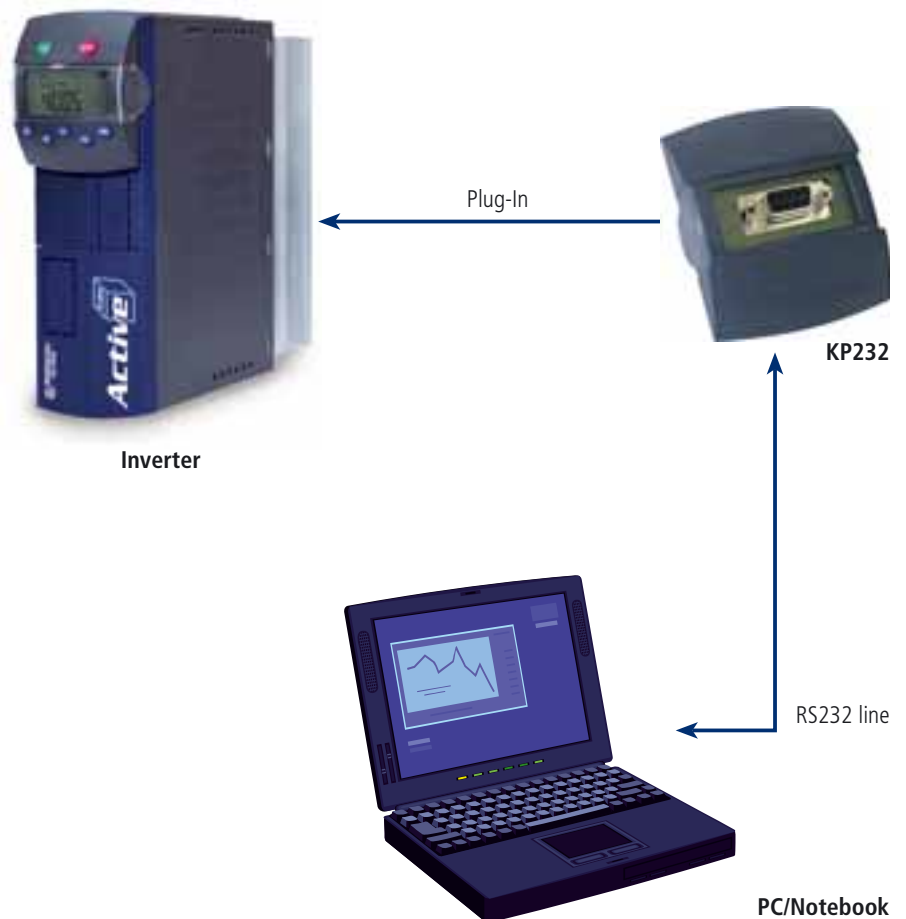

RS232 / CM-232 serial communication

The optional CM-232 communication card enables RS232 serial connection of the ACTIVE inverter to an external control device or PC to ANSI standard EIA/TIA-232E and CCITT V.28. The standard defines the electrical and mechanical characteristics of serial connections between data terminating equipment (DTE) and data communication equipment (DCE).

The serial interface, in the form of a DB9 plug, features DCE type pinouts.

The serial transmission protocol ensures high data security and allows connection, also without handshake signals, thereby reducing the required number of connection lines to just three.

Maximum allowed distance between the various bus nodes (inverters) and the master (PC, PLC) depends on the cable used and the selected transmission rate.

This option can be used as well for inverter programming and monitoring with VPlus software.



Technical data	
Cable lenght	Max Baud rate
up to 30m	19,2 kBaud
up to 10m	115,2 kBaud

Cable length limits the transmission bandwidth. Above table shows the match between admissible cable lengths and corresponding max kBaud rates. Values are indicative and may significantly change in relation to the transmission cable characteristics.

The values given in the table are guideline and are subject to variations in relation to the cable characteristics.

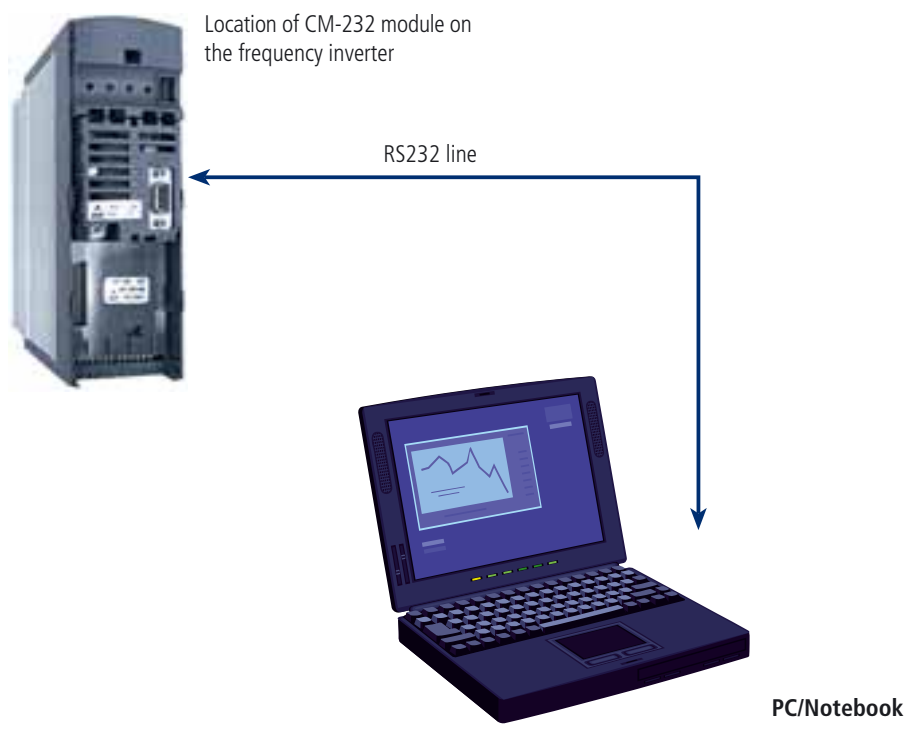

RS485 / CM-485 serial communication



The CM-485 communication module is designed for high speed data transmission over long distances in industrial applications. RS485 bus supports data exchange among 30 nodes in a bidirectional 2-wires system.

The interface is based on a DB9 connector, following the standards for physical transmission of data ITU V.11 and ANSI EIA/TIA-422B

CM-485 communication card includes the end-of-line terminating resistor that can be activated or disconnected by means of an on-board dip switch.

The RS485 network address of the inverter is set by software parameters either via KP500 control unit or by means of PC in serial communication with KP-232. The RS485 complies with ISO standard 1745 for code-bound data transmission. The standard data exchange rate and monitoring functions can be set using VPlus software.



Location of CM-485 module on the frequency inverter

Technical data	
Cable lenght	Max Baud rate
up to 12000m	4,8 kBaud
up to 2000m	19,2 kBaud

Cable length limits the transmission bandwidth. Above table shows the match between admissible cable lengths and corresponding max kBaud rates. Values are indicative and may significantly change in relation to the transmission cable characteristics.

The values given in the table are guideline and are subject to variations in relation to the cable characteristics.

RS485 / CM-485 serial and Modbus communication

Modbus communication

The communication module CM-485 allows the Modbus Communication profile to be used. The communication profile can be changed to Modbus easily with a parameter. Therefore a very inexpensive solution is available to integrate the ACU inverters in a Modbus Communication environment with the standard ACU devices and a standard module.

There are two profiles available. The Modbus RTU profile is well established and known to the experienced Modbus user, which offers quick communication between different devices. Additionally, Modbus ASCII is supported as well, which allows easy set up and diagnosis of the communication between different devices.

The address range allows values between 1 to 247.

Technical data	
Cable lenght	Max Baud rate
up to 12000m	4,8 kBaud
up to 2000m	19,2 kBaud

Cable length limits the transmission bandwidth. Above table shows the match between admissible cable lengths and corresponding max kBaud rates. Values are indicative and may significantly change in relation to the transmission cable characteristics.

The values given in the table are guideline and are subject to variations in relation to the cable characteristics.



Location of CM-485 module on the frequency inverter

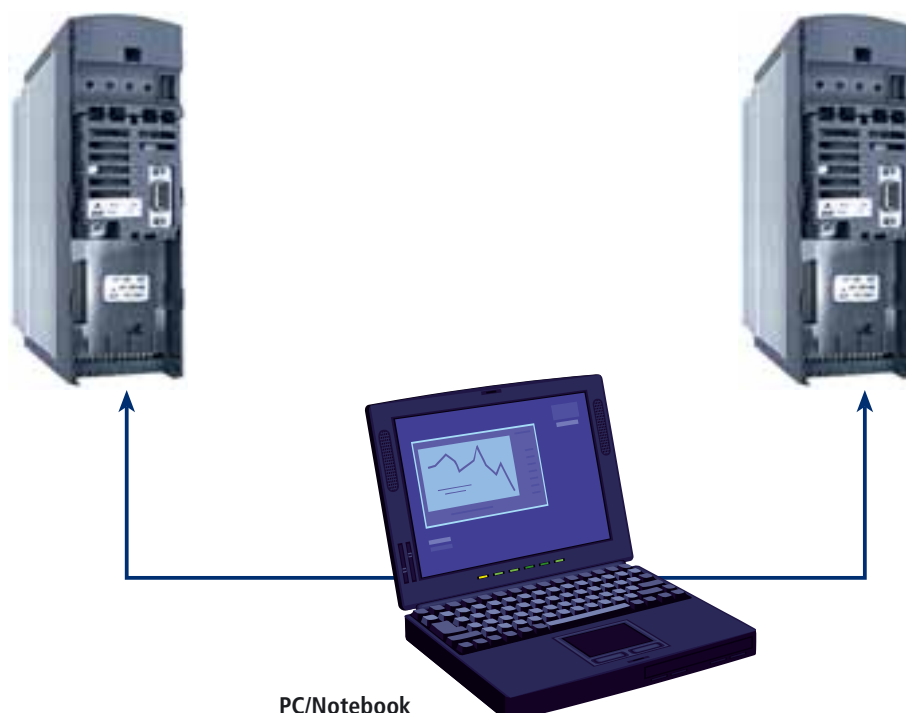

DP / CM-PDPV1 Profibus Communication



Internal dipswitch to enable the 220 Ω terminating burden resistor incorporated in the module



Location of module CM-PDP on the frequency inverter

Profibus DP interface fulfills European fieldbus standard DIN 19245. The Profibus version, which is optimized in order to provide excellent performance in terms of speed and low connection costs, has been adapted for communication between automation systems and decentralized peripheral devices.

Following "variable speed drive" profiles defined by Profidrive for electrical drive technology are supported by CMP-DP: PPO1, PPO2, PPO3, PPO4.

CM-PDP interface supports different transmission rates in compliance with EN 50170 standard. Transmission rate automatically adjusts to the settings of the fieldbus master. CM-PDP module is equipped with a DIP switch for activating end-of-line terminating resistor, included into CM-PDP.

Technical data	
Cable lenght	Max Baud rate
up to 1200m	93,75 kBaud
up to 1000m	187,5 kBaud
up to 400m	500 kBaud
up to 200m	1500 kBaud
up to 100m	12000 kBaud

Cable length limits the transmission bandwidth. Above table shows the match between admissible cable lengths and corresponding max kBaud rates. Values are indicative and may significantly change in relation to the transmission cable characteristics.

The values given in the table are guideline and are subject to variations in relation to the cable characteristics.

CANopen/ CM-CAN communication

The CM-CAN communication option with controller area network interface, complies with ISO/DIS 11898 transmission standard. The pinout of connector DB9 is based on the "CAN in Automation e.V." specification, which allows the connection of up to 127 nodes in the network. The network node addresses are assigned via software. The endburden resistor is activated by means of a DIP switch on the module. The end of line terminating current transmission protocol complies with CANopen specifications DS-301 V4.02. The maximum allowed distance between the bus nodes depends on the cable used and the selected transmission rate. See table.

Technical data	
Cable lenght	Max Baud rate
up to 5000m	10 kBaud
up to 2500m	20 kBaud
up to 1000m	50 kBaud
up to 800m	100 kBaud
up to 500m	125 kBaud
up to 250m	250 kBaud
up to 100m	500 kBaud
up to 25m	1000 kBaud

Cable length limits the transmission bandwidth. Above table shows the match between admissible cable lengths and corresponding max kBaud rates. Values are indicative and may significantly change in relation to the transmission cable characteristics.

The values given in the table are guideline and are subject to variations in relation to the cable characteristics.



Internal dipswitch to enable the terminating resistor incorporated in the module



Location of CM-CAN module on the frequency inverter

System bus / EM-SYS module



Location of EM-SYS module on the frequency inverter

The "System Bus" of ACU inverters is a proprietary communication bus, based on CANopen protocol that allows fast exchange of data between the inverters and access, by a system bus master, to the parameters of all devices connected on the network.

The system bus nodes (max. 64) are connected by a two-wire line.

The Bus termination (at either first or last node) can be activated via DIP switches of the EM-SYS module.

The system bus is equipped with three PDO (Process Data Object) channels that allow rapid exchanges of process data for each inverter. There are also two SDO (Service Data Object) channels for parameterisation purposes.

Thanks to the three PDO channels with one transmission and one reception channel, all inverter data can be transmitted. Among other advantages, this makes it possible to create master/slave and daisy chain configurations easily, while ensuring very high precision and speed.

Each transmission and reception channel includes 8 bytes that can be freely occupied by objects, thereby offering the maximum flexibility for a very broad range of applications. The selection of transmission objects and reception objects is made easy by the VPlus program, and no additional configuration tools are needed.

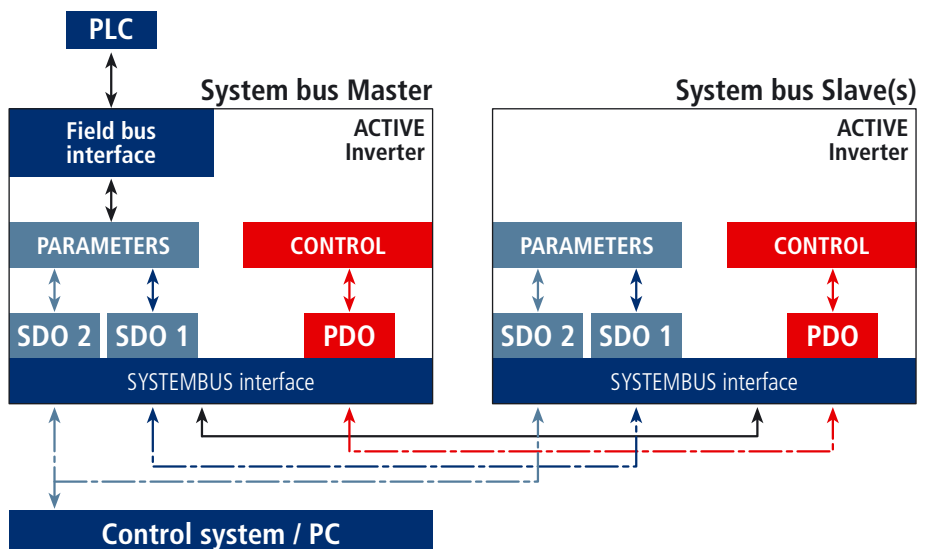

Input-output module / EM-IO-01

The EM-IO-01 expansion module extends the number of the standard inputs and outputs provided on the ACT inverter for connection of various applications. Analog inputs and outputs can be available also with bipolar signals and must therefore be configured with inverter parameters.

The supplementary digital inputs provided on the expansion module are electrically equivalent to the standard inputs. The relay changer contact represents an alternative for the activation of high power to the relay output available as a standard feature. SYSTEMBUS is available on two control terminals and supports easy control of decentralised drive systems.

The module is equipped with a removable terminal board divided into two parts (X410A and X410B) that are physically separated.



Location of EM-IO-01 module on the frequency inverter

Terminal board layout and functions:

Terminal	Function
X410A.1	20 VDC power supply output (180 mA)
X410A.2	20 V power supply GND
X410A.3	EM-S1IND multifunction digital input $V_{max} = 30\text{ V}$ (24 V/10 mA), PLC compatible
X410A.4	EM-S2IND multifunction digital input $V_{max} = 30\text{ V}$ (24 V/10 mA), PLC compatible
X410A.5	EM-S3IND multifunction digital input $V_{max} = 30\text{ V}$ (24 V/10 mA), PLC compatible
X410A.6	EM-S1OUTD multifunction relay output, $U_{max} = 24\text{ V}$, 1 A (ohmic)
X410A.7	

Terminal	Function
X410B.1	EM-S2OUTD multifunction relay output, $U_{max} = 24\text{ V}$, 1 A (ohmic)
X410B.2	
X410B.3	EM-S1INA +/- 10 V and +/- 20 mA analog input
X410B.4	EM-S1OUTA +/- 10 V multifunction analog output
X410B.5	CAN-Low Systembus
X410B.6	CAN-High Systembus
X410B.7	GND for +/- 10 V signals

Terminal board X410A

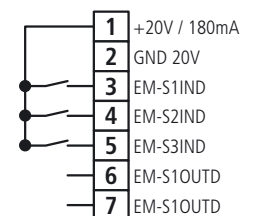

Terminal board X410B

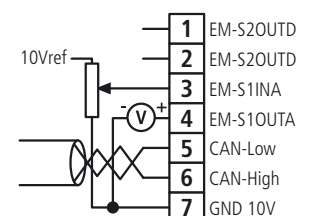

Input-output module / EM-IO-02



Location of EM-IO-02 module on the frequency inverter

Like EM-IO-01, the EM-IO-02 expansion module extends the standard inputs and outputs featured on ACT frequency inverters.

The EM-IO-02 module has a slightly modified layout compared to the -01 version, featuring an input for a PTC thermal probe in place of one of the module relay outputs. The functions of all the other terminals are same as in EM-IO-01.

Terminal board layout and functions:

Terminal board X410A

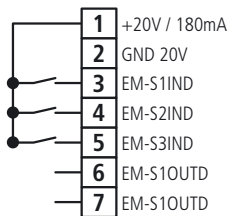

Terminal	Function
X410A.1	20 V power supply output (180 mA)
X410A.2	20 V power supply GND
X410A.3	EM-S1IND multifunction digital input $V_{max} = 30\text{ V}$ (24 V/10 mA), PLC compatible
X410A.4	EM-S2IND multifunction digital input $V_{max} = 30\text{ V}$ (24 V/10 mA), PLC compatible
X410A.5	EM-S3IND multifunction digital input $V_{max} = 30\text{ V}$ (24 V/10 mA), PLC compatible
X410A.6	EM-S1OUTD multifunction relay output, $U_{max} = 24\text{ V}$, 1 A (ohmic)
X410A.7	

Terminal board X410B

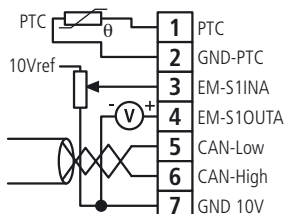

Terminal	Function
X410B.1	Input for motor PTC
X410B.2	GND for motor PTC
X410B.3	EM-S1INA +/- 10 V and +/- 20 mA analog input
X410B.4	EM-S1OUTA +/- 10 V multifunction analog output
X410B.5	CAN-Low Systembus
X410B.6	CAN-High Systembus
X410B.7	GND for +/- 10 V signals

Input-output module / EM-IO-03

The EM-IO-03 expansion module is another variant for the extension of I/O facilities of ACTIVE frequency inverters.



Location of EM-IO-03 module on the frequency inverter

Terminal board layout and functions:

Terminal	Function
X410A.1	20 V DC power supply output (180 mA)
X410A.2	20 V power supply GND
X410A.3	EM-S2OUTA multifunction analog output 0-20 V / 4-20 mA
X410A.4	EM-S2IND multifunction digital input $V_{max} = 30\text{ V}$ (24 V/10 mA), PLC compatible
X410A.5	EM-S3IND multifunction digital input $V_{max} = 30\text{ V}$ (24 V/10mA), PLC compatible
X410A.6	EM-S1OUTD multifunction relay output, $U_{max} = 24\text{ V}$, 1 A (ohmic)
X410A.7	

Terminal board X410A

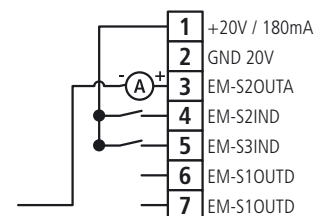

Terminal	Function
X410B.1	Input for motor PTC
X410B.2	GND for motor PTC
X410B.3	EM-S1INA +/- 10 V and +/- 20 mA analog input
X410B.4	EM-S1OUTA +/- 10 V multifunction analog output
X410B.5	CAN-Low Systembus
X410B.6	CAN-High Systembus
X410B.7	GND

Terminal board X410B

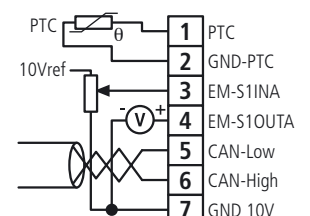

Input-output module / EM-IO-04



The EM-IO-04 expansion module is another variant for the extension of I/O facilities of ACTIVE frequency inverters.



Location of EM-IO-04 module on the frequency inverter

Terminal board layout and functions:

Terminal board X410A

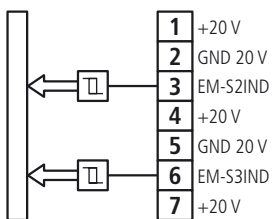

Terminal	Function
X410A.1	Voltage output 20 V
X410A.2	Earth / GND 20 V
X410A.3	Digital input EM-S2IND
X410A.4	Voltage output 20 V
X410A.5	Earth / GND 20 V
X410A.6	Digital input EM-S3IND
X410A.7	Voltage output 20 V

Terminal board X410B

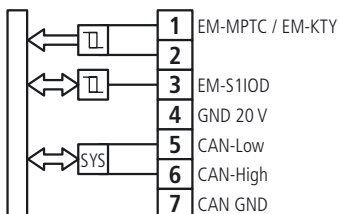

Terminal	Function
X410B.1	Motor PTC thermistor connection EM-MPTC or connection motor temperature sensor EM-KTY
X410B.2	
X410B.3	Digital Port EM-S1IOD / Digital input or digital output
X410B.4	Earth / GND 20 V
X410B.5	CAN-Low Systembus
X410B.6	CAN-High Systembus
X410B.7	Earth / GND

Speed sensor module / EM-ENC-01

The EM-ENC-01 expansion module extends the number of speed sensor inputs of terminal board of the frequency inverter, and also increases the number of configurable pulse outputs with encoder repetition output with encoder repetition output.

EM-ENC-01 is able to acquire both TTL and HTL incremental speed sensors according to standard EIA RS422 (line driver) with 5-volt logic. The EM-ENC-01 speed sensor module is equipped with connection terminals for signals A, \bar{A} , B and \bar{B} of the line driver speed sensor and terminals for repetition output of the same signals (speed sensor emulation). This makes it possible to create master-slave configurations between several separate units using output signals of one unit as input signals of the next.

The DC +/- 10 V analog input can be used for the inverter frequency reference signal. The same terminal board also provides a DC + 5 V (200 mA) power supply for the line driver speed sensor.

As other EM expansion modules, the EM-ENC-01 features a Systembus interface.



Location of EM-ENC-01 module on the frequency inverter

Terminal board layout and functions:

Terminal	Function
X410A.1	Channel A speed sensor input
X410A.2	Channel \bar{A} speed sensor input
X410A.3	Channel B speed sensor input
X410A.4	Channel \bar{B} speed sensor input
X410A.5	+ 5 V (200 mA) power supply output
X410A.6	5 V power supply GND
X410A.7	Speed sensor channel A repetition output

Terminal	Function
X410B.1	Channel \bar{A} speed sensor repetition output
X410B.2	Channel B speed sensor repetition output
X410B.3	Channel \bar{B} speed sensor repetition output
X410B.4	EM-S1INA +/- 10 V analog input
X410B.5	CAN-Low Systembus
X410B.6	CAN-High Systembus
X410B.7	GND

Terminal board X410A

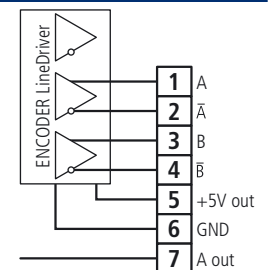

Terminal board X410B

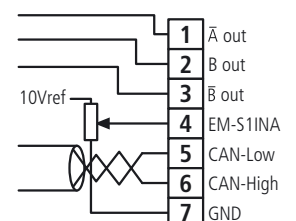

Speed sensor module / EM-ENC-02



Location of EM-ENC-02 module on the frequency inverter

The EM-ENC-02 speed sensor module extends the standard terminal board of the inverter, providing an interface for line driver encoders with relative DC + 5 V power supply.

The same module is equipped also with a DC 0 ... 20 mA and +/- 20 mA analog input and a DC + 20 mA analog output, together with an input for a PTC thermal probe and a digital port configurable as an input or output.

Also this module is equipped with a Systembus port.

Terminal board layout and functions:

Terminal board X410A

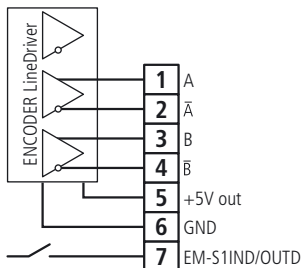

Terminal	Function
X410A.1	Channel A speed sensor input
X410A.2	Channel \bar{A} speed sensor input
X410A.3	Channel B speed sensor input
X410A.4	Channel \bar{B} speed sensor input
X410A.5	+ 5 V (200 mA) power supply output
X410A.6	5V power supply GND
X410A.7	EM-S1IND/OUTD digital input/output

Terminal board X410B

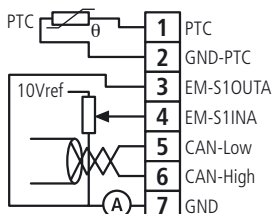

Terminal	Function
X410B.1	Input for motor PTC
X410B.2	GND for motor PTC
X410B.3	EM-S1OUTA 0 ... 20 mA analog output
X410B.4	EM-S1INA +/- 10 V and +/- 20 mA analog input
X410B.5	CAN-Low Systembus
X410B.6	CAN-High Systembus
X410B.7	GND

Speed sensor module / EM-ENC-03

The EM-ENC-03 extends the standard terminal board of the inverter, providing an interface for line driver speed sensors. Also this module is equipped with a Systembus port.



Location of EM-ENC-03 module on the frequency inverter

Terminal board layout and functions:

Terminal	Function
X410A.1	Channel A speed sensor input
X410A.2	Channel \bar{A} speed sensor input
X410A.3	Channel B speed sensor input
X410A.4	Channel \bar{B} speed sensor input
X410A.5	-
X410A.6	GND
X410A.7	-

Terminal board X410A

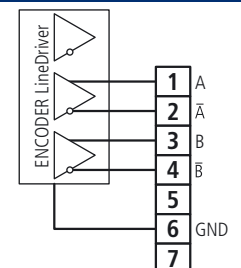

Terminal	Function
X410B.1	-
X410B.2	-
X410B.3	-
X410B.4	-
X410B.5	CAN-Low Systembus
X410B.6	CAN-High Systembus
X410B.7	GND

Terminal board X410B

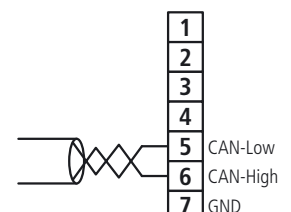

Speed sensor module / EM-ENC-04



Location of EM-ENC-04 module on the frequency inverter

The EM-ENC-04 speed sensor module extends the standard terminal board of the inverter, providing an interface for line driver speed sensors with Z channel. This module is able to manage TTL, HTL, or push-pull incremental speed sensors to standard EIA RS422 (line driver). The EM-ENC-04 speed encoder module is equipped with 6 control terminals for A, \bar{A} , B, \bar{B} direction signals and Z and \bar{Z} zero signals transmitted by the speed sensor. The same module also features a ± 10 V and ± 20 mA analog input and a ± 10 V voltage output in addition to a digital relay output. The module also features two output voltages (+ 5 V and + 24 V) for the speed sensor power supply.

Terminal board layout and functions:

Terminal board X410A

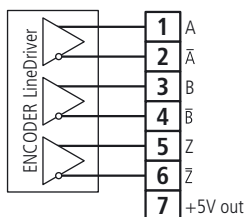

Terminal	Function
X410A.1	Channel A speed sensor input
X410A.2	Channel \bar{A} speed sensor input
X410A.3	Channel B speed sensor input
X410A.4	Channel \bar{B} speed sensor input
X410A.5	Channel Z speed sensor input
X410A.6	Channel \bar{Z} speed sensor input
X410A.7	+ 5 V power supply output (200mA)

Terminal board X410B

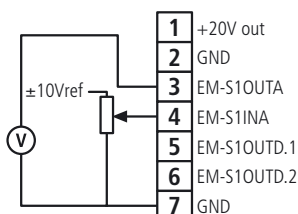

Terminal	Function
X410B.1	+ 20 V power supply output (180 mA)
X410B.2	Power supply GND
X410B.3	± 10 V analog output
X410B.4	± 10 V analog input
X410B.5	EM-S10UTD multifunction relay output, $U_{max} = 24$ V, 1 A (ohmic)
X410B.6	
X410B.7	GND

Speed sensor module / EM-ENC-05

The EM-ENC-05 speed sensor module extends the standard terminal board of the inverter, providing an interface for line driver speed sensors with Z channel. This module is able to manage TTL, HTL, or push-pull incremental speed sensors to standard EIA RS422 (line driver). The EM-ENC05 speed encoder module is equipped with 6 control terminals for A, \bar{A} , B, \bar{B} direction signals and Z and \bar{Z} zero signals transmitted by the speed sensor. The same module also features a ± 10 V and ± 20 mA analog input and a ± 10 V voltage output in addition to a digital relay output. It is also equipped with a SYSTEMBUS communication bus.



Location of EM-ENC-05 module on the frequency inverter

Terminal board layout and functions:

Terminal	Function
X410A.1	Channel A speed sensor input
X410A.2	Channel \bar{A} speed sensor input
X410A.3	Channel B speed sensor input
X410A.4	Channel \bar{B} speed sensor input
X410A.5	Channel Z speed sensor input
X410A.6	Channel \bar{Z} speed sensor input
X410A.7	+ 5 V power supply output (200mA)

Terminal board X410A

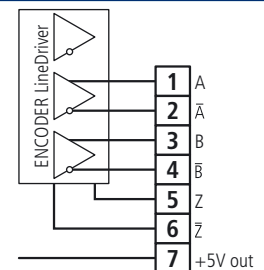

Terminal	Function
X410B.1	+ 20 V power supply output (180 mA)
X410B.2	Power supply GND
X410B.3	EM-S1OUTATA 0 ... 20 mA analog output
X410B.4	EM-S1INA +/- 10 V and +/- 20 mA analog input
X410B.5	CAN-Low Systembus
X410B.6	CAN-High Systembus
X410B.7	GND

Terminal board X410B

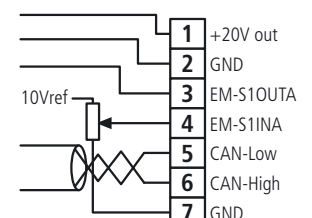

Resolver Module / EM-RES-01



Location of EM-RES-01 module on the frequency inverter

The EM-RES-01 angular position transducer module extends the standard functions of the frequency inverter by providing a supplementary input for a resolver (electromechanical absolute speed sensor).

Resolver gives the instantaneous motor shaft position value even at standstill, and its angular position within a revolution.

EM-RES-01 provides 6 terminals for connection of the two $\sin\theta$ and $\cos\theta$ track signals generated by the transducer and also carry the resolver power supply voltage.

The module EM-RES-01 also supplies an output signal emulating a digital incremental speed sensor through the generation of squarewave signals A, \bar{A} , B, \bar{B} , which can be used for shaft synchronisation of any connected slave inverters.

The EM-S11INA multifunction analog input (± 10 V or ± 20 mA) extends the standard functions of the ACT frequency inverter.

Terminal board layout and functions:

Terminal board X410A

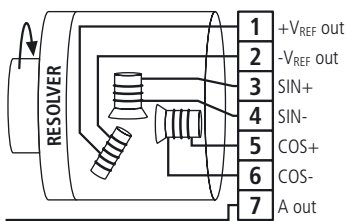

Terminal	Function
X410A.1	(+) ~6 VAC resolver power supply
X410A.2	(-) (I _{max} = 60mA)
X410A.3	Resolver $\sin\theta$ signal input
X410A.4	
X410A.5	Resolver $\cos\theta$ signal input
X410A.6	
X410A.7	Channel A speed sensor emulation

Terminal board X410B

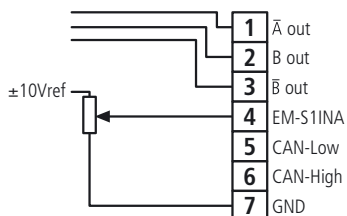

Terminal	Function
X410B.1	Channel \bar{A} speed sensor emulation
X410B.2	Channel B speed sensor emulation
X410B.3	Channel \bar{B} speed sensor emulation
X410B.4	± 10 V or ± 20 mA analog input
X410B.5	CAN-Low Systembus
X410B.6	CAN-High Systembus
X410B.7	GND

Resolver Module / EM-RES-02

EM-RES-02 angular position transducer module extends the standard functions of the frequency inverter by providing a supplementary input for a resolver. This module shares all the features of EM-RES-01 except for the emulation of the encoder zero signal, which in this case is replaced by a Systembus port.



Location of EM-RES-02 module on the frequency inverter

Terminal board layout and functions:

Terminal	Function
X410A.1	(+) ~6 VAC resolver power supply
X410A.2	(-) ($I_{max} = 60mA$)
X410A.3	Resolver $\text{sen}\theta$ signal input
X410A.4	
X410A.5	Resolver $\text{cos}\theta$ signal input
X410A.6	
X410A.7	Channel A speed sensor emulation

Terminal	Function
X410B.1	Channel \bar{A} speed sensor emulation
X410B.2	Channel B speed sensor emulation
X410B.3	Channel \bar{B} speed sensor emulation
X410B.4	$\pm 10\text{ V}$ or $\pm 20\text{ mA}$ analog input
X410B.5	Channel Z speed sensor emulation
X410B.6	Channel \bar{Z} speed sensor emulation
X410B.7	GND

Terminal board X410A

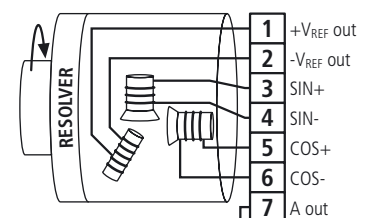

Terminal board X410B

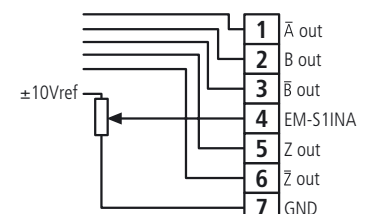

Resolver Module / EM-RES-03



EM-RES-03 resolver module extends the standard functions of Active Cube servo inverter providing a supplementary input for resolver.

It is designed specifically for BTD/BCR synchronous servomotors resolver feedback acquisition. EM-RES-03 is equipped with DB9 connector, that allows fast and easy connection to Bonfiglioli synchronous servomotors, when using BTD/BCR power and control cables.

As essential component of Bonfiglioli servo package, EM-RES-03 module can be used only in Active Cube.



Location of EM-RES-03 module on the frequency inverter

Resolver- and PTC input (SubD-9)	Pin	Designation	Function
	Socket	Shielding	Connected with PE
	1	PE	Protective earth conductor
	2	PTC+	PTC thermistor connection
	3	COS+	Cosinus track
	4	SIN+	Sinus track
	5	+UE	Excitation voltage
	6	PTC-	PTC thermistor connection
	7	COS-	Cosinus track
	8	SIN-	Sinus track
9	-UE	Excitation voltage	

Terminal board layout and functions:

Terminal board X410A

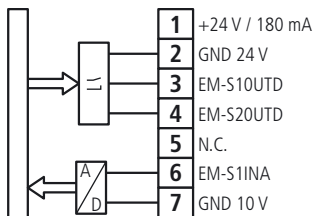

Terminal	Function
X410B.1	DC-24 V output (max. 180 mA)
X410B.2	Ground 24 v
X410B.3	Digital output EM-S10UTD
X410B.4	Digital output EM-S20UTD
X410B.5	Not connected
X410B.6	Analog input EM-S11NA
X410B.7	Ground 10 V

Terminal board X410B

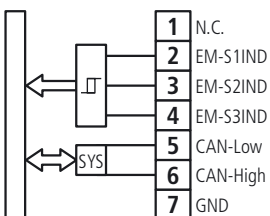

Terminal	Function
X410B.1	Not connected
X410B.2	Digital input EM-S11IND
X410B.3	Digital input EM-S2IND
X410B.4	Digital input EM-S3IND
X410B.5	System bus, CAN-Low
X410B.6	System bus, CAN-High
X410B.7	Ground

VPlus is a PC Windows-based engineering software tool that guides industrial automation designers through the steps towards the definition of the optimal configuration of Active Cube drives.

Communication between VPlus and the drive is based on standard serial communication either through KP232, CM232 or CM-485 interface.

With VPlus a wide set of activities on Active Cube are possible:

Monitoring

Advanced display tools, help to have correct information about drive operation and process variables.

"Actual values" windows collect all variables of interest in one screenshot and displays the real time value of them (variables can be selected by user).

VPlus "dashboards" display real time values of selected variables with an effective visual tool.

Diagnosis

VPlus includes a reliable integrated oscilloscope monitor, able to provide real time traces of main device parameters and process selected variables. That distinctive feature is very useful both during normal operation and in case of exceptional events to collect comprehensive detailed information about drive behaviour, helping both analysis and troubleshooting. Commissioning your machine is easy with Oscilloscope monitor.

Inverter set up and parameter access

The drive setup up is really easy. Important functions like the motor set-up allow you to configure your system in short time. With the parameter tree design, all parameters are sorted logically by the functions and can be accessed intuitively.

Software customization

Drive software customization is possible having access to inner parameter levels and using PLC logic programming to create new drive control routines.

Technology functions management

High level technology functions of the drive, as well as specific application functions can be accessed and activated.

For example, VPlus software includes a section dedicated to setup and link of Motion Blocks for positioning applications, and a section for logic PLC functions management. Also application customized functions are available, such as dynamic brake release control, spindle motor control, multipump management, and others.

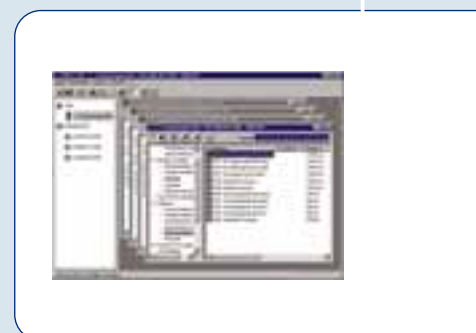
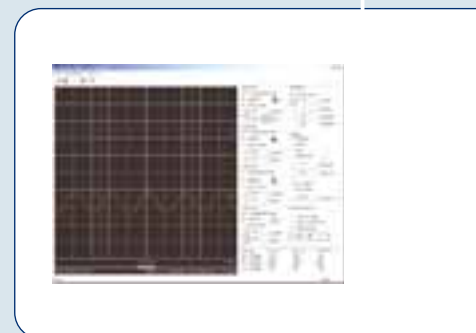



Motor setup

A wide set of functionalities are available to get to faster and more effective motor "recognition".

A dedicated window for induction motor rated values load is available, and new parameters can be freely selected and added to rearrange the default window.

The accurate autotuning procedure of Active Cube, used to optimize motor control, can be started via software, through a simple flag change.

The parameter values for Bonfiglioli synchronous servomotor control are available in the drive: rated speed, stall torque, load curves, resolver phase angle, etc. for all existing Bonfiglioli servomotors ratings are stored into the standard device.

Selection and load of correct values for the servomotor is done directly by the drive after the motor designation is selected through an easy guided interface: the procedure takes only few seconds and no further autotuning is required to have the motor running correctly.

Commissioning

VPlus engineering software is very powerful tool in commissioning and machine start up phases, both in case Active Cube is used as a "system drive" and as "servo drive".

Usual adjustments to last minute requests and system troubleshooting needed, take benefit of the extreme flexibility and handy set of tools that engineers can find in VPlus to support "on site" activities

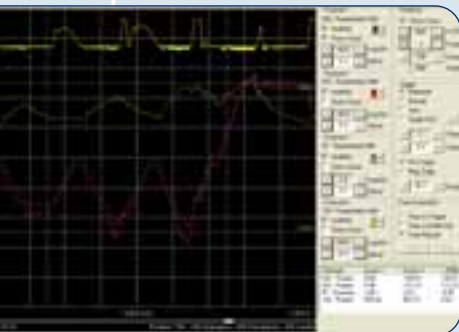

ACTIVE CUBE oscilloscope graphic presentation

The functionality and practicality of the virtual oscilloscope are identical to those of a powerful and modern conventional oscilloscope, with the added benefit that all the parameters controlled by the inverter microprocessor can be displayed, whether of a physical nature (current, voltage, frequency, etc.) or a virtual nature (internal control variables, timer signals, comparator signals, internal digital signals, etc.).

Salient features of the Oscilloscope Function:

- 4 channels
- Display of absolute values
- Amplitude and time measurement cursors
- Timebase from 20 ms/div to 50 s/div
- Various trigger types
- Graphic memory up to 1 Mbyte
- Trace recording memory up to 60 min.
- Sampling times from 2 ms to 32 ms (depending on the PC)
- Various trace storage formats

Active Cube control levels

Active Cube has by far the widest application potential of all Bonfiglioli drive offer, thanks to its extremely rich set of functionalities, combined with flexible hardware structure and significant power range extension.

3 "virtual" functional levels can be defined, related to different control "areas":

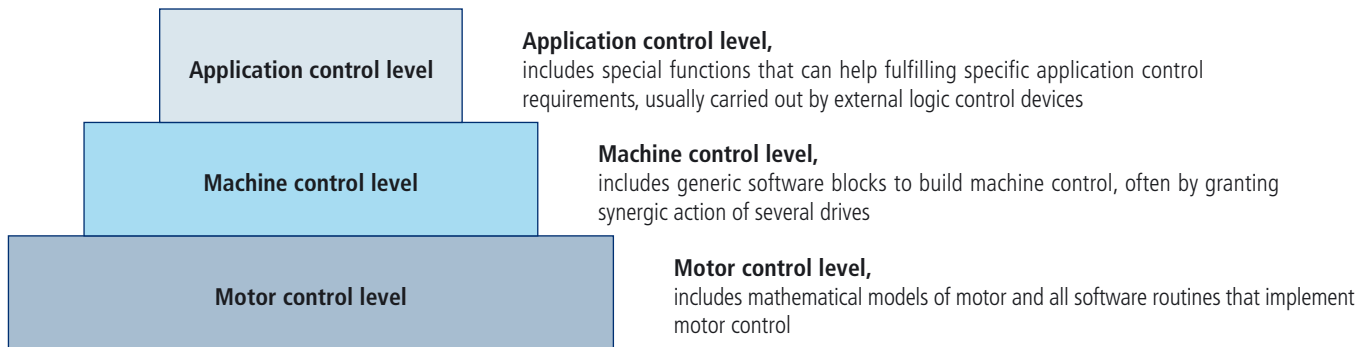

Motor control level

At Motor control level, Active Cube is designed to suite to almost all motor technologies used in industrial machines: synchronous servomotors, rotating or linear motors, as well as traditional asynchronous induction motors can be used with standard Active Cube devices..

Many available different control modes, provide the possibility to select the right mix of accuracy, ease, stability of performance to satisfy the requirements of any industrial applications, from fan and pump control, to sophisticated positioning or synchronization systems.

Motor control modes	<p>Simple Sensorless Control of induction motors (mode 110) Accuracy: ● Ease of use: ●●●●</p> <p>Closed loop Field Oriented (Vector) control of induction motors (mode 210) Accuracy: ●●●● Ease of use: ●●</p> <p>Sensorless Field Oriented (Vector) control of induction motors (mode 410) Accuracy: ●●● Ease of use: ●●●</p> <p>Closed loop Field Oriented (Vector) control of synchronous servomotors (mode 515) Accuracy: ●●●● Ease of use: ●●●●</p>
----------------------------	--

Machine control level

Within each Motor control mode, a range of “machine” control functions, belonging to Machine control level, is available. These functions aim to give to users and designers of Active Cube a set of ready-to-use routines and functions able to fit, with few adjustments, the automation needs of many different machines and sectors: PID function, Master/Slave synchronization, electronic shaft/gear, torque/speed switching, and position control functions are only few examples.

Control Mode		Control Function					
		PID (x11)	Master slave and electronic gear (x15)	Torque/speed switching (x30)	Index control (x16)	Brake control and load detection (x60)	Position control (x40)
Simple sensorless for induction motors	110	X	X		X	X	
Closed loop field oriented of induction motors	210		X	X	X	X	X
Sensorless field oriented of induction motors	410	X	X	X		X	X
Closed loop field oriented of synchronous servomotors	510		X	X	X	X	X

Application control level

Third level “Application (specific) control level” includes particular features and control routines designed to match the requirements of unusual industrial applications.

These functions are giving to Active Cube exceptional ability to fulfil non-common needs of such applications: no necessity of customized versions of the drive, because software functions are stored in standard Active Cube devices and can be activated directly by customer.

Examples are: spindle control up to 1000Hz (machining), extended brake control with load detection (lifting), synchronized “traverse” function (yarn winders), motion blocks management.

Please find more details about these functions in product documentation or to your local DSC.

Safe torque off (STO)

The safety function "Safe Torque Off" (STO) with the safety integrity level SIL 2 (see DIN EN 61508 and DIN IEC 61800-5-2) is implemented into standard Active Cube inverter range.

The drive feature helps overall automation system to achieve "Safe Stop" category 3, according to DIN EN 954-1.

Thanks to STO function, energy supply from frequency inverter to motor is safely disabled. Deactivation of the inverter supply is carried out via two switch off paths in no-signal current mode, thus performing redundant switch off control.

Continuous monitoring tests are done by the inverter to detect possible control failures. "Safe Torque Off" function greatly improves safety level of your automation system without the need of additional components.

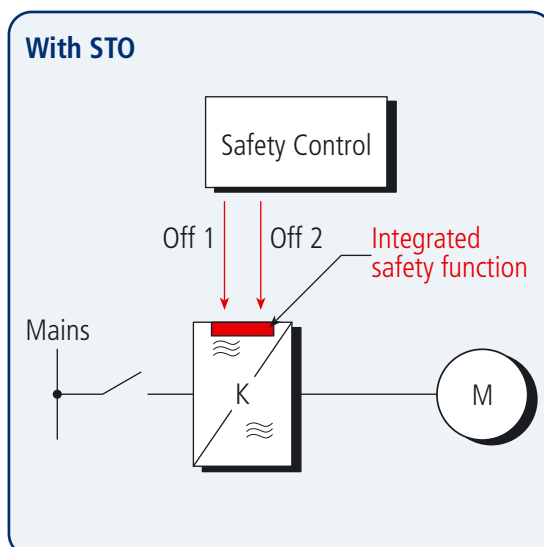
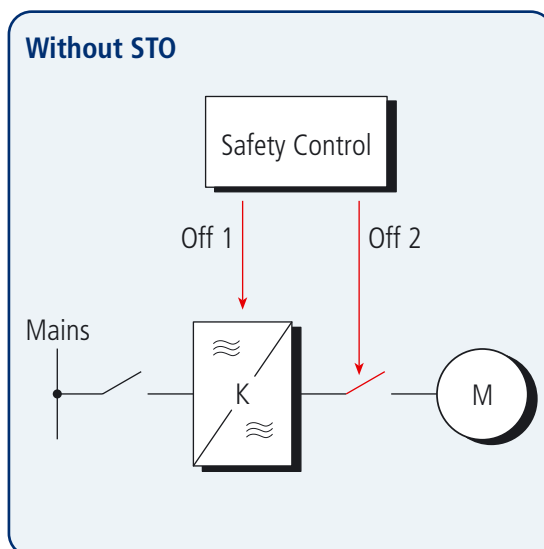

Logic functions

Standard Active Cube is equipped with integrated "PLC like" logic functions to exploit at best automation ability of the drive. Onboard control logic functions are based on a runtime software able to execute a "block operation" every 1msec.

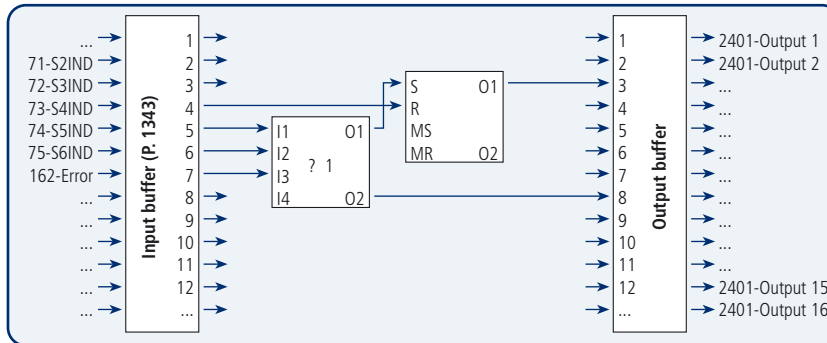

Sophisticated control routines design is within range with new logic functions. Software developers will be able to adjust drive controls fitting automation requirements, simply combining the 16 inputs with the 32 function blocks available and achieving results in the 16 output latches.

Following features are implemented:

Input buffer for up to 16 signals

e.g. for

- Digitals inputs
- Errors
- Warnings
- RxPDO booleans of systembus

Output buffer for up to 16 signals

e.g. for

- Start clockwise / anticlockwise
- Data set change - over
- Digital outputs
- TxPDO booleans of systembus
- ...

32 functions configurable as

- Logic functions:
 - AND
 - OR
 - XOR
- Flip-flops:
 - RS-flip-flop
 - Toggle-flip-flop
 - D-flip-flop
- Timer-functions:
 - Delay for rising/falling edge
 - Mono-flop
 - Oscillator
- Additional functions:
 - Multiplexer for digital signals
 - Conditional jumps

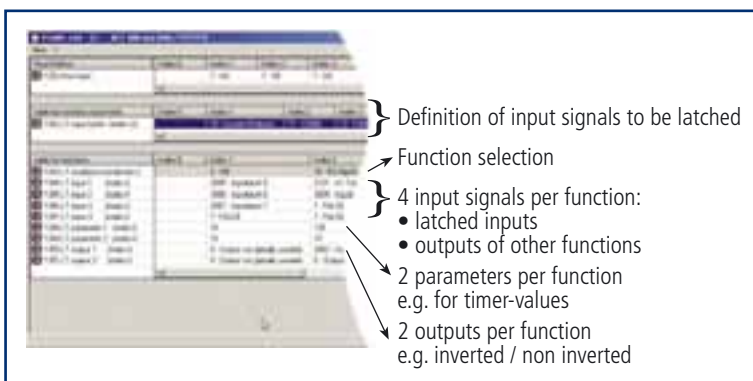

Setting logic functions is easier than ever, thanks to VPlus dedicated configuration section.

Parameters needed for logic functions are collected together in a single view/window for better and easier programming.

For detailed information about advanced programming features, please refer to your nearest Bonfiglioli Drive Service Centre, where experts are available for customer technical support.

Motion blocks

The “elemental software unit” of motion control in Active Cube is the “Motion Block”. One “Motion Block” completely outlines one point-to-point positioning step, including:

- target position,
- speed,
- acceleration,
- deceleration,
- ramps,
- delays

Built-in motion control functions allow to combine up to 32 motion blocks in a conditional sequence, to program even most sophisticated point-to-point motion profiles

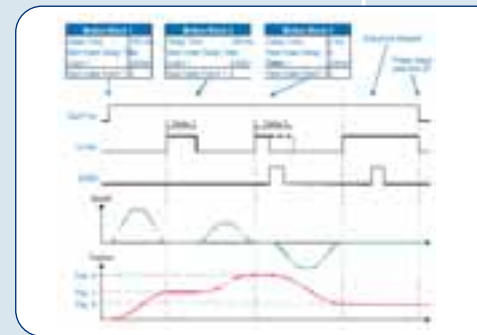
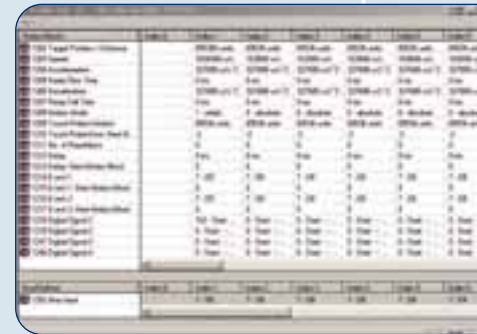

Homing

A comprehensive set of homing functions, according to CANOpen DSP 4.02 standard is available in Active Cube. 36 different homing modes can be used to answer to the motion requirements of a wide range of machines.

Homing search can be triggered by either digital input (e.g. hardware limit switches), or control word (if Fieldbus is used), or as an automatic procedure before first positioning sequence.

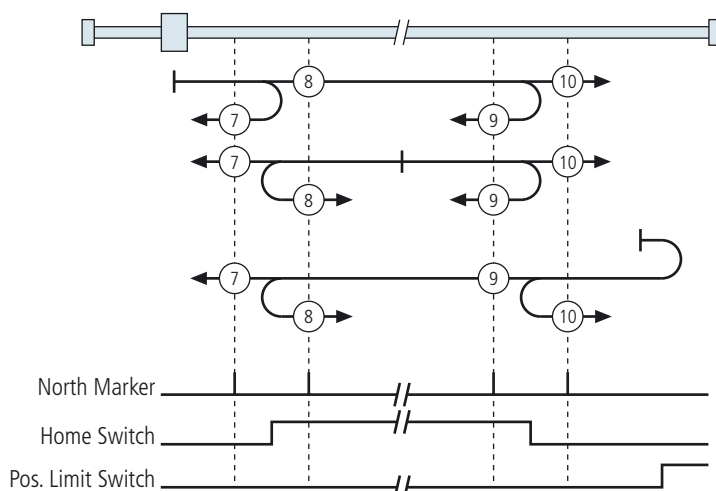

Rotary table function

When controlling a rotary working table target position is calculated and reached within one revolution. Rotary table function enables the drive to detect the shortest way to reach the desired angular position, considering the shaft revolutions needed to do a complete table rotation.

Best sense of rotation, clockwise or anti-clockwise can also be detected, in order to minimize travel time and distance.

Jog and teach-in functions



In "jog mode" drive can be freely moved at fixed speed in both directions through the "manual" set of assigned digital inputs.

During jog mode, several target positions can be approached and saved through Teach-in function: when desired position is reached, teach-in function allows to take over actual position in the active travel record as target position.

Introduction

When using Active Cube in servo applications, you can get the best out of the drive when applied together with Bonfiglioli servomotors.

Active Cube and Bonfiglioli servomotors were, in fact, designed to exploit at best reciprocal synergies thus forming a servo "package", able to provide significant advantages to users both in terms of enhanced performance and in terms of reduced setup time.

The Bonfiglioli servo system benefits from several specific solutions, involving the 2 product series:

- Active Cube has a preloaded parameter profile of Bonfiglioli servomotors.
- Wiring the drive to motor is easier thanks to the availability of factory pre-wired cables and connectors.
- "Motion" functions are readily available

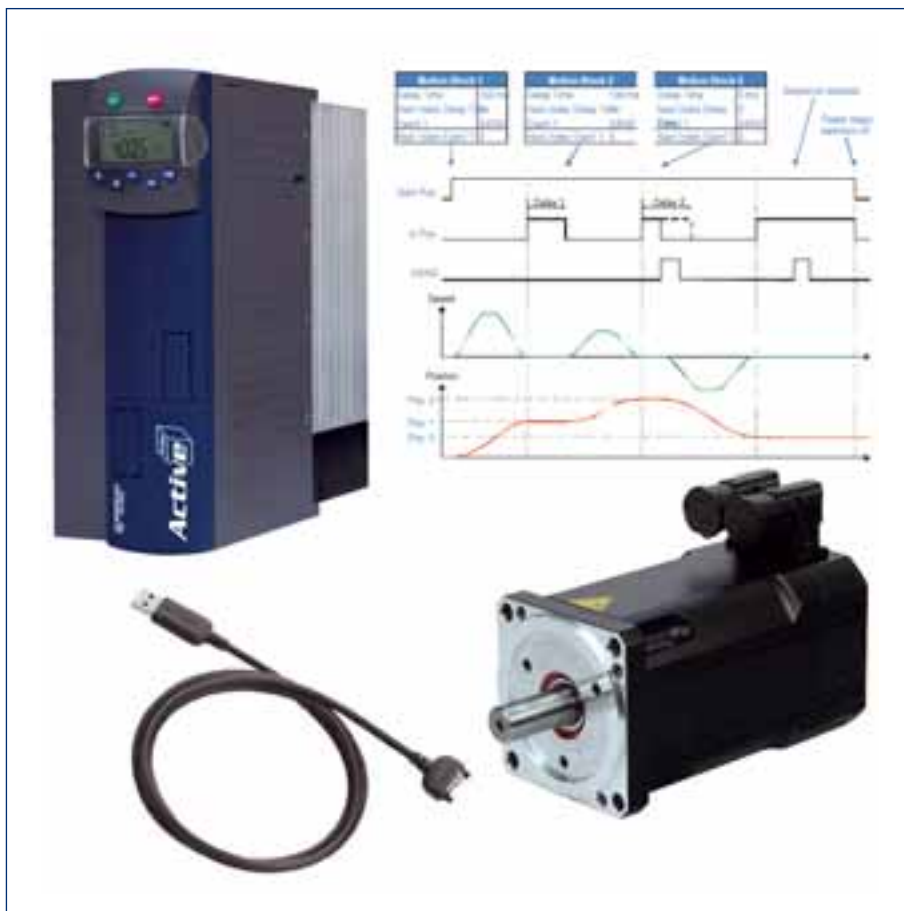

Bonfiglioli servomotors range



Bonfiglioli servomotors offer includes 2 series of permanent magnet synchronous servomotors, **BTD** (Bonfiglioli Torque Density) and **BCR** (Bonfiglioli Classic Range) featured by different speed and torque ranges, achieved through different construction technologies.

BTD and BCR series are split into many frame sizes, each of them grouping together devices with same flange dimensions and different motor lengths able to supply different torque ratings within one frame size

BCR devices are designed to provide a wide rated torque range up to 115 Nm and peak torque up to 400%.

BTD devices, fulfil the need of high torque in small motor dimensions. Innovative construction technology, together with high quality of magnets used allows BTD servomotors achieving a "torque density of 15,3 Nm/dm³.

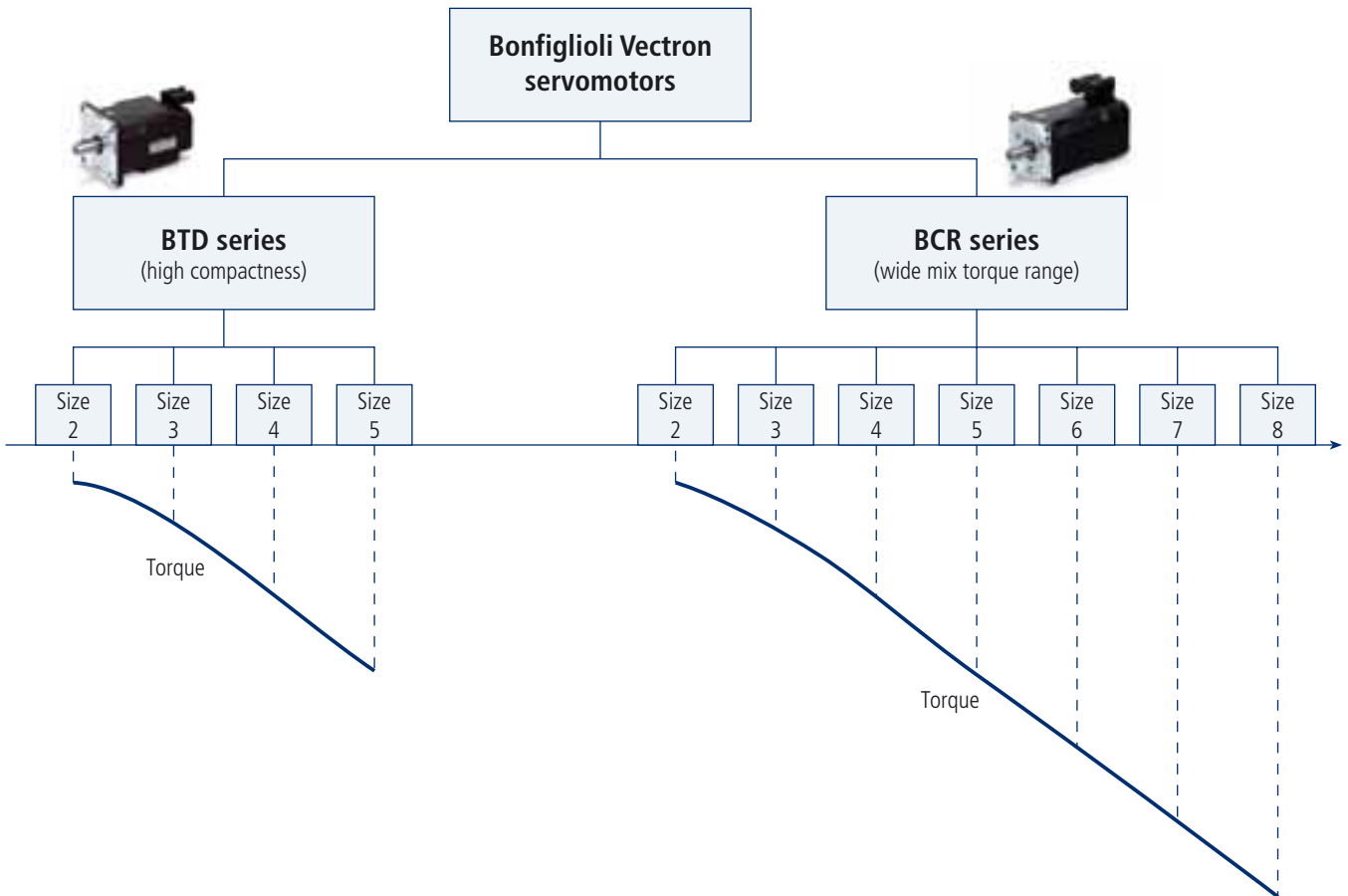

Match tables

For consistent match between Active Cube in "servo mode" and BTD/BCR servomotors ratings cross reference tables are below provided.

To choose best servo package for your needs, calculate max torque required by your application and compare it to the values within the table: best choice corresponds to the match servodrive-servomotor that gives at least needed max torque with a safety margin of 10%.

For more detailed dimensioning and in case of unusual torque profile or operating conditions, please refer to your local Drive Service Centre.

ACU 230V ↔ BTD 230V

ACTIVE CUBE drive	BTD servomotor															
	4500 rpm				3000 rpm											
	BTD2-0026	BTD2-0053	BTD2-0074	BTD2-0095	BTD3-0095	BTD3-0190	BTD3-0325	BTD3-0420	BTD4-0410	BTD4-0630	BTD4-0860	BTD5-1160	BTD5-1490	BTD5-1870	BTD5-2730	
ACU201-01	M _N	0,25	0,42	0,45		0,65										
	M _{MAX}	0,74	0,84	0,89		1,29										
ACU201-03	M _N		0,47	0,69	0,72	0,92	1,09									
	M _{MAX}		1,35	1,43	1,45	2,07	2,17									
ACU201-05	M _N			0,69	0,86	0,92	1,63		2,63							
	M _{MAX}			2,01	2,04	2,91	3,05		3,94							
ACU201-07	M _N			0,69	0,86	0,92	1,63	3,02	3,24	2,73						
	M _{MAX}			2,67	2,71	3,49	4,07	4,53	5,25	4,10						
ACU201-09	M _N				0,86		1,63	3,02	3,24	3,42						
	M _{MAX}				3,30		4,95	5,52	6,39	4,99						
ACU201-11	M _N							3,02	3,24	3,42	4,83	5,38				
	M _{MAX}							7,94	9,19	7,18	7,25	8,06				
ACU201-13	M _N							3,02	3,24	3,42	4,83	6,37				
	M _{MAX}							10,81	12,51	9,77	9,87	10,98				
ACU201-15	M _N									3,42	4,83	6,37	8,38	9,27		
	M _{MAX}									11,14	11,25	12,52	10,93	12,08		
ACU201-18	M _N										4,83	6,37	8,85	11,56		
	M _{MAX}										18,15	20,19	17,63	19,50		
ACU201-19	M _N											6,37	8,85	11,56	14,75	18,54
	M _{MAX}											23,27	20,32	22,46	20,31	25,53
ACU201-21	M _N												8,85	11,56	15,01	21,40
	M _{MAX}												29,84	32,99	29,83	37,50
ACU201-22	M _N												8,85	11,56	15,01	21,40
	M _{MAX}												34,53	38,18	34,52	43,39

Note:

For servomotor ratings and description, please refer to relevant catalogue.

- 0,00 ⇐ Continuous torque
- 0,00 ⇐ Max torque

ACU 400V ↔ BTD 400V

ACTIVE CUBE drive	BTd servomotor														
	4500 rpm				3000 rpm										
	BTd-0026	BTd-0053	BTd-0074	BTd-0095	BTd3-0095	BTd3-0190	BTd3-0325	BTd3-0420	BTd4-0410	BTd4-0630	BTd4-0860	BTd5-1160	BTd5-1490	BTd5-1870	BTd5-2730
M _N	0,42	0,48	0,69	0,73	0,72	1,14									
M _{MAX}	1,05	1,45	1,54	1,45	1,44	2,29									
M _N			0,69	0,86	0,92	1,67									
M _{MAX}			2,47	2,32	2,30	3,66									
M _N			0,69	0,86	0,92	1,67	2,44	2,52							
M _{MAX}			2,08	1,96	1,94	3,09	3,66	3,78							
M _N				0,86	0,92	1,67	3,11	3,22	2,89						
M _{MAX}				2,61	2,59	4,12	4,88	5,04	4,34						
M _N					0,92	1,67	3,11	3,22	3,38	4,23					
M _{MAX}					3,45	5,49	6,50	6,72	5,79	6,34					
M _N						1,67	3,11	3,22	3,38	4,75					
M _{MAX}					6,52	7,72	7,98	6,87	7,53						
M _N							3,11	3,22	3,38	4,75	5,64				
M _{MAX}							8,53	8,82	7,60	8,32	8,47				
M _N							3,11	3,22	3,38	4,75	6,45				
M _{MAX}							11,78	12,18	10,49	11,49	11,69				
M _N										4,75	6,45	8,70			
M _{MAX}										15,45	15,72	13,05			
M _N										4,75	6,45	8,81	10,73	10,26	
M _{MAX}										17,83	18,14	15,06	16,09	15,39	
M _N												8,81	11,44	14,94	20,12
M _{MAX}												23,42	25,03	23,95	30,17
M _N												8,81	11,44	14,94	21,41
M _{MAX}												29,33	31,35	29,99	37,79
M _N												8,81	11,44	14,94	21,41
M _{MAX}												33,80	36,12	34,55	43,54
M _N													11,44	14,94	21,41
M _{MAX}													44,70	42,76	53,88
M _N														14,94	21,41
M _{MAX}														50,74	63,94

Note: For servomotor ratings and description, please refer to relevant catalogue.

0,00 ↔ Continuous torque
0,00 ↔ Max torque

ACU 230V ↔ BCR 230V

ACTIVE CUBE drive	BCR servomotor																								
	4500 rpm										3000 rpm														
	BCR2-0020	BCR2-0040	BCR2-0060	BCR2-0080	BCR3-0065	BCR3-0130	BCR3-0250	BCR3-0300	BCR4-0100	BCR4-0260	BCR4-0530	BCR4-0750	BCR5-0660	BCR5-1050	BCR5-1350	BCR5-1700	BCR5-2200	BCR6-1350	BCR6-1900	BCR6-2200	BCR6-2900	BCR7-2700	BCR7-3200	BCR7-4000	
M_N	0,20	0,38	0,49	0,51	0,47																				
M_{MAX}	0,68	0,86	0,98	1,03	0,94																				
M_N		0,38	0,58	0,75	0,62	0,87			0,87																
M_{MAX}		1,38	1,56	1,64	1,51	1,73		1,75																	
M_N			0,58	0,75	0,62	1,08	1,88	0,98	2,52																
M_{MAX}			2,20	2,31	2,12	2,44	2,81	2,46	3,77																
M_N				0,75		1,08	2,13	0,98	2,52																
M_{MAX}				3,08		3,25	3,75	3,28	5,03																
M_N						1,08	2,13	2,25	2,52	4,40		4,63													
M_{MAX}						3,95	4,56	4,56	6,12	5,95		6,26													
M_N						2,13	2,25		2,52	4,81	5,77	5,83													
M_{MAX}						6,56	6,56	6,56	8,81	8,56	8,65	9,00													
M_N							2,25	2,25		4,81	6,68	5,83	7,44												
M_{MAX}							8,94	8,94		11,66	11,79	12,26	11,21												
M_N										4,81	6,68	5,83	9,01	9,70	11,55		11,56								
M_{MAX}										13,29	13,43	13,97	12,77	12,65	15,06		15,07								
M_N										6,68	5,83	9,01	11,25	14,78	15,47		13,50	14,87							
M_{MAX}										21,68	22,54	20,61	20,41	24,30	22,60		24,32	21,73							
M_N										6,68	6,68	9,01	11,25	14,78	17,36		13,50	17,60							
M_{MAX}										24,97	24,97	23,74	23,51	27,99	26,04		28,02	25,03							
M_N												9,01	11,25	14,78	17,36		13,50	17,60							
M_{MAX}												34,87	34,53	41,11	38,24		41,15	36,76							
M_N													11,25	14,78	17,36		13,50	17,60							
M_{MAX}													39,96	47,58	44,26		47,62	42,54							

Note: For servomotor ratings and description, please refer to relevant catalogue.

Note:

0,00 ⇐ Continuous torque

0,00 ⇐ Max torque

ACU 400V ↔ BCR 400V

ACTIVE CUBE drive		BCR servomotor																													
		4500 rpm								3000 rpm								2000 rpm													
M _N	M _{MAX}	BCR2-0020	BCR2-0040	BCR2-0060	BCR2-0080	BCR3-0065	BCR3-0130	BCR3-0250	BCR3-0300	BCR4-0100	BCR4-0260	BCR4-0530	BCR4-0750	BCR5-0660	BCR5-1050	BCR5-1350	BCR5-1700	BCR5-2200	BCR6-1900	BCR6-2200	BCR6-2900	BCR7-2700	BCR7-3200	BCR7-4000	BCR8-0400	BCR8-0680	BCR8-0930	BCR8-1150			
0,20	0,38	0,58	0,76	0,62	0,91					0,94																					
0,85	1,48	1,64	1,76	1,65	1,82					1,89																					
M _N	M _N	0,58	0,76	0,62	1,13					0,99																					
M _{MAX}	M _{MAX}	2,55	2,81	2,63	2,91					3,02																					
M _N	M _N	0,58	0,76	0,62	1,13	1,73	2,08	2,31	2,51	0,99	2,44																				
M _{MAX}	M _{MAX}	2,22	2,37	2,22	2,45	2,60	3,12	2,55	3,66	2,55	3,66																				
M _N	M _N		0,76			1,13	2,12	2,31	2,51	0,99	4,88																				
M _{MAX}	M _{MAX}		3,16			3,27	3,46	4,15	3,40	4,88																					
M _N	M _N					1,13	2,12	2,31	2,51	3,40	4,88																				
M _{MAX}	M _{MAX}					4,36	4,62	5,54	6,50	6,50	6,50																				
M _N	M _N					2,12	2,31		2,51	4,91	5,72	5,72	5,72	5,72	5,72	5,72	5,72	5,72	5,72	5,72	5,72	5,72	5,72	5,72	5,72	5,72	5,72	5,72	5,72		
M _{MAX}	M _{MAX}					5,48	6,58		7,72	7,37	8,36	8,36	8,36	8,36	8,36	8,36	8,36	8,36	8,36	8,36	8,36	8,36	8,36	8,36	8,36	8,36	8,36	8,36	8,36		
M _N	M _N					2,12	2,31		2,51	4,91	5,72	5,72	5,72	5,72	5,72	5,72	5,72	5,72	5,72	5,72	5,72	5,72	5,72	5,72	5,72	5,72	5,72	5,72	5,72		
M _{MAX}	M _{MAX}					6,06	7,27		8,53	8,14	9,84	9,24	9,24	9,24	9,24	9,24	9,24	9,24	9,24	9,24	9,24	9,24	9,24	9,24	9,24	9,24	9,24	9,24	9,24	9,24	
M _N	M _N					2,12	2,31		2,51	4,91	5,72	5,72	5,72	5,72	5,72	5,72	5,72	5,72	5,72	5,72	5,72	5,72	5,72	5,72	5,72	5,72	5,72	5,72	5,72	5,72	
M _{MAX}	M _{MAX}					8,37			11,25	13,59	12,76	12,51	12,51	12,51	12,51	12,51	12,51	12,51	12,51	12,51	12,51	12,51	12,51	12,51	12,51	12,51	12,51	12,51	12,51	12,51	
M _N	M _N								4,91	6,88	5,87	8,34	8,34	8,34	8,34	8,34	8,34	8,34	8,34	8,34	8,34	8,34	8,34	8,34	8,34	8,34	8,34	8,34	8,34	8,34	
M _{MAX}	M _{MAX}								11,25	15,12	18,28	17,16	16,83	16,83	16,83	16,83	16,83	16,83	16,83	16,83	16,83	16,83	16,83	16,83	16,83	16,83	16,83	16,83	16,83	16,83	16,83
M _N	M _N								4,91	6,88	5,87	8,34	8,34	8,34	8,34	8,34	8,34	8,34	8,34	8,34	8,34	8,34	8,34	8,34	8,34	8,34	8,34	8,34	8,34	8,34	
M _{MAX}	M _{MAX}								17,45	21,09	19,80	19,42	19,42	19,42	19,42	19,42	19,42	19,42	19,42	19,42	19,42	19,42	19,42	19,42	19,42	19,42	19,42	19,42	19,42	19,42	19,42
M _N	M _N								9,06	11,45	14,91	18,05	17,62	17,62	17,62	17,62	17,62	17,62	17,62	17,62	17,62	17,62	17,62	17,62	17,62	17,62	17,62	17,62	17,62	17,62	17,62
M _{MAX}	M _{MAX}								30,21	31,70	39,22	45,20	43,30	43,30	43,30	43,30	43,30	43,30	43,30	43,30	43,30	43,30	43,30	43,30	43,30	43,30	43,30	43,30	43,30	43,30	43,30
M _N	M _N								11,45	14,91	18,05	17,62	17,62	17,62	17,62	17,62	17,62	17,62	17,62	17,62	17,62	17,62	17,62	17,62	17,62	17,62	17,62	17,62	17,62	17,62	17,62
M _{MAX}	M _{MAX}								36,52	45,18	52,08	49,88	49,88	49,88	49,88	49,88	49,88	49,88	49,88	49,88	49,88	49,88	49,88	49,88	49,88	49,88	49,88	49,88	49,88	49,88	49,88
M _N	M _N								11,45	14,91	18,05	17,62	17,62	17,62	17,62	17,62	17,62	17,62	17,62	17,62	17,62	17,62	17,62	17,62	17,62	17,62	17,62	17,62	17,62	17,62	17,62
M _{MAX}	M _{MAX}								45,20	55,92	64,45	64,45	64,45	64,45	64,45	64,45	64,45	64,45	64,45	64,45	64,45	64,45	64,45	64,45	64,45	64,45	64,45	64,45	64,45	64,45	64,45
M _N	M _N								11,45	14,91	18,05	17,62	17,62	17,62	17,62	17,62	17,62	17,62	17,62	17,62	17,62	17,62	17,62	17,62	17,62	17,62	17,62	17,62	17,62	17,62	17,62
M _{MAX}	M _{MAX}								61,27	74,95	72,06	81,65	81,65	81,65	81,65	81,65	81,65	81,65	81,65	81,65	81,65	81,65	81,65	81,65	81,65	81,65	81,65	81,65	81,65	81,65	81,65
M _N	M _N								25,26	28,99	32,66	32,66	32,66	32,66	32,66	32,66	32,66	32,66	32,66	32,66	32,66	32,66	32,66	32,66	32,66	32,66	32,66	32,66	32,66	32,66	32,66
M _{MAX}	M _{MAX}								101,05	97,17	110,09	160,63	168,58	163,90	163,90	163,90	163,90	163,90	163,90	163,90	163,90	163,90	163,90	163,90	163,90	163,90	163,90	163,90	163,90	163,90	163,90
M _N	M _N								28,99	32,66	36,33	36,33	36,33	36,33	36,33	36,33	36,33	36,33	36,33	36,33	36,33	36,33	36,33	36,33	36,33	36,33	36,33	36,33	36,33	36,33	36,33
M _{MAX}	M _{MAX}								109,31	123,85	180,71	189,65	184,38	184,38	184,38	184,38	184,38	184,38	184,38	184,38	184,38	184,38	184,38	184,38	184,38	184,38	184,38	184,38	184,38	184,38	184,38
M _N	M _N								71,08	88,50	71,08	88,50	88,50	88,50	88,50	88,50	88,50	88,50	88,50	88,50	88,50	88,50	88,50	88,50	88,50	88,50	88,50	88,50	88,50	88,50	88,50
M _{MAX}	M _{MAX}								252,87	245,84	252,87	245,84	245,84	245,84	245,84	245,84	245,84	245,84	245,84	245,84	245,84	245,84	245,84	245,84	245,84	245,84	245,84	245,84	245,84	245,84	245,84
M _N	M _N								307,30	307,30	307,30	307,30	307,30	307,30	307,30	307,30	307,30	307,30	307,30	307,30	307,30	307,30	307,30	307,30	307,30	307,30	307,30	307,30	307,30	307,30	307,30
M _{MAX}	M _{MAX}								307,30	307,30	307,30	307,30	307,30	307,30	307,30	307,30	307,30	307,30	307,30	307,30	307,30	307,30	307,30	307,30	307,30	307,30	307,30	307,30	307,30	307,30	307,30

Note: For servomotor ratings and description, please refer to relevant catalogue.

0,00 ↔ Continuous torque
0,00 ↔ Max torque

A wide range of mechanical accessories is available for Active Cube Series frequency converters, to make installation extremely easy in all sorts of applications.

In standard mountings the unit can be installed directly on the mounting plate or through-the-wall. A vibration-proof mounting variant and a standard DIN bar mounting variant are also available.

The range of mounting variants also includes an optional support with shielded brackets, so that the right solution for all possible needs can always be found.

Installations are practically identical for all sizes, so the examples shown below can be taken as representative solutions and ideal for all installers seeking a mechanically simple, compact installation solution.

Types of mounting kits

The drive is supplied complete with a standard installation kit for fixing to an electrical cabinet mounting panel.

3 different optional installation kits are available on request.

MPSV

Thru-type assembly for higher protection classes or enhanced cooling characteristics

MNVIB

Anti-vibration mounting for installations on machines that generate significant vibrational stress

MDIN

DIN rail assembly for fast and modular installation / coupling

Size 1

Standard assembly

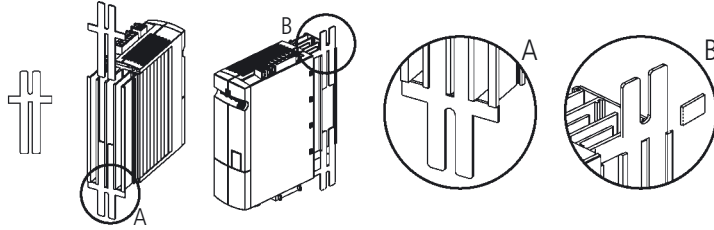

Inverter BONFIGLIOLI

Mounting

Description

ACU 201-01 ... ACU 201-09
ACU 401-01 ... ACU 401-11

MPSV1

Thru-type assembly

MNVIB1

Antivibration assembly

MDIN1

DIN rail assembly

MPSV1

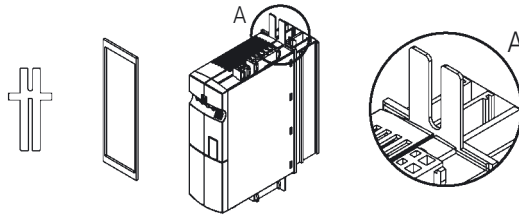

MNVIB1

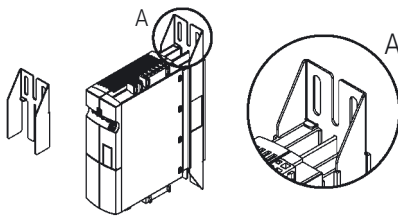

MDIN1

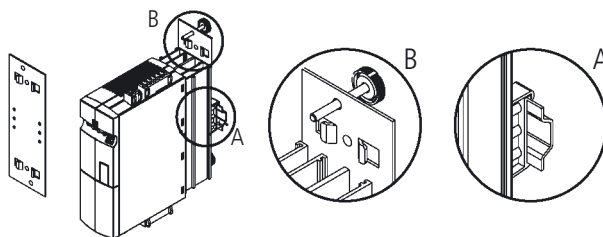

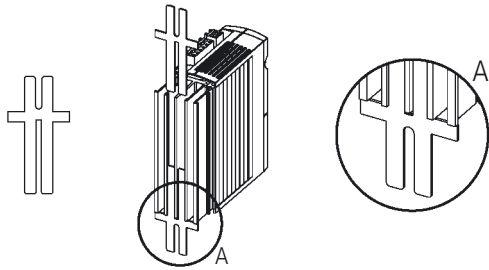

Standard assembly

Size 2

Inverter BONFIGLIOLI	Mounting	Description
ACU 201-11 ... ACU 201-15	MPSV2	Thru-type assembly
ACU 401-12 ... ACU 401-18	MNVIB2	Antivibration assembly
	MDIN2	DIN rail assembly

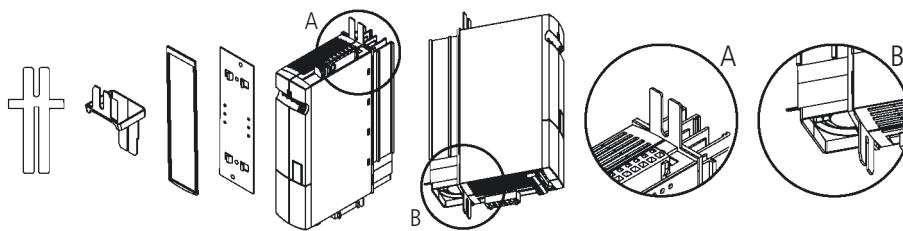

MPSV2

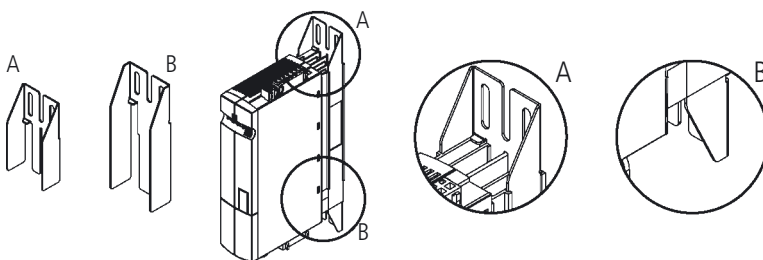

MNVIB2

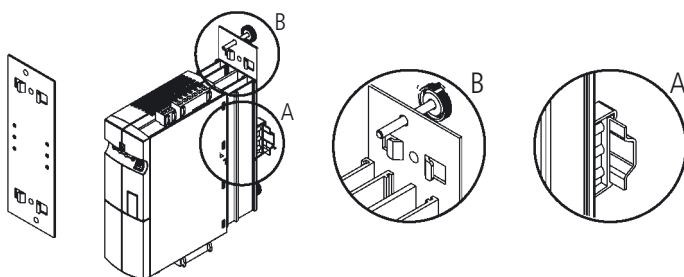

MDIN2

Size 3

Standard assembly

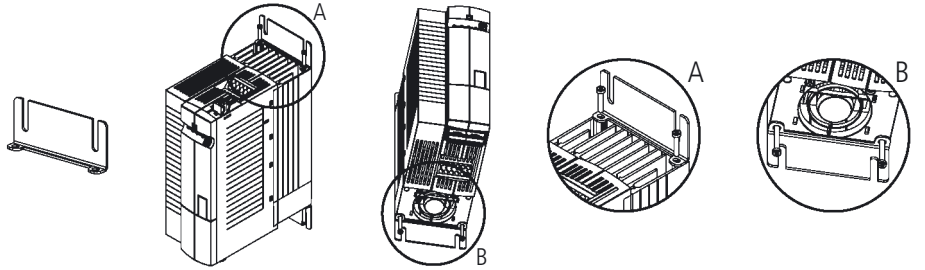

Inverter BONFIGLIOLI

ACU 201-18 ... ACU 201-19
ACU 401-19 ... ACU 401-22

Mounting

MPSV3
MNVIB3

Description

Thru-type assembly
Antivibration assembly

MPSV3

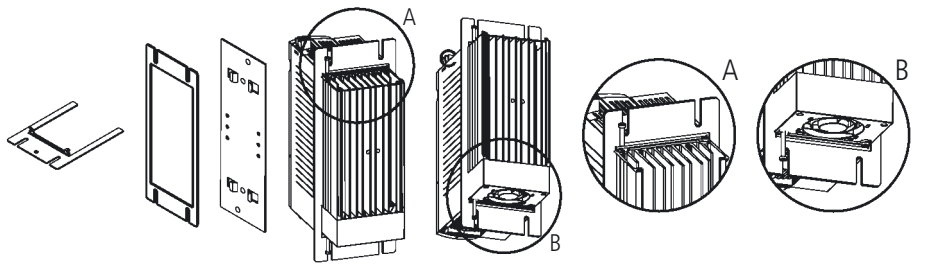

MNVIB3

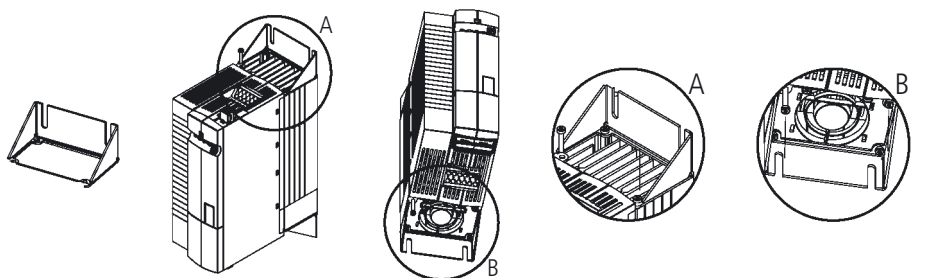

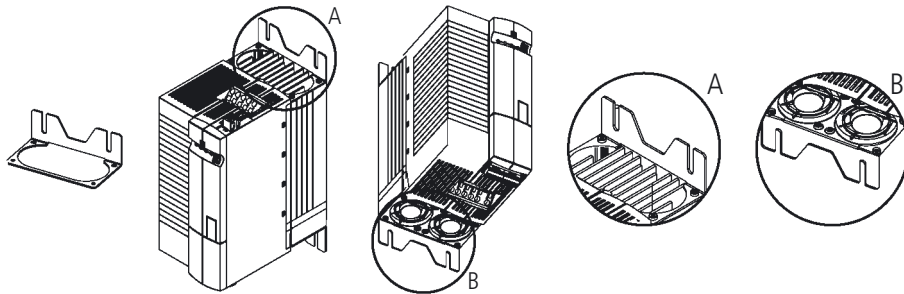

Standard assembly

Size 4

Inverter BONFIGLIOLI	Mounting	Description
ACU 201-21 ... ACU 201-22	MPSV4	Thru-type assembly
ACU 401-23 ... ACU 401-25	MNVIB4	Antivibration assembly

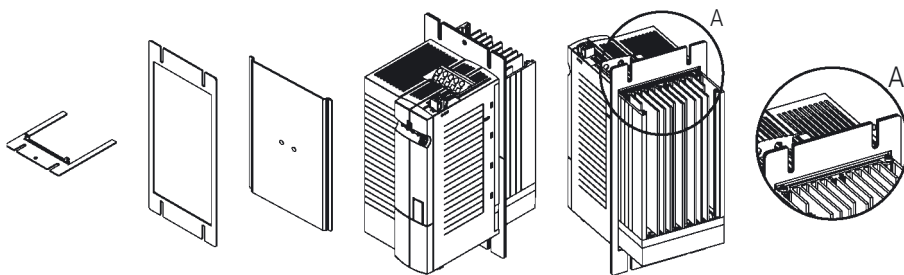

MPSV4

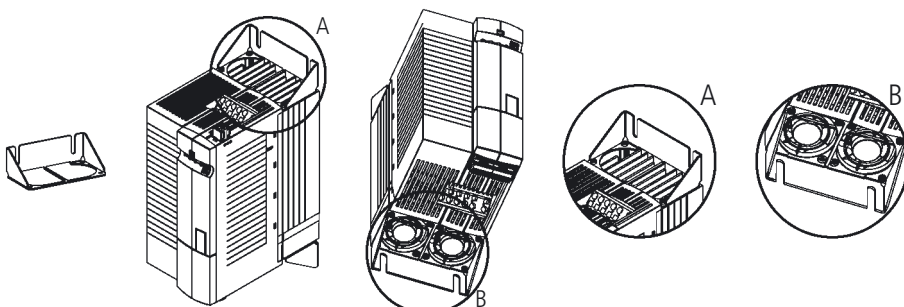

MNVIB4

Size 5

Standard assembly

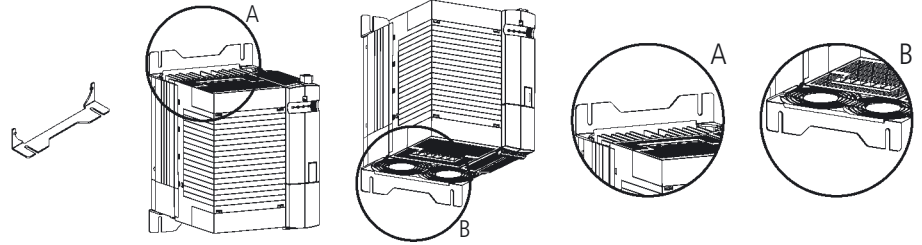

Inverter BONFIGLIOLI

Mounting

Description

ACU 401-27 ... ACU 401-31

MPSV5

Thru-type assembly

MNVIB5

Antivibration assembly

MPSV5

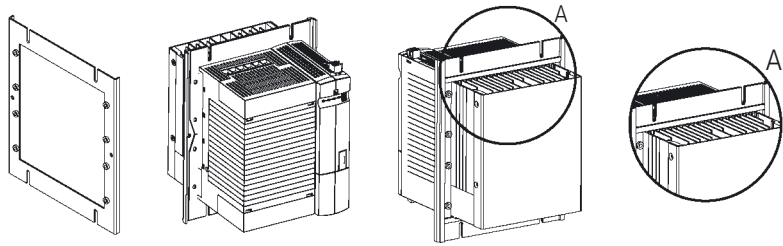

MNVIB5

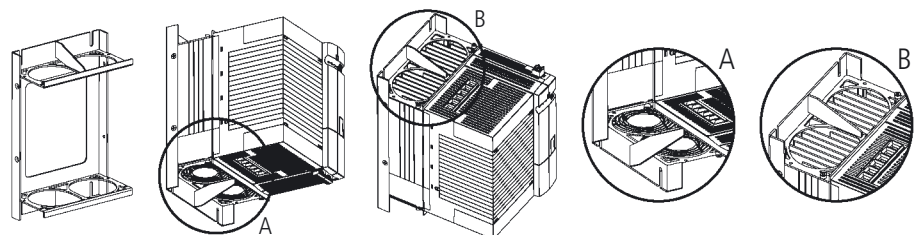

Standard assembly

Size 6

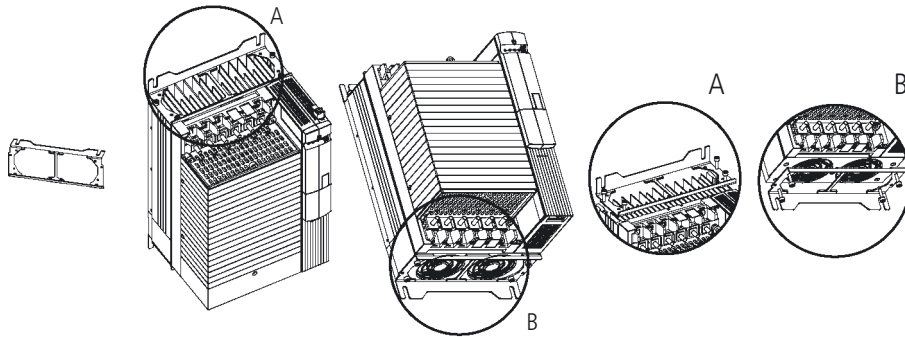

Inverter BONFIGLIOLI	Mounting	Description
ACU 401-33 ... ACU 401-39	MPSV6	Thru-type assembly
	MNVIB6	Antivibration assembly

MPSV6

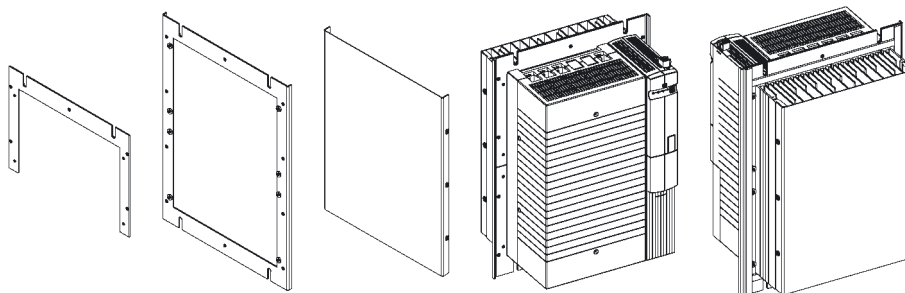

MNVIB6

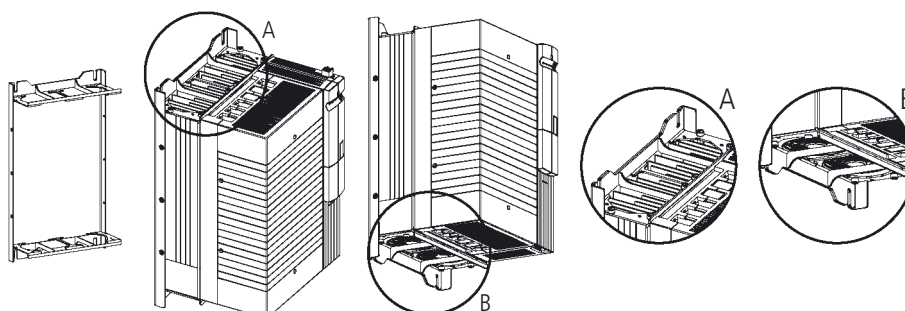

Active Cube

Mounting

Size 7

Standard assembly

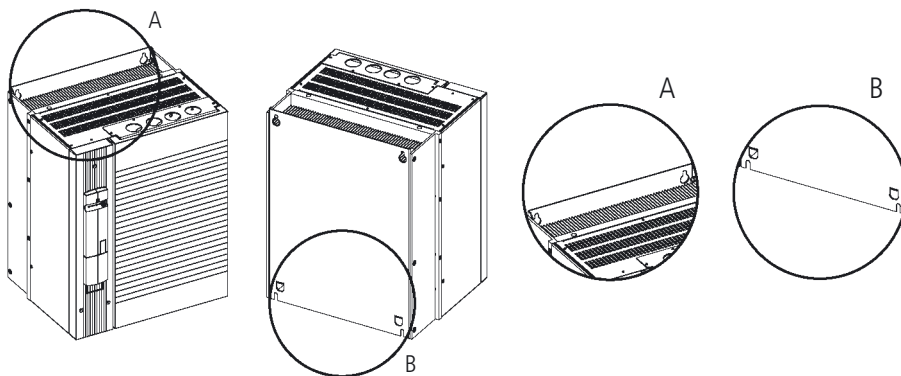

Inverter BONFIGLIOLI

ACU 401-43...ACU 401-49

Mounting

MPSV7

Description

Thru-type assembly

MPSV7

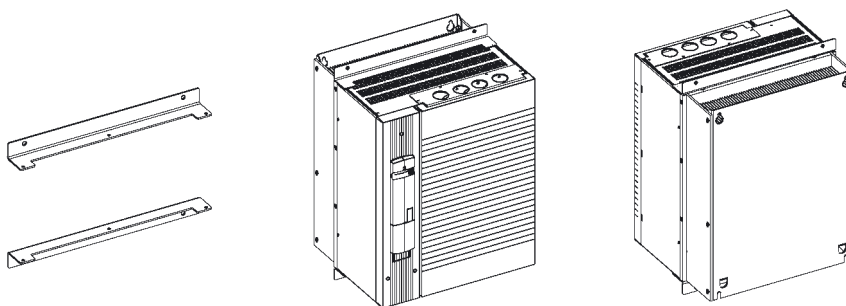

Input filter

Why an input filter?

An Input Filter is a filtration device to be installed up-line from the frequency inverter and down-line from the power feeding contactor.

The AC/DC rectifier at the inverter input generates harmonic disturbance on the absorbed current and returns disturbance generated by switching components towards the mains. This harmonic current causes voltage distortions on the mains resulting in electromagnetic interference phenomena.

This harmonic distortion is reduced by means of line chokes, while disturbance is countered with EMI filters (attenuation of EMI voltages) such as those described below.

Note: The use of input filters reduces the inverter input voltage. If required, these filters should be installed up-line from the inverter in the following order:

1. Mains supply
2. Line choke
3. EMI filter
4. Inverter

Line choke

- Line chokes are not mandatory: their use depends on the system engineer's need to reduce harmonic distortion in the short circuit point, and the need to reinforce the action of the EMI filter. A line choke is normally used if the mains short circuit power is lower than 1%.
- A line choke is recommended for the ACU201 and ACU401 frequency inverter series in the presence of high continuous input current required by the application, in order to increase the lifetime of the electrolytic capacitors.
- A line choke is always required in single and two-phase operation of the ACU201 frequency inverters.

EMI filter

- An EMI filter can be used in order to achieve Class "A" (groups 1, 2) or Class "B" interference suppression
- The EMI filter is available in a low leakage current version for special applications.
- The EMI - filter is part of the standard outfit in sizes of up to 4.0 kW and it is supplied as an optional for higher sizes in an internal (up to 7.5 kW) or external (above 7.5 kW) version.

Power feeding line

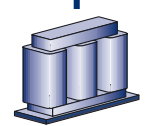

Line choke



Power feeding line



EMI filter



Input filter

ACTIVE CUBE inverter - Line choke / EMI filter combination

	Motor Cable Length	Compliance with Class A Group 2		Compliance with Class A Group 1		Compliance with Class B	
		< 10 m	< max*	< 10 m	< max*	< 10 m	< max*
ACU 1 (Standard internal filter)	Standard	Standard	external choke	external choke	external filter	external choke	external filter
ACU 2 (Standard internal filter)	Standard	Standard	external choke	external choke	external filter	external choke	external filter
ACU 3	internal filter or external choke	internal filter or external choke	internal filter + external choke	internal filter + external choke	external filter	external filter + external choke	external filter
ACU 4	external choke	external filter	external filter	external filter	external filter	external filter + external choke	external filter + external choke
ACU 5	external choke	external choke	external filter	external filter	external filter	external filter + external choke	external filter + external choke
ACU 6	external choke	external choke	external filter	external filter	external filter	external filter	external filter
ACU 7	external choke	external choke	external filter	external filter	external filter	—	—

* See the operation manual

Line choke



The simplest way of reducing high harmonic components and hence reactive power is connecting a choke in series on the mains side of the inverter. Depending on the system, reactive power consumption can be reduced by approximately 20% of the figure without line choke.

The line choke increases inductance towards the mains. Mains feed line choke can be regarded as sufficient if short-circuit power is from 20 to 40 times higher than the inverter nominal output.

The inverter is suitable for connection to public or industrial mains supplies in compliance with technical data. If the supply mains transformer output is ≤ 500 kVA, the optional mains choke is needed only if specified in the inverter technical data. The other inverters are suitable for the connection to the mains without a mains choke with relative impedance $\geq 1\%$. If it is desired to connect more than one inverter, use the sum of the nominal outputs as a basis.

Since experience has shown that the nominal short circuit power on the inverter connection point is often unknown, BONFIGLIOLI recommends the use of mains chokes with 4% voltage drop.

The relative short circuit voltage equivalent to a 4% voltage drop represents the percentage of the nominal voltage at which a current equal to rated current flows in the case of a short circuit.

The European reference standard for harmonics is EN 60 555, while in the US and Canada systems must comply with standard IEEE 519 and various generic national regulations.

Technical data

Nominal voltages

230V +/- 10%
400V +/- 10%

Frequencies

50/60 Hz
uk (a IN / 50 Hz) 4%

Insulating material class

T40/F

Ambient temperature

40°C

Protection class

IP00 / VBG4

Connection type

Contact-protected terminals

Note: The line choke must be installed between the mains connection point and the EMI filter. Both the line choke and inverter should be installed on a common metal baseplate and each should be connected to the metal mounting plate and earthed by means of a large contact area copper braid.

Line choke

Dimensions

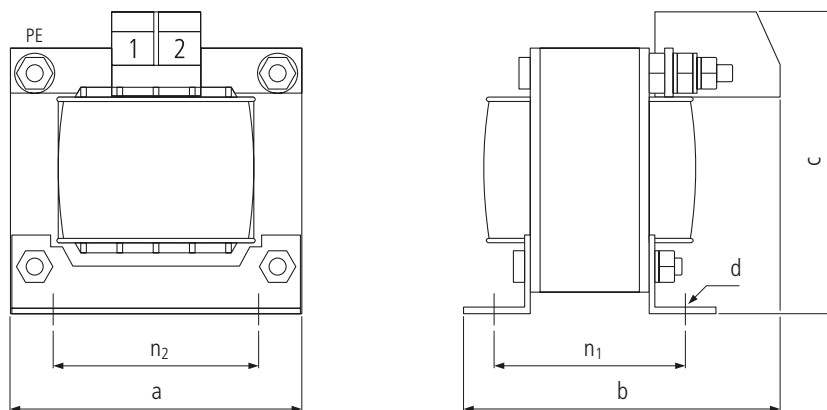

Technical data

BONFIGLIOLI frequency inverter – Line choke combination, **1x230V~**

BONFIGLIOLI Inverter	BONFIGLIOLI Choke	Nominal current	Power dissipation
		[A]	[W]
ACU 201-01	LCVS006	6	8.0
ACU 201-03			
ACU 201-05			
ACU 201-07	LCVS008	8	8.0
ACU 201-09	LCVS010	10	10.0
ACU 201-11	LCVS015	15	12.0
ACU 201-13	LCVS018	18	15.0

Technical assembly data

BONFIGLIOLI Choke	Dimensions			Assembly			Weight	Connection terminal		
	a	b	c	n ₂	n ₁	d		[mm]	[Nm]	PE
	[mm]	[mm]	[mm]	[mm]	[mm]	[mm]	[kg]			
LCVS006	60	62	75	44	38	3.6	0.5	0.75-2.5	1.0-1.2	2.5 mm ²
LCVS008	60	67	75	44	43	3.6	0.6	0.75-2.5	1.0-1.2	2.5 mm ²
LCVS010	66	80	70	50	51	4.8	0.8	0.75-2.5	1.0-1.2	M4
LCVS015	78	78	80	56	49	4.8	1.1	0.75-4.0	1.5-1.8	M4
LCVS018	85	85	95	64	50	4.8	1.8	0.75-4.0	1.5-1.8	M4

Line choke

Dimensions

LCVT004 ... LCVT025

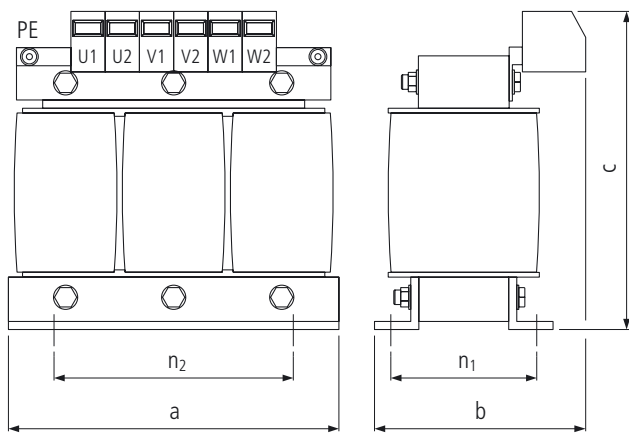

LCVT034 ... LCVT250

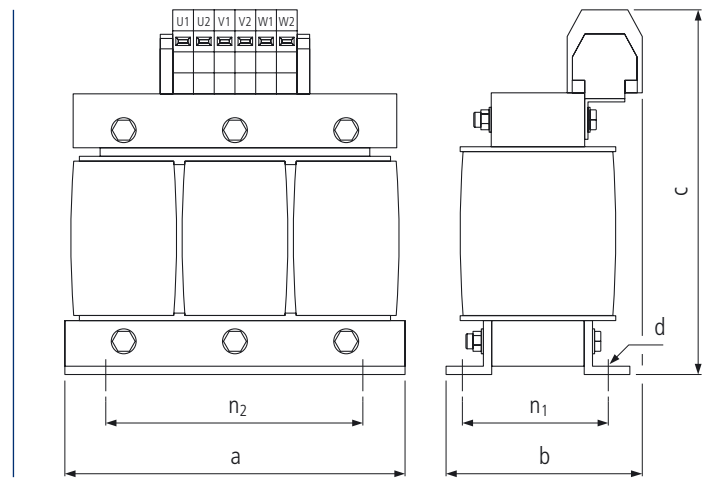

BONFIGLIOLI frequency inverter – Line choke combination, **3x230V~**

Technical data

BONFIGLIOLI Inverter	BONFIGLIOLI Choke	Nominal current	Choke	Power dissipation
		[A]	[mH]	[W]
ACU 201-01	LCVT004	4	7,32	20
ACU 201-03				
ACU 201-05				
ACU 201-07				
ACU 201-09	LCVT006	6	4,88	25
ACU 201-11	LCVT008	8	3,66	30
ACU 201-13	LCVT010	10	2,93	30
ACU 201-15	LCVT015	15	1,95	45
ACU 201-18	LCVT018	18	1,63	70
ACU 201-19	LCVT025	25	1,17	70
ACU 201-21	LCVT034	34	0,86	85
ACU 201-22				

Line choke

Technical data

BONFIGLIOLI frequency inverter – Line choke combination, **3x400V~**

BONFIGLIOLI Inverter	BONFIGLIOLI Choke	Nominal current	Choke	Power dissipation
		[A]	[mH]	[W]
ACU 401-01	LCVT004	4	7,32	20
ACU 401-03				
ACU 401-05				
ACU 401-07				
ACU 401-09				
ACU 401-11				
ACU 401-12				
ACU 401-13	LCVT006	6	4,88	25
ACU 401-15	LCVT008	8	3,66	30
ACU 401-18	LCVT010	10	2,93	30
ACU 401-19	LCVT015	15	1,95	45
ACU 401-21	LCVT018	18	1,63	70
ACU 401-22	LCVT025	25	1,17	70
ACU 401-23	LCVT025	25	0,86	85
ACU 401-25	LCVT034	34	0,86	85
ACU 401-27	LCVT050	50	0,59	100
ACU 401-29	LCVT060	60	0,49	100
ACU 401-31				
ACU 401-33	LCVT075	75	0,37	110
ACU 401-35	LCVT090	90	0,33	120
ACU 401-37	LCVT115	115	0,25	140
ACU 401-39	LCVT135	135	0,22	180
ACU 401-43	LCVT160	160	0,18	180
ACU 401-45	LCVT180	180	0,16	185
ACU 401-47	LCVT210	210	0,14	200
ACU 401-49	LCVT250	250	0,12	210

Technical assembly data

BONFIGLIOLI Choke	Dimensions			Assembly			Weight	Connection terminal		
	a	b	c	n ₂	n ₁	d		[mm]	[Nm]	PE
	[mm]	[mm]	[mm]	[mm]	[mm]	[mm]				
LCVT004	80	65	95	55	37	4	0,8	0,75-2,5	1,0-1,2	4 mm ²
LCVT006	100	65	115	60	39	4	1,0	0,75-2,5	1,0-1,2	4 mm ²
LCVT008	100	75	115	60	48	4	1,5	0,75-2,5	1,0-1,2	4 mm ²
LCVT010	100	75	115	60	48	4	1,5	0,75-2,5	1,0-1,2	4 mm ²
LCVT015	125	85	135	100	55	5	3,0	0,75-4,0	1,5-1,8	4 mm ²
LCVT018	155	90	135	130	57	8	4,0	0,75-4,0	1,5-1,8	4 mm ²
LCVT025	155	100	160	130	57	8	4,0	0,75-10	4,0-4,5	4 mm ²
LCVT034	155	100	190	130	57	8	4,5	2,5-16	2,0-4,0	M5
LCVT050	155	115	190	130	72	8	4,5	2,5-16	2,0-4,0	M5
LCVT060	190	110	220	170	58	8	9,0	2,5-35	2,5-5,0	M5
LCVT075	190	120	250	170	68	8	12	25-50	3,0-6,0	M6
LCVT090	190	130	250	170	78	8	12	25-50	3,0-6,0	M6
LCVT115	210	140	270	180	82	8	14	25-50	3,0-6,0	M6
LCVT135	240	160	300	190	100	11	20	16-70	6,0-7,0	M8
LCVT160	240	160	310	190	100	11	20	50-95	6,0-12,0	M8
LCVT180	240	175	320	190	106	11	22	50-95	6,0-12,0	M8
LCVT210	240	200	335	190	121	11	26	95-150	10,0-20,0	M8
LCVT250	240	210	350	190	126	11	28	95-150	10,0-20,0	M8

EMI filters

Because of their intrinsic characteristics, all frequency inverters often generate undesired high frequency voltages generally referred to as "interference". Mains filters are installed to reduce this interference.

Within the European Union reference standard EN 61800-3 defines the thresholds for electromagnetic interference for different classes of equipment.

Active Series frequency inverters up to size 9.2 kW can be ordered with a built-in EMI filter conforming to the requirements of the standard for "class A – group 2" environments.

Two series of external interference filters are available for larger size Active frequency inverters and for installations where conformity to the stricter requirements of class B is necessary. The two series differ both in construction and power range.

The first set of filters are "backplate filters or foot print". They are available in sizes 7 to 40 A (suitable for Active frequency inverters up to size 4), and allow the frequency inverter to be installed on board the filter itself. The second series of filters are "book filters". They cover all other Active sizes up to 130 A and are designed for installation on the same mounting panel alongside the drive.

Mains filters with very low dispersion currents are available upon request for specific applications.

Basic circuit diagram

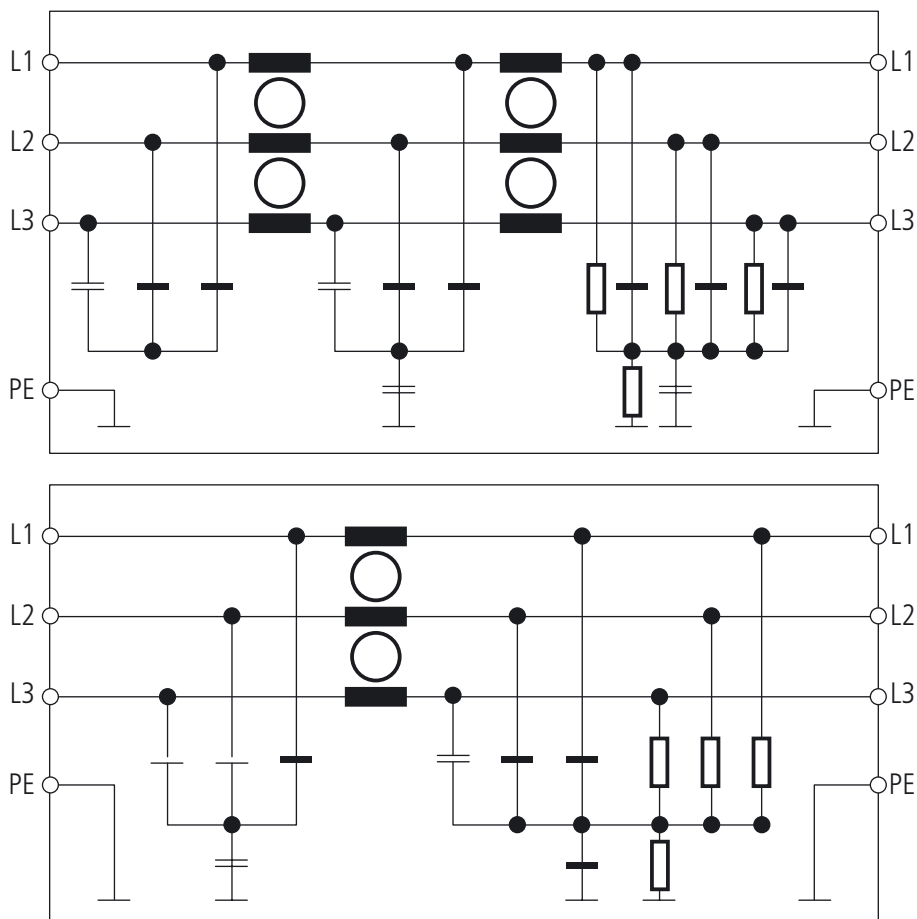

Backplate EMI filters



Mains voltage

3 x 480V~ maximum +10%

Nominal current

8A ... 40A

Frequency

50/60 Hz

Operating and storage temperature

-25 °C ... +100 °C (climate class acc. to CEI 25/100/21)

Ambient temperature

+40°C maximum

Protection class

IP00

Connection type

Contact-protected terminals

Strand connection on load side (only up to ACU 401-18)

Metal fasteners are included in the supply

Note: These mains filters are installed between the line choke and the frequency inverter. The frequency inverter installed on the EMI filter must be connected to the metal baseplate with a short, large section earth connection.

Overload capacity is 1.5 times rated current for 1 minute, every 30 minutes.

BONFIGLIOLI Inverter		BONFIGLIOLI EMI filter	Rated current	Leakage current	Power dissipation	Weight
Size	Type		[A]	[mA]	[W]	[kg]
1	ACU 201-01	FTV007B	8	5	10	1,5
	ACU 201-03					
	ACU 201-05					
	ACU 201-07					
	ACU 201-09					
	ACU 401-01					
	ACU 401-03					
	ACU 401-05					
	ACU 401-07					
	ACU 401-09					
	ACU 401-11					
2	ACU 201-11	FTV018B	18	1,5	20	3,5
	ACU 401-12					
	ACU 401-13					
	ACU 401-15					
	ACU 401-18					
3	ACU 401-19	FTV040B	40	1,2	35	3,5
	ACU 401-21					
4	ACU 401-23	FTV040B	40	1,2	35	3,5
	ACU 401-25					

Backplate EMI filters

Dimensions
FTV007B

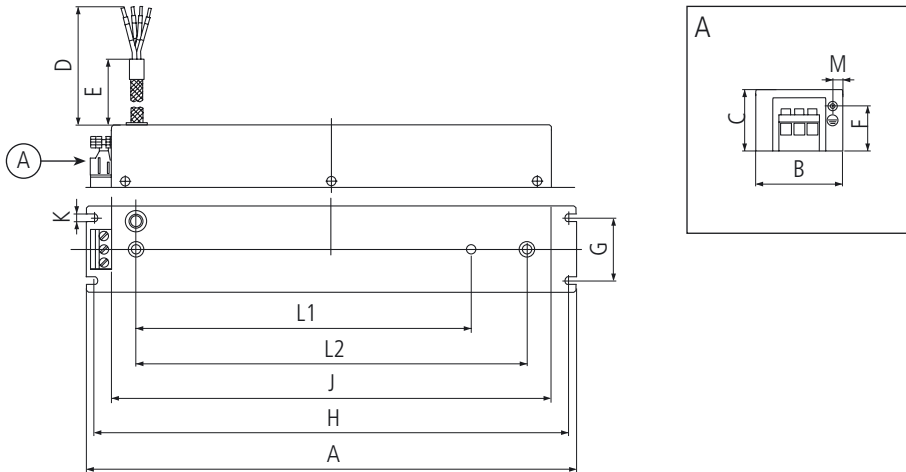

BONFIGLIOLI EMI filter	A [mm]	B [mm]	C [mm]	D [mm]	E [mm]	F [mm]	G [mm]	H [mm]	J [mm]	K [mm]	L1 [mm]	L2 [mm]	M [mm]
FTV007B	351	62	45	200±10	160±10	33	45±0.2	340±0.3	315	5.5	240±0.2	280±0.2	7

Dimensions
FTV018B - FTV040B

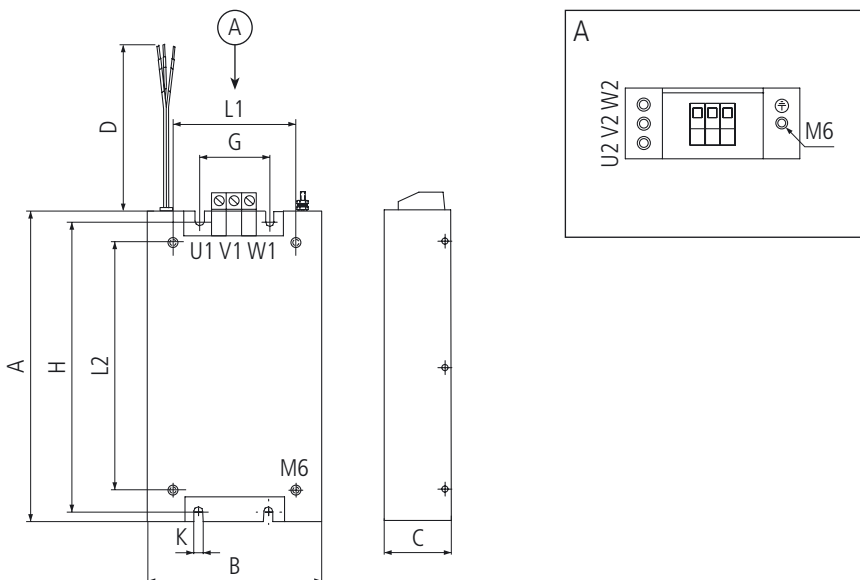

BONFIGLIOLI EMI filter	A [mm]	B [mm]	C [mm]	D [mm]	G [mm]	H [mm]	K [mm]	L1 [mm]	L2 [mm]
FTV018B	315	100	65	300	35	300	6.3	76	270
FTV040B	315	125	65	300	60	300	6.3	125	270

Book type EMI filters



Technical specifications

Mains voltage

3 x 480 VAC

Rated current

7 A ... 130 A

Frequency

up to 60 Hz

Operating and storage temperature

-25 °C ... +80 °C (climate class acc. to CEI 25/80/21)

Type of protection

IP20

Maximum length of motor cables:

ACU 401-01 to ACU 401-15: 25 m class B

ACU 401-18 to ACU 401-25: 50 m class B

ACU 401-27 to ACU 401-39: 10 m class B, 100 m class A group 1

ACU 401-43 to ACU 401-49: 10 m class B, 100 m class A group 1

Note: Overload capacity is 4 times rated current at switch-on; 1.5 times rated current for 1 minute, once per hour.

BONFIGLIOLI Inverter		BONFIGLIOLI EMI filter	Rated current	Leakage current	Power dissipation	Weight
Size	Type		[A]	[mA]	[W]	[kg]
1	ACU 201-01	FTV007A	7		3,8	0,5
	ACU 201-03					
	ACU 201-05					
	ACU 201-07					
	ACU 201-09					
	ACU 401-01					
	ACU 401-03					
	ACU 401-05					
	ACU 401-07					
	ACU 401-09					
	ACU 401-11					
2	ACU 201-11	FTV016A	16	33	6,1	0,8
	ACU 401-12					
	ACU 401-13					
	ACU 401-15					
	ACU 201-13					
3	ACU 201-15	FTV030A	30		11,8	1,2
	ACU 401-18					
	ACU 401-19					
	ACU 401-21					
4	ACU 201-18	FTV055A	55		25,9	2,0
	ACU 201-19					
	ACU 401-22					
5	ACU 201-21	FTV075A	75		32,2	2,7
	ACU 401-23					
6	ACU 201-25	FTV100A	100		34,5	4,3
	ACU 401-27					
	ACU 401-31					
	ACU 401-35					
7	ACU 201-22	FTV130A	130		43,1	4,5
	ACU 401-27					
	ACU 401-37					
	ACU 401-39					
7	ACU 401-43	FTV180A	180	33	58,3	6,0
	ACU 401-45					
	ACU 401-47					
	ACU 401-49					
7	ACU 401-43	FTV250A	250	98	90	12,4
	ACU 401-45					

Book type EMI filters

Dimensions
FTV007A ... FTV180A

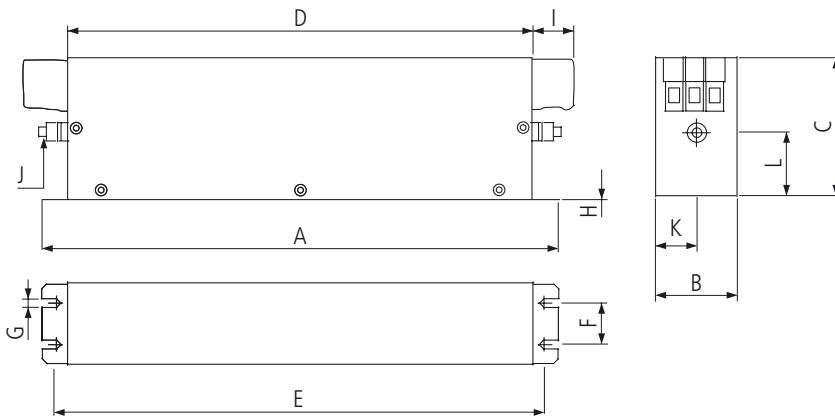

BONFIGLIOLI EMI filter	A [mm]	B [mm]	C [mm]	D [mm]	E [mm]	F [mm]	G [mm]	H [mm]	I [mm]	J [mm]	K [mm]	L [mm]
FTV007A	190	40	70	160	180	20	4.5	1	22	M5	20	29.5
FTV016A	250	45	70	220	235	25	5.4	1	22	M5	22.5	29.5
FTV030A	270	50	85	240	255	30	5.4	1	25	M5	25	39.5
FTV055A	250	85	90	220	235	60	5.4	1	39	M6	42.5	26.5
FTV075A	270	80	135	240	255	60	6.5	1.5	39	M6	40	70.5
FTV100A	270	90	150	240	255	65	6.5	1.5	45	M10	45	64
FTV130A	270	90	150	240	255	65	6.5	1.5	45	M10	45	64
FTV180A	380	120	170	350	365	102	6.5	1.5	49.5	M10	60	47

Dimensions
FTV250A

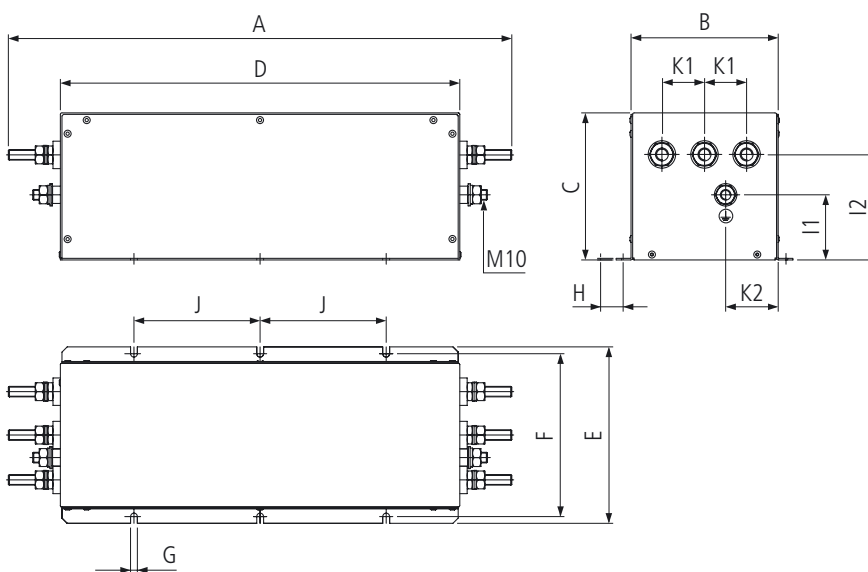

BONFIGLIOLI EMI filter	A [mm]	B [mm]	C [mm]	D [mm]	E [mm]	F [mm]	G [mm]	H [mm]	I1 [mm]	I2 [mm]	J [mm]	K1 [mm]	K2 [mm]
FTV250A	482	140	140	380	168	155	6.5	1.5	62	100	120	40	50

Braking Resistors



When speed of an inverter-controlled ac motor is reduced, the motor acts as a generator, feeding back energy to the frequency inverter. As a result, voltage in the intermediate circuit of the inverter increases. When a specific threshold is exceeded, the energy must flow to an external braking system in order to avoid drive failures. Braking resistors are designed to absorb such energy and to dissipate it into heating. The use of brake resistors allows drives to fulfil the requirements of particularly severe duty cycles, for example those featured by frequent braking, long lasting braking or impulsive braking.

Bonfiglioli Vectron offers a wide range of safe and compact braking resistors with IP20 degree of protection: "BR series".

BR series are designed for panel mounting.

Mostly, they are equipped with built-in thermal protection.

BR models have been thoroughly tested with Bonfiglioli frequency inverters, therefore they can be used together with all Active, Synplus, and VCB models.

Connection diagram

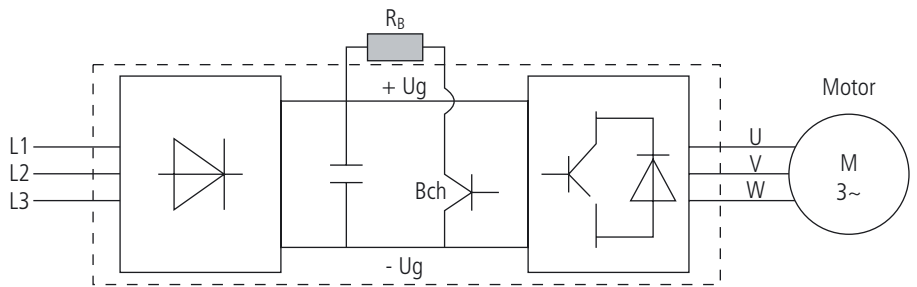

R_B = external braking resistor
Bch = brake chopper integrated in standard ACTIVE inverter

Connection terminals

The Rb1 and Rb2 braking resistor terminals on Active frequency inverters are located on the X2 power output terminal strip. Access to these terminals on size 1 and 2 units is made even easier by the use of disconnectable power terminal strips. Refer to the manual provided with your frequency inverter for further details on materials and connection methods.



**Frequency inverter
(from 0.25 to 4.0 kW)**

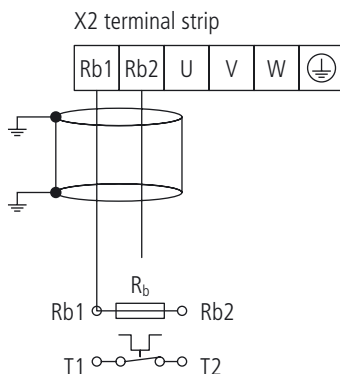

**Frequency inverter
(from 5.5 to 132 kW)**

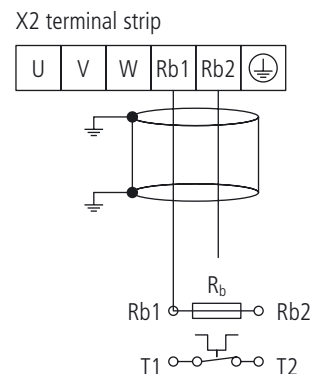

Braking Resistors



Active drive combination chart

These charts show recommended combinations for each model in the Active range, and specify the corresponding duty cycles on the basis of rated drive power. Contact your nearest Bonfiglioli Drive Centre for particularly heavy-duty braking applications or if you need to customise a product.

ACTIVE CUBE Series	kW	Bonfiglioli braking resistor	Resistance Ohm	Continuous rated power	Duty cycle at the drive's rated power
ACU 201-01	0,25	BR 160/100	100	160	64%
ACU 201-03	0,37	BR 160/100	100	160	43%
ACU 201-05	0,55	BR 160/100	100	160	29%
ACU 201-07	0,75	BR 160/100	100	160	21%
ACU 201-09	1,1	BR 160/100	100	160	15%
ACU 201-11	1,5	BR 432/37	37	432	29%
ACU 201-12	2,2	BR 432/37	37	432	20%
ACU 201-15	3	BR 432/37	37	432	14%
ACU 201-18	4	BR 667/24	24	667	17%
ACU 201-19	5,5	BR 667/24	24	667	12%
ACU 201-21	7,5	BR 1333/12	12	1333	18%
ACU 201-22	9,2	BR 1333/12	12	1333	14%
ACU 401-01	0,25	BR 213/300	300	213	85%
ACU 401-03	0,37	BR 213/300	300	213	57%
ACU 401-05	0,55	BR 213/300	300	213	39%
ACU 401-07	0,75	BR 213/300	300	213	28%
ACU 401-09	1,1	BR 213/300	300	213	19%
ACU 401-11	1,5	BR 213/300	300	213	14%
ACU 401-12	1,85	BR 471/136	136	471	25%
ACU 401-13	2,2	BR 471/136	136	471	21%
ACU 401-15	3	BR 471/136	136	471	16%
ACU 401-18	4	BR 696/92	92	696	17%
ACU 401-19	5,5	BR 1330/48	48	1330	24%
ACU 401-21	7,5	BR 1330/48	48	1330	18%
ACU 401-22	9,2	BR 1330/48	48	1330	14%
ACU 401-23	11	BR 2000/32	32	2000	18%
ACU 401-25	15	BR 2000/32	32	2000	13%
ACU 401-27	18,5	BR 4000/16	16	4000	22%
ACU 401-29	22	BR 4000/16	16	4000	18%
ACU 401-31	30	BR 4000/16	16	4000	13%
ACU 401-33	37	BR 8000/7	7,5	8000	22%
ACU 401-35	45	BR 8000/7	7,5	8000	18%
ACU 401-37	55	BR 8000/7	7,5	8000	15%
ACU 401-39	65	BR 8000/7	7,5	8000	12%
ACU 401-43	75	BR8000/7	7,5	8000	11%
ACU 401-45	90	BR8000/7	7,5	8000	9%
ACU 401-47	110	2xBR8000/7	3,75	16000	15%
ACU 401-49	132	2xBR8000/7	3,75	16000	12%

Note:

For further information refer to the Bonfiglioli braking resistor catalogue.



Bonfiglioli is a Partner Worldwide for Power Transmission and Motion Control



The ever-growing export share has led Bonfiglioli into the most far away Countries. With expansion plans entailing a further growth of the sales network Bonfiglioli aims at improving both the competitiveness of its products and the effectiveness of the Customer service. In every market place Bonfiglioli is committed to improve the Customer satisfaction by offering state-of-the-art technology and shorter deliveries. Nowadays branch companies and BEST Partners bearing the Bonfiglioli name are operating in seventeen Countries outside Italy, with sales and service in the other countries managed by appointed dealers. The domestic network is made up of 30 sales office and representatives and 100 dealers operating with their own warehouse and supporting Customers locally. Throughout the World Bonfiglioli's reputed know-how and Service guarantee effective and timely assistance.

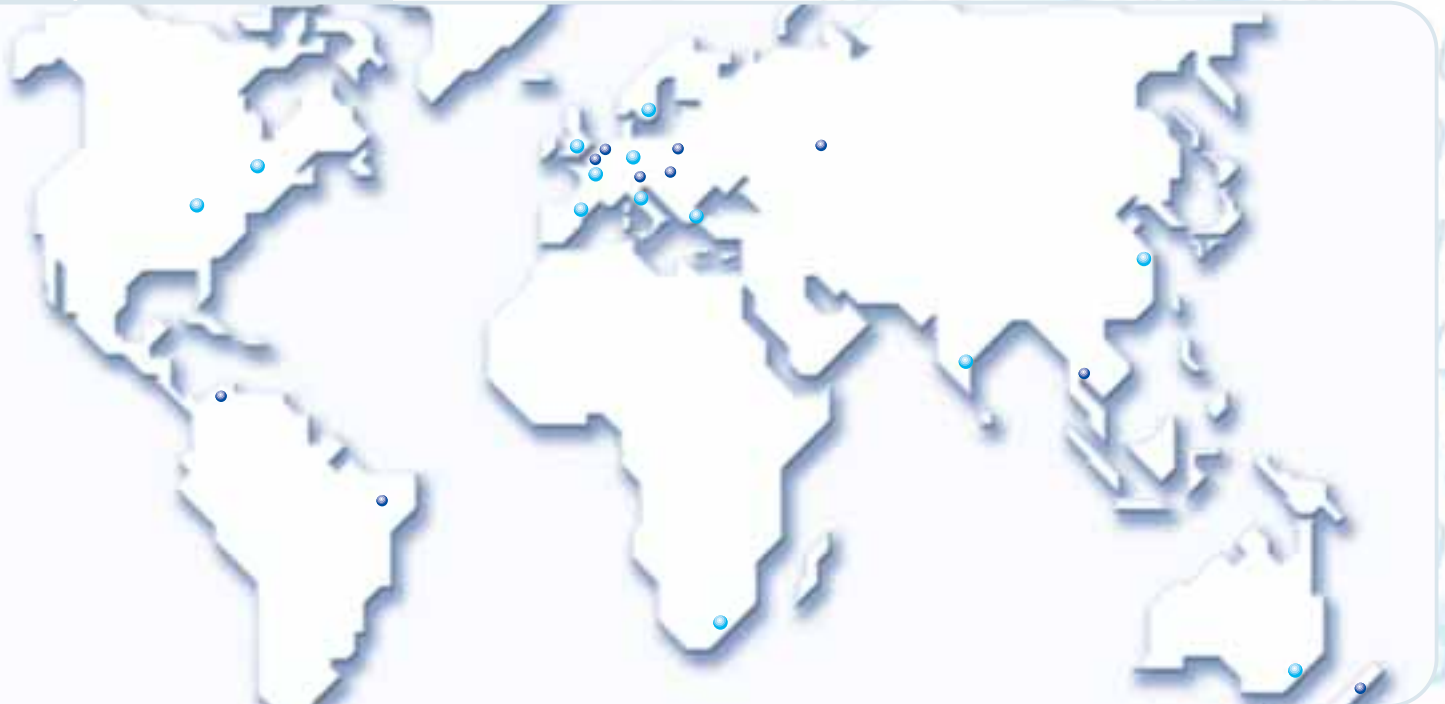

Bonfiglioli Worldwide & BEST Partners

Worldwide

AUSTRALIA

BONFIGLIOLI TRANSMISSION (Aust) Pty Ltd.
2, Cox Place Glendenning NSW 2761, Australia
Locked Bag 1000 Plumpton NSW 2761
Tel. (+61) 2 8811 8000 - Fax (+61) 2 9675 6605
www.bonfiglioli.com.au - sales@bonfiglioli.com.au

AUSTRIA

MOLL MOTOR GmbH
Industriestrasse 8 - 2000 Stockerau
Tel. (+43) 2266 63421+DW - Fax (+43) 6342 180
www.mollmotor.at - office@mollmotor.at

BELGIUM

ESCO TRANSMISSION N.V.S.A.
Culliganlaan 3 - 1831 Machelem Diegem
Tel. (+32) 2 7176460 - Fax (+32) 2 7176461
www.escotransmissions.be - info@escotransmissions.be

BRASIL

ATI BRASIL
Rua Omlio Monteiro Soares, 260 - Vila Fanny - 81030-000
Tel. (+41) 334 2091 - Fax (+41) 332 8669
www.atibrasil.com.br - vendas@atibrasil.com.br

CANADA

BONFIGLIOLI CANADA INC.
2-7941 Jane Street - Concord, Ontario L4K 4L6
Tel. (+1) 905 7384466 - Fax (+1) 905 7389833
www.bonfigliolicanada.com - sales@bonfigliolicanada.com

CHILE

IMATESA S.A.
Santa Rosa 5699 - San Miguel - Santiago
Tel. (+56) 2 5264702 - Fax (+56) 2 5265878
www.imatesa.cl - imatesa@imatesa.cl

CHINA

BONFIGLIOLI DRIVES (SHANGHAI) CO. LTD.
19D, No. 360 Pudong Road (S)
New Shanghai International Tower - 200120 Shanghai - P.R. China
Tel. (+86) 21 69225500 - Fax (+86) 21 69225511
www.bonfiglioli.cn - bds@bonfiglioli.com.cn

FRANCE

BONFIGLIOLI TRANSMISSIONS S.A.
14 Rue Eugène Pottier BP 19
Zone Industrielle de Moimont II - 95670 Marly la Ville
Tel. (+33) 1 34474510 - Fax (+33) 1 34688800
www.bonfiglioli.fr - btff@bonfiglioli.fr

GERMANY

BONFIGLIOLI DEUTSCHLAND GmbH
Sperberweg 12 - 41468 Neuss
Tel. (+49) 02131 2988-0 - Fax (+49) 02131 2988-100
www.bonfiglioli.de - info@bonfiglioli.de

GREAT BRITAIN

BONFIGLIOLI UK Ltd
Industrial Equipment - Unit 3 Colemeadow Road
North Moons Moat - Redditch, Worcestershire B98 9PB
Tel. (+44) 1527 65022 - Fax (+44) 1527 61995
www.bonfiglioli.com - uksales@bonfiglioli-uk.com

Mobile Equipment
5 Grosvenor Grange, Woolston, Warrington - Cheshire WA1 4SF
Tel. (+44) 1925 852667 - Fax (+44) 1925 852668
www.bonfiglioli-uk.com - salesmobile@bonfiglioli-uk.com

GREECE

B.E.S.T. HELLAS S.A.
O.T. 48A T.O. 230 - C.P. 570 22, Industrial Area - Thessaloniki
Tel. (+30) 2310 796456 - Fax (+30) 2310 795903
www.bonfiglioli.gr - info@bonfiglioli.gr

HOLLAND

ELSTO AANDRIJFTECHNIEK
Loosterweg, 7 - 2215 TL Voorhout
Tel. (+31) 252 219 123 - Fax (+31) 252 231 660
www.elsto.nl - info@elsto.nl

HUNGARY

AGISYS AGITATORS & TRANSMISSIONS Ltd
2045 Törökbalint, Tó u.2. Hungary
Tel. (+36) 23 50 11 50 - Fax (+36) 23 50 11 59
www.agisys.hu - info@agisys.hu

INDIA

BONFIGLIOLI TRANSMISSIONS PVT Ltd.
PLOT AC7-AC11 Sidco Industrial Estate - Thirumudivakkam - Chennai 600 044
Tel. +91(0) 44 24781035 / 24781036 / 24781037
Fax +91(0) 44 24780091 / 24781904
www.bonfiglioli.co.in - bonfig@vsnl.com

INDONESIA

PT. ANEKAMAKMUR TEKNIK NUSAJAYA
Pertokoan Glodok Makmur No. 32 - Jakarta Barat
Tel. (+62) 21 624 8828 - Fax (+62) 21 624 2405
www.anekamakmur.com - sales@anekamakmur.com

ITALY

BONFIGLIOLI ITALIA S.p.A.
Via Sandro Pertini lotto 7b - 20080 Carpiano (Milano)
Tel. (+39) 02 985081 - Fax (+39) 02 985085817
www.bonfiglioli.it - customerservice.italia@bonfiglioli.it

NEW ZEALAND

SAECO BEARINGS TRANSMISSION
36 Hastie Avenue, Mangere Po Box 22256, Otahuhu - Auckland
Tel. (+64) 9 634 7540 - Fax (+64) 9 634 7552
mark@saeco.co.nz

POLAND

POLPACK Sp. z o.o. - Ul. Chrobrego 135/137 - 87100 Torun
Tel. (+48) 56 6559235 - 6559236 - Fax (+48) 56 6559238
www.polpack.com.pl - polpack@polpack.com.pl

PORTUGAL

BT BONFITEC Equipamentos Industriais, Lda.
Largo do Colegio de Ermesinde, 70 - Formiga 4445-382 Ermesinde
Tel. (+351) 229759634/5/6 - Fax (+351) 229752211
www.bonfitec.pt - bonfitec@bonfitec.pt

RUSSIA

FAM
57, Maly prospekt, V.O. - 199048, St. Petersburg
Tel. (+7) 812 3319333 - Fax (+7) 812 3271454
www.fam-drive.ru - info@fam-drive.ru

SPAIN

TECNOTRANS BONFIGLIOLI S.A.
Pol. Ind. Zona Franca sector C, calle F, nº6 08040 Barcelona
Tel. (+34) 93 4478400 - Fax (+34) 93 3360402
www.tecnotrans.com - tecnotrans@tecnotrans.com

SOUTH AFRICA

BONFIGLIOLI POWER TRANSMISSION Pty Ltd.
55 Galaxy Avenue, Linbro Business Park - Sandton
Tel. (+27) 11 608 2030 OR - Fax (+27) 11 608 2631
www.bonfiglioli.co.za - bonfigsales@bonfiglioli.co.za

SOUTH KOREA

YOUN HO INDUSTRIAL
Room B1, World Plaza Bldg.
1262 Guro-Dong, Gurd-Gu, Seoul
Tel. (+82) 2 626 43201 - Fax (+82) 2 263 23202
www.younho.com - younho@younho.com

SWEDEN

BONFIGLIOLI SKANDINAVIEN AB
Koppargatan 8 - 234 35 Lomma, Sweden
Tel. (+46) 40418230 - Fax (+46) 40414508
www.bonfiglioli.se - info@bonfiglioli.se

THAILAND

K.P.T MACHINERY (1993) CO.LTD.
259/83 Soi Phiboovnes, Sukhumvit 71 Rd. Phraknong-nur,
Wattana, Bangkok 10110
Tel. (+66) 2 3913030/7111998
Fax (+66) 2 71 12852/3811308/3814905
www.kpt-group.com - sales@kpt-group.com

TURKEY

BONFIGLIOLI TURKIYE
Atatürk Organize Sanayi Bölgesi, 10015 Sk. No: 17, Çiğli - Izmir
Tel. +90 (0) 232 328 22 77 (pbx) - Fax +90 (0) 232 328 04 14
www.bonfiglioli.com.tr - info@bonfiglioli.com.tr

USA

BONFIGLIOLI USA, INC.
3541 Hargrave Drive Hebron, Kentucky 41048
Tel. (+1) 859 334 3333 - Fax (+1) 859 334 8888
www.bonfiglioliusa.com
industrialsales@bonfiglioliusa.com - mobilesales@bonfiglioliusa.com

VENEZUELA

MAICA SOLUCIONES TECNICAS C.A.
Calle 3B - Edif. Comindu - Planta Baja
Local B - La Urbina - Caracas 1070
Tel. (+58) 212 2413570 / 2425268 / 2418263
Fax (+58) 212 2424552 - Tlx 24780 Maica V - maica1@cantv.net

HEADQUARTERS

BONFIGLIOLI RIDUTTORI S.p.A.
Via Giovanni XXIII, 7/A
40012 Lippo di Calderara di Reno
Bologna (ITALY)
Tel. (+39) 051 6473111
Fax (+39) 051 6473126
www.bonfiglioli.com
bonfiglioli@bonfiglioli.com

SPARE PARTS BONFIGLIOLI

B.R.T.
Via Castagnini, 2-4
Z.I. Bargellino - 40012
Calderara di Reno - Bologna (ITALY)
Tel. (+39) 051 727844
Fax (+39) 051 727066
www.brtonfiglioliricambi.it
brt@bonfiglioli.com



Active Cube

www.bonfiglioli.com

