

SINAMICS G120

Standard inverters

0.37 kW to 250 kW (0.5 hp to 400 hp)

4



4/2	SINAMICS G120 standard inverters	4/74	Line-side power components
4/2	Overview	4/74	Line filters
4/4	Benefits	4/77	Line reactors
4/4	Applications	4/81	Recommended line components
4/4	Design	4/83	DC link components
4/9	Configuration	4/83	Braking resistors
4/10	Technical specifications	4/86	Braking Modules
4/12	CU230 Control Units	4/88	Load-side power components
4/12	Overview	4/88	Output reactors
4/12	Selection and ordering data	4/95	Sine-wave filters
4/12	Function	4/102	Supplementary system components
4/13	Design	4/102	Intelligent Operator Panel IOP
4/14	Integration	4/104	Basic Operator Panel BOP
4/17	Technical specifications	4/105	MMC memory card
4/19	CU240 Control Units	4/106	CM240NE chemical industry module
4/19	Overview	4/108	PC Connection Kit -2
4/19	Selection and ordering data	4/108	PC Connection Kit
4/20	Design	4/109	Brake relay
4/22	Integration	4/110	Safe Brake Relay
4/28	Technical specifications	4/111	Adapter for mounting on DIN rails
4/30	PM240 Power Modules	4/111	Shield Connection Kit
	0.37 kW to 250 kW (0.5 hp to 400 hp)	4/112	Shield Connection Kit 1
4/30	Overview	4/112	Shield Connection Kit for CU230P-2 Control Units
4/31	Selection and ordering data		Shield Connection Kit for CU240S Control Units
4/32	Integration	4/113	Spare parts
4/36	Technical specifications	4/113	CU240 Spare Parts Kit
4/42	Characteristic curves	4/113	Replacement door for PM240 frame size FSGX
4/44	Dimensional drawings	4/114	Terminal Cover Kit for frame sizes FSD and FSE
4/50	PM250 Power Modules	4/114	Terminal Cover Kit for frame size FSF
	7.5 kW to 75 kW (10 hp to 100 hp)	4/115	Replacement connector
4/50	Overview	4/116	Replacement fan
4/51	Selection and ordering data		
4/52	Integration		
4/55	Technical specifications		
4/59	Characteristic curves		
4/60	Dimensional drawings		
4/64	PM260 Power Modules		
	11 kW to 55 kW (15 hp to 75 hp)		
4/64	Overview		
4/65	Selection and ordering data		
4/66	Integration		
4/68	Technical specifications		
4/71	Characteristic curves		
4/72	Dimensional drawings		
4/73	Compact inverters		
	0.37 kW to 15 kW (0.5 hp to 20 hp)		
4/73	Overview		
4/73	Selection and ordering data		

SINAMICS G120

Standard inverters 0.37 kW to 250 kW (0.5 hp to 400 hp)

SINAMICS G120 standard inverters

Overview

The SINAMICS G120 frequency inverter is designed to provide precise and cost-effective speed/torque control of AC motors.

With different device versions (frame sizes FSA to FSGX) in a power range from 0.37 kW to 250 kW (0.5 hp to 400 hp), it is suitable for a wide variety of drive solutions.



Examples of SINAMICS G120, frame sizes FSA, FSB and FSC; each with Power Module, Control Unit and Basic Operator Panel



Examples of SINAMICS G120, frame sizes FSD, FSE and FSF; each with Power Module, Control Unit and Basic Operator Panel

SINAMICS G120

Standard inverters 0.37 kW to 250 kW (0.5 hp to 400 hp)

SINAMICS G120 standard inverters

Overview



Examples of SINAMICS G120, frame size FSGX; with Power Module

Modularity

SINAMICS G120 is a modular inverter system comprising a variety of functional units. The main units are:

- the Control Unit (CU)
- the Power Module (PM)

The Control Unit controls and monitors the Power Module and the connected motor using several different control types that can be selected. It supports communication with a local or central control and monitoring devices.

The Power Module supplies the motor in a power range 0.37 kW to 250 kW (0.5 hp to 400 hp). The Power Module is controlled by a microprocessor in the Control Unit. State-of-the-art IGBT technology with pulse-width modulation is used to achieve the highest degree of reliability and flexible motor operation. Comprehensive protection functions provide a high degree of protection for the Power Module and the motor.

Furthermore, a large number of additional components are available, such as:

- Intelligent Operator Panel (IOP) for parameterizing, diagnosing, controlling and copying drive parameters
- Basic Operator Panel (BOP) for parameterizing, diagnosing, controlling and copying drive parameters
- Line filters, Classes A and B
- Line reactors
- Braking resistors
- Sine-wave filters
- Output reactors

Safety Integrated

The SINAMICS G120 standard inverters are available in a number of different versions for safety-related applications. All Power Modules are already designed for Safety Integrated. A Safety Integrated Drive can be created by combining a Power Module with the appropriate Fail-safe Control Unit.

The SINAMICS G120 fail-safe frequency inverter provides four safety functions, certified in accordance with EN 954-1, Category 3 and IEC 61508 SIL 2:

- Safe Torque Off (STO) to protect against active movement of the drive
- Safe Stop 1 (SS1) for continuous monitoring of a safe braking ramp
- Safely Limited Speed (SLS) for protection against dangerous movements when a speed limit is exceeded
- Safe Brake Control (SBC) for controlling motor brakes that are active in the de-energized state, e.g. motor holding brakes

The functions "Safe Stop 1" and "Safely Limited Speed" can both be implemented without having to use a motor sensor or encoder; the implementation cost is minimal. Existing systems in particular can be updated with safety technology without the need to change the motor or mechanical system.

The safety functions "Safely Limited Speed" and "Safe Stop 1" are not certified for pull-through loads as in the case of lifting gear and winders.

Additional information is provided in the part Highlights, section Safety Integrated.

Efficient Infeed Technology

The innovative Efficient Infeed Technology is used in PM250 and PM260 Power Modules. This technology allows the energy produced by motors operating in generator mode connected to standard inverters to be fed back into the supply system. Additional cooling and additional space requirement in the control cabinet can be avoided as components such as braking resistors, brake choppers and line reactors are not required. Further, wiring and engineering costs are significantly reduced. At the same time, considerable savings can be achieved in terms of energy consumption and operating costs.

Additional information is included in the part Highlights, section Efficient Infeed Technology.

Innovative cooling concept and coated electronic modules

The innovative cooling concept and coated electronic modules significantly increase the service life and usage time of the device. These features are based on the following principles:

- The power loss is exclusively dissipated using an external heat sink
- Electronic modules not located in air duct
- Standardized convection cooling of Control Unit
- All cooling air from the fan is directed through the heat sink

STARTER commissioning tool

The STARTER commissioning tool simplifies the commissioning and maintenance of SINAMICS G120 inverters. The operator guidance combined with comprehensive, user-friendly functions for the relevant drive solution allow you to commission the device quickly and easily.

SINAMICS G120

Standard inverters 0.37 kW to 250 kW (0.5 hp to 400 hp)

SINAMICS G120 standard inverters

Benefits

- Modularity ensures flexibility for a drive concept that is fit-for-the-future
 - Modules can be replaced under voltage (hot swapping)
 - Pluggable terminals
 - The modules can be easily replaced, which makes the system extremely service friendly.
- The safety functions make it easier to integrate drives into safety-oriented machines or plants
- Communications-capable via PROFINET or PROFIBUS with PROFIdrive Profile 4.0
 - Reduced number of interfaces
 - Plantwide engineering
 - Easy to handle
- The innovative circuit design (bidirectional input rectifier with "pared-down" DC link) allows the kinetic energy of a load to be fed back into the supply system when Power Modules PM250 and PM260 are used. This feedback capability provides enormous potential for savings because generated energy no longer has to be converted into heat in a braking resistor
- Innovative SiC semiconductor technology ensures that when a PM260 Power Module is used, the inverter is more compact than a comparable standard converter with an optional sine-wave filter for the same power rating
- An innovative cooling concept and coated electronic modules increase robustness and service life
 - External heatsink
 - Electronic components are not located in air duct
 - Control Unit that is completely cooled by convection
 - Additional coating of the most important components
- Simple unit replacement and quick copying of parameters using the optional Basic Operator Panel or the optional MMC memory card
- Quiet motor operation as a result of the high pulse frequency
- Compact, space-saving design
- Software parameters for simple adaptation to 50 Hz or 60 Hz motors (IEC or NEMA motors)
- 2-/3-wire control (static/pulsed signals) for universal control via digital inputs (only CU240 Control Units)
- Engineering and commissioning with uniform engineering tools such as SIZER, STARTER, and Drive ES: ensure fast engineering and easy commissioning – STARTER is integrated in STEP 7 with Drive ES Basic with all the advantages of central data storage and totally integrated communication
- Certified worldwide for compliance with CE, UL, cUL, c-tick and Safety Integrated according to IEC 61508 SIL 2

Applications

SINAMICS G120 is ideally suited

- as a universal drive in all industrial and commercial applications
- e.g. in the automotive, textile, printing and chemical industries
- for higher-level applications, e.g. in conveyor systems

Design

SINAMICS G120 standard inverters are modular frequency inverters for standard drives. Each SINAMICS G120 comprises two operative units – the Power Module and Control Unit. Each Control Unit can be combined with each Power Module.

Guidelines for module selection

The procedure to select a complete SINAMICS G120 frequency inverter should be as follows:

1. Select a suitable Control Unit (depending on the required communication, hardware and software version and safety functionality)
2. Select a suitable Power Module (depending on the power and technology required)
3. Select the optional and additional components. There are a large number of components for expanding the system (e.g. line-side power components, DC link components, load-side power components, and supplementary system components). However, it should be noted that not all of the components are required for all of the Power Modules (example: Braking resistors are not required for the PM250 and PM260 Power Modules!). The precise data is provided in the technical specifications tables of the particular components.

Control Units

The Control Unit performs closed-loop control functions for the inverter. In addition to the closed-loop control, it has additional functions that can be adapted to the particular application through parameterization.

Two series of Control Units are available for SINAMICS G120 corresponding to their software packages (CU230 and CU240). Each Control Unit comprises a defined I/O quantity structure, a special fieldbus interface and possible additional safety functions. The following Control Units and accessories are available for standard SINAMICS G120 inverters:

CU230 Control Units

The CU230P-2 Control Units have been specifically designed for pump, fan and compressor applications. The following three versions are available:

- CU230P-2 HVAC
- CU230P-2 DP
- CU230P-2 CAN

CU240 Control Units

Several Control Units are available in different versions:

- CU240E
- CU240S
- CU240S DP
- CU240S DP-F
- CU240S PN
- CU240S PN-F

Design**Power Modules**

The following Power Modules are available for the SINAMICS G120 standard inverters:

PM240 Power Modules

PM240 Power Modules (0.37 kW to 250 kW / 0.5 hp to 400 hp) feature an integrated brake chopper (for frame size FSGX external) and are designed for drives without energy recovery capability. Generator energy produced during braking is converted to heat via externally connected braking resistors.

PM250 Power Modules

PM250 Power Modules (7.5 kW to 90 kW / 10 hp to 125 hp) have an innovative circuit design which allows line-commutated energy recovery back into the line supply. This innovative circuit permits generator energy to be fed back into the supply system and therefore saves energy.

PM260 Power Modules

PM260 Power Modules (11 kW to 55 kW / 15 hp to 75 hp) also have an innovative circuit design which allows line-commutated energy recovery back into the line supply. This innovative circuit permits generator energy to be fed back into the supply system and therefore saves energy. The PM260 Power Modules also have an integrated sine-wave filter that limits the rate of rise of voltage and the capacitive charging/discharging currents usually associated with inverter operation.

Line-side power components

The following line-side power components are available for SINAMICS G120 standard inverters:

Line filters

With one of the additional line filters, the Power Module reaches a higher radio interference class.

Line reactors (for PM240 Power Modules only)

A line reactor reduces the system perturbations caused by harmonics. This particularly applies in the case of weak line supplies (line supply short-circuit power $u_K > 1\%$).

Recommended line components

This is a recommendation for additional line-side components, such as fuses and circuit-breakers (line-side components must be dimensioned in accordance with IEC standards). Additional information about the listed fuses and circuit breakers can be found in Catalogs LV 1 and LV 1 T.

DC link components

The following DC link components are available for the SINAMICS G120 standard inverters:

Braking Modules (only for PM240 Power Modules, frame size FSGX)

A Braking Module and the matching external braking resistor are required to bring drives with a PM240 Power Module, frame size FSGX to a controlled standstill in the event of a power failure (e.g. emergency retraction or EMERGENCY STOP Category 1) or limit the DC link voltage during a short period of generator operation. The Braking Module includes the power electronics and the associated control circuit.

Braking resistors (for PM240 Power Modules only)

Excess energy in the DC link is dissipated in the braking resistor. The braking resistors are designed for use with PM240 Power Modules. They are equipped with an integrated brake chopper (electronic switch). There is an optional plug-in Braking Module for frame size FSGX.

Load-side power components

The following load-side power components are available for the SINAMICS G120 standard inverters. This means that during operation with output reactors or sine-wave filters, longer, shielded motor cables are possible and the motor service life can be extended:

Output reactors (for PM240 and PM250 Power Modules only)

Output reactors reduce the voltage stress on the motor windings. At the same time, the capacitive charging/discharging currents, which place an additional load on the power unit when long motor cables are used, are reduced.

Sine-wave filter (not for PM260 Power Modules)

The sine-wave filter limits the rate of rise of voltage and the capacitive charging/discharging currents that usually occur with inverter operation. An output reactor is not required.

SINAMICS G120

Standard inverters 0.37 kW to 250 kW (0.5 hp to 400 hp)

SINAMICS G120 standard inverters

Design

Power and DC link components which are optionally available depending on the Power Module used

The following line-side power components, DC link components and load-side power components are optionally available in the appropriate frames sizes for the Power Modules:

	Frame size						
	FSA	FSB	FSC	FSD	FSE	FSF	FSGX
PM240 Power Module with integrated brake chopper							without integrated brake chopper
Available frame sizes	✓	✓	✓	✓	✓	✓	✓
Line-side power components							
Line filter, class A	U	F	F	F	F	F/S ³⁾	S ³⁾
Line filter, class B	U	U	U	–	–	–	–
Line reactor	U	U	U	U	U	S	S
DC link components							
Braking resistor	U	U	S	S	S	S	S
Braking Module	–	–	–	–	–	–	I (Option)
Load-side power components							
Output reactor	U	U	U	S	S	S	S
Sine-wave filter	U	U	U	S	S	S	S
PM250 Power Module with line-commutated energy recovery							
Available frame sizes	–	–	✓	✓	✓	✓	–
Line-side power components							
Line filter, class A	–	–	I	F	F	F	–
Line filter, class B	–	–	U	–	–	–	–
Line reactor ¹⁾	–	–	– ¹⁾	– ¹⁾	– ¹⁾	– ¹⁾	–
DC link components							
Braking resistor ²⁾	–	–	– ²⁾	– ²⁾	– ²⁾	– ²⁾	–
Load-side power components							
Output reactor	–	–	U	S	S	S	–
Sine-wave filter	–	–	U	S	S	S	–
PM260 Power Module with line-commutated energy recovery and integrated sine-wave filter							
Available frame sizes	–	–	–	✓	–	✓	–
Line-side power components							
Line filter, class A	–	–	–	F	–	F	–
Line filter, class B	–	–	–	–	–	–	–
Line reactor ¹⁾	–	–	–	– ¹⁾	–	– ¹⁾	–
DC link components							
Braking resistor ²⁾	–	–	–	– ²⁾	–	– ²⁾	–
Load-side power components							
Output reactor	–	–	–	–	–	–	–
Sine-wave filter	–	–	–	I	–	I	–

U = Base component

S = Lateral mounting

I = Integrated

– = Not possible

F = Power Modules available with and without integrated class A filter

¹⁾ A line reactor is not required and must not be used in conjunction with a PM250 or PM260 Power Module.

²⁾ Line-commutated energy recovery is possible in conjunction with a PM250 or PM260 Power Module. A braking resistor cannot be connected and is not necessary.

³⁾ PM240 FSF Power Modules, from 110 kW (150 hp) and higher and FSGX are only available without an integrated class A filter. An optional class A line filter for side mounting is available instead.

SINAMICS G120

Standard inverters 0.37 kW to 250 kW (0.5 hp to 400 hp)

SINAMICS G120 standard inverters

Design

General design information

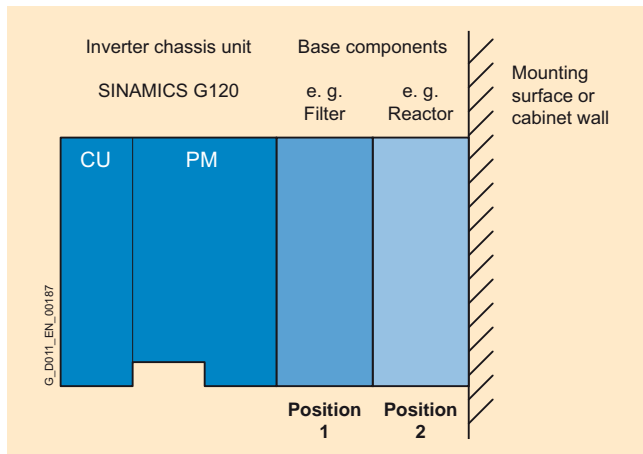

Frequency inverters comprising a Power Module (PM) and a Control Unit (CU) and two base components at position 1 and position 2 (side view)

- A maximum of two base components plus inverter are possible.
- The line filter has to be mounted directly below the frequency inverter (position 1).
- With lateral mounting, the line-side components have to be mounted on the left side of the frequency inverter and the load-side components on the right side.
- Braking resistors have to be mounted directly on the control cabinet wall due to heating issues.

Recommended installation combinations of the inverter and optional power and DC link components

Power Modules Frame size	Base		Lateral mounting	
	Position 1	Position 2	left of the inverter (for line-side power components)	right of the inverter (for load-side power components and DC link components)
FSA and FSB	Line filter	Line reactor	–	Output reactor or sine-wave filter and/or braking resistor
	Line filter or line reactor	Output reactor or sine-wave filter	–	Braking resistor
	Line filter or line reactor	Braking resistor	–	–
	Line filter or line reactor or braking resistor	–	–	–
FSC	Line filter	Line reactor	–	Output reactor or sine-wave filter and/or braking resistor
	Line filter or line reactor	Output reactor or sine-wave filter	–	Braking resistor
FSD and FSE	Line reactor	–	Line filter	Output reactor or sine-wave filter and/or braking resistor
FSF	–	–	Line filter and/or line reactor	Output reactor or sine-wave filter and/or braking resistor
FSGX	–	–	Line filter and/or line reactor	Output reactor or sine-wave filter and/or braking resistor

SINAMICS G120

Standard inverters 0.37 kW to 250 kW (0.5 hp to 400 hp)

SINAMICS G120 standard inverters

Design

Maximum permissible cable lengths from the motor to the inverter when using output reactors or sine-wave filters depending on the voltage range and the Power Module being used

The following load-side power components in the appropriate frame sizes are optionally available for the Power Modules and result in the following maximum cable lengths:

	Maximum permissible motor cable lengths (shielded/unshielded) in m						
	Frame sizes						
	FSA	FSB	FSC	FSD	FSE	FSF	FSGX
PM240 Power Module with integrated brake chopper							without integrated brake chopper
Available frame sizes	✓	✓	✓	✓	✓	✓	✓
Without output reactor/sine-wave filter	50/100	50/100	50/100	50/100	100/100	150/150	300/450
With optional output reactor							
• at 380 V (– 10 %) to 400 V 3 AC	150/225	150/225	150/225	200/300	200/300	200/300	300/450
• at 401 V to 480 V (+ 10 %) 3 AC	100/150	100/150	100/150	200/300	200/300	200/300	300/450
With optional sine-wave filter							
• at 380 V (– 10 %) to 400 V 3 AC	200/300	200/300	200/300	200/300	200/300	200/300	300/450
• at 401 V to 480 V (+ 10 %) 3 AC	200/300	200/300	200/300	200/300	200/300	200/300	300/450
PM250 Power Module with line-commutated energy recovery							
Available frame sizes	–	–	✓	✓	✓	✓	–
Without output reactor/sine-wave filter	–	–	50/100	50/100	50/100	50/100	–
With optional output reactor							
• at 380 V (– 10 %) to 400 V 3 AC	–	–	150/225	200/300	200/300	200/300	–
• at 401 V to 480 V (+ 10 %) 3 AC	–	–	100/150	200/300	200/300	200/300	–
With optional sine-wave filter							
• at 380 V (– 10 %) to 400 V 3 AC	–	–	200/300	200/300	200/300	200/300	–
• at 401 V to 480 V (+ 10 %) 3 AC	–	–	200/300	200/300	200/300	200/300	–
PM260 Power Module with line-commutated energy recovery and integrated sine-wave filter							
Available frame sizes	–	–	–	✓	–	✓	–
With integrated sine-wave filter							
• at 500 V to 690 V 3 AC (± 10 %)	–	–	–	200/300	–	200/300	–

Design**Supplementary system components**

The following supplementary system components are available for the SINAMICS G120 standard inverters:

Intelligent Operator Panel IOP

The IOP supports both entry-level personnel and drive experts. Thanks to the large plain text display, the menu prompting and the Application Wizards, it is easy to commission, diagnose and locally control standard drives.

Operator Panel BOP (not for CU230P-2 Control Units)

The Basic Operator Panel BOP can be plugged onto the Control Unit and can be used to commission drives, monitor drives in operation and input individual parameter settings. The BOP also provides a function to quickly copy parameters.

MMC memory card (not for CU240E Control Units)

The parameter settings for an inverter can be stored on the MMC memory card. When service is required, e.g. after the inverter has been replaced and the data have been downloaded from the memory card the drive system is immediately ready for use again. The associated slot is located on the top of the Control Unit.

CM240NE chemical industry module

Inverters for 400 V / 500 V and 690 V are required in the chemical industry that meet the special demands and requirements of this industry sector. The essential requirements and demands of the chemical industry are fulfilled using the SINAMICS G120 series of inverters supplemented by the CM240NE chemical industry module (with ATEX-certified PTC evaluation and a NAMUR terminal strip).

PC Inverter Connection Kit

For controlling and commissioning an inverter directly from a PC if the appropriate software (STARTER commissioning tool) has been installed.

The STARTER commissioning tool on DVD is included in the PC Inverter Connection Kit.

Brake Relay

The Brake Relay allows the Power Module to be connected to an electromechanical motor brake, thereby allowing the motor brake to be driven directly by the Control Unit.

Safe Brake Relay

The Safe Brake Relay allows the Power Module to be connected to an electromechanical motor brake, allowing the brake to be directly and safely controlled from the Control Unit in accordance with EN 954-1 Category 3 and IEC 61508 SIL 2.

Adapter for mounting on DIN rails

The adapter for mounting on DIN rails can be used to mount inverters of the sizes FSA and FSB on DIN mounting rails (2 units with a center-to-center distance of 100 mm).

Shield Connection Kit

The Shield Connection Kit makes it easier to connect the shields of supply and control cables, offers mechanical strain relief and thus ensures optimum EMC performance.

Shield Connection Kit for CU240S and CU230P-2

The Shield Connection Kit offers optimum shield connection and strain relief for all signal and communication cables. It includes a matching shield bonding plate and all of the necessary connecting and retaining elements for mounting.

Spare partsSpare Parts Kit for CU240

The kit includes a replacement cover for the terminals, a suitable shield bar for the CU240E Control Unit including screws, replacement connector for the CU240S Control Unit, protective element of the MMC card slot and screws to attach the shield bonding plate of the CU240S Control Unit.

Terminal Cover Kit

The kit includes a replacement cover for the terminals. The kit can be ordered for PM240 Power Modules, frame sizes FSD, FSE and FSF, as well as for the PM260, frame size FSF.

PM260 replacement connector

This spare part includes a connector for the input and output sides for the PM260 Power Module, frame size FSD.

SINAMICS G120 PM240 FSGX replacement door

A complete replacement door can be ordered for the PM240 Power Module, frame size FSGX.

Replacement fan

The Power Module fans are designed for extra long service life. Replacement fans can be ordered for special applications.

Configuration

The following electronic configuring and engineering tools are available for the SINAMICS G120 standard inverters:

Selection guide, SD Configurator

More than 100000 products with approximately 5 million possible product versions from the area of drive technology are listed in the interactive Catalog CA 01 – the Offline Mall from Siemens IA&DT. In order to make it easier to select the optimum motor and/or inverter from the wide range of Standard Drives, the SD Configurator was developed, which is integrated as "Selection guide" in this catalog on the DVD together with the selection and engineering tools.

Online SD Configurator

In addition, the SD Configurator can be used in the Internet without requiring any installation. The SD Configurator can be found in the Siemens Mall under the following address:

<http://www.siemens.com/dt-configurator>

SIZER configuration tool

The SIZER PC tool makes it easy to configure the SINAMICS and MICROMASTER 4 drive family. It provides support when selecting the hardware and firmware components necessary to implement a drive task. SIZER supports the configuration of the complete drive system, from simple single-motor drives up to complex multi-axis applications.

STARTER commissioning tool

The STARTER commissioning tool is used to commission, optimize and diagnose drives in a menu-prompted fashion. In addition to SINAMICS drives, STARTER is also suitable for MICROMASTER 4 units and the frequency converters for the distributed I/O SIMATIC ET 200S FC and SIMATIC ET 200pro FC.

Drive ES engineering system

Drive ES is the engineering system used to integrate the communication, configuration and data management functions of Siemens drive technology into the SIMATIC automation world easily, efficiently and cost-effectively. The STEP 7 Manager user interface forms the basis. Various software packages are available for SINAMICS:

Drive ES Basic, Drive ES SIMATIC and Drive ES PCS 7.

SINAMICS G120

Standard inverters 0.37 kW to 250 kW (0.5 hp to 400 hp)

SINAMICS G120 standard inverters

Technical specifications

Unless explicitly specified otherwise, the following technical specifications are valid for all the following components of the SINAMICS G120 standard inverters.

Mechanical specifications	
Vibratory load	
<ul style="list-style-type: none"> Transport ¹⁾ acc. to EN 60721-3-2 <ul style="list-style-type: none"> All units and components except frame size FSGX Units with frame size FSGX Operation <ul style="list-style-type: none"> Test values acc. to EN 60068-2-6 	Class 2M3 Class 2M2 Test Fc: 10 ... 58 Hz: Constant deflection 0.075 mm 58 ... 150 Hz: Constant acceleration = 9.81 m/s ² (1 × g)
Shock load	
<ul style="list-style-type: none"> Transport ¹⁾ acc. to EN 60721-3-2 <ul style="list-style-type: none"> All units and components except frame size FSGX Units with frame size FSGX Operation <ul style="list-style-type: none"> Test values acc. to EN 60068-2-27 Frame sizes FSA to FSC Frame sizes FSD to FSF Frame size FSGX 	Class 2M3 Class 2M2 Test Ea: 147 m/s ² (15 × g)/11 ms 49 m/s ² (5 × g)/30 ms 98 m/s ² (10 × g)/20 ms
Ambient conditions	
Protection class acc. to EN 61800-5-1	Class I (with protective conductor system) and Class III (PELV)
Touch protection acc. to EN 61800-5-1	For the intended purpose
Permissible ambient and coolant temperature (air) during operation for line-side power components and Power Modules	
<ul style="list-style-type: none"> High overload (HO) Light overload (LO) 	0 ... 50 °C (32 ... 122 °F) without derating (for PM240, frame size FSGX: 0 ... 40 °C), > 50 ... 60 °C see derating characteristics 0 ... 40 °C (32 ... 104 °F) without derating (for PM240, frame size FSGX: 0 ... 40 °C), > 40 ... 60 °C see derating characteristics
Permissible ambient and coolant temperature (air) during operation for Control Units, additional system components and DC-link components	-10 ... +50 °C (14 ... 122 °F) with CU240S DP-F: 0 ... 45 °C with CU240S PN-F: 0 ... 40 °C with IOP: 0 ... 50 °C up to 2000 m above sea level
Climatic ambient conditions	
<ul style="list-style-type: none"> Storage ¹⁾ acc. to EN 60721-3-1 Transport ¹⁾ acc. to EN 60721-3-2 Operation acc. to EN 60721-3-3 	Class 1K3 temperature -25 ... +55 °C Class 2K4 temperature -40 ... +70 °C max. humidity 95 % at 40 °C Class 3K5 ⁴⁾ Condensation, splashwater and ice formation not permitted (EN 60204, Part 1)

¹⁾ In transport packaging.

²⁾ Unfiltered inverters can be used in industrial environments as long as they are part of a system that contains line filters on the higher-level infeed side. As a consequence, a PDS (Power Drive System) can be installed according to C3.

Ambient conditions (continued)

Environmental class/harmful chemical substances	
<ul style="list-style-type: none"> Storage ¹⁾ acc. to EN 60721-3-1 Transport ¹⁾ acc. to EN 60721-3-2 Operation acc. to EN 60721-3-3 	Class 1C2 Class 2C2 Class 3C2
Organic/biological influences	
<ul style="list-style-type: none"> Storage ¹⁾ acc. to EN 60721-3-1 Transport ¹⁾ acc. to EN 60721-3-2 Operation acc. to EN 60721-3-3 	Class 1B1 Class 2B1 Class 3B1
Degree of pollution acc. to EN 61800-5-1	2
Certification for fail-safe versions	
Applies to CU240 DP-F and CU240 PN-F Control Units. The values include Control Unit, Power Module and Safe Brake Relay.	
<ul style="list-style-type: none"> Category acc. to EN 954-1 SIL Cl acc. to IEC 61508 PL acc. to ISO 13849 PFH_D T1 	3 2 Available soon 5 × 10 ⁻⁸ 10 Years
Standards	
Standards conformance	UL, cUL, CE, c-tick
CE mark	According to Low-Voltage Directive 73/23/EEC and Machinery Directive 98/37/EC
EMC Directive acc. to EN 61800-3	
<ul style="list-style-type: none"> Frame sizes FSA to FSGX without integrated line filter class A Frame sizes FSB to FSF with integrated line filter class A Frame size FSA without integrated line filter and with additional line filter class A Frame size FSA with additional line filter class A and with additional line filter class B Frame sizes FSB and FSC with additional line filter class A and with additional line filter class B 	Category C3 ²⁾ Category C2 ³⁾ (corresponds to class A acc. to EN 55011 for conducted interference emission) Category C2 ³⁾ (corresponds to class A acc. to EN 55011 for conducted interference emission) Category C2 ³⁾ (corresponds to class B acc. to EN 55011 for conducted interference emission) Category C2 ³⁾ (corresponds to class B acc. to EN 55011 for conducted interference emission)
<p>Note: The EMC product standard EN 61800-3 does not apply directly to a frequency inverter but to a PDS (Power Drive System), which comprises the complete circuitry, motor and cables in addition to the frequency inverters. The frequency inverters on their own do not generally require identification according to the EMC Directive.</p>	

³⁾ With shielded motor cable up to 25 m.

⁴⁾ For Intelligent Operator Panel IOP, class 3K3.

Technical specifications

Compliance with standards

CE mark



The SINAMICS G120 inverters meet the requirements of the Low-Voltage Directive 73/23/EEC.

Low-Voltage Directive

The inverters comply with the following standards listed in the official journal of the EU:

- EN 60204
Safety of Machinery, electrical equipment of machines
- EN 61800-5-1
Electrical power drive systems with variable speed – Part 5-1: Requirements regarding safety – electrical, thermal, and energy requirements

UL listing



Inverter devices in UL category NMMS certified to UL and cUL, in compliance with UL508C. UL list numbers E121068 and E192450.

For use in environments with pollution degree 2.

Also see the Internet under <http://www.ul.com>

Machinery Directive

The inverters are suitable for installation in machines. Compliance with the Machinery Directive 98/37/EC requires a separate certificate of conformity. This must be provided by the plant construction company or the organization marketing the machine.

EMC Directive

- EN 61800-3
Variable-speed electric drives
Part 3: EMC product standard including specific test methods

The EMC product standard EN 61800-3 has been valid for electric drive systems since 07/01/2005. The transition period for the predecessor standard EN 61800-3/A11 from February 2001 ended on October 1, 2007. The following information applies to SINAMICS G120 frequency inverters from Siemens:

- The EMC product standard EN 61800-3 does not apply directly to a frequency inverter but to a PDS (Power Drive System), which comprises the complete circuitry, motor and cables in addition to the inverter.
- Frequency inverters are normally only supplied to experts for installation in machines or systems. A frequency inverter must, therefore, only be considered as a component which, on its own, is not subject to the EMC product standard EN 61800-3. The inverter's operating manual, however, specifies the conditions regarding compliance with the product standard if the frequency inverter is expanded to become a PDS. For a PDS, the EMC Directive in the EU is complied with by observing the product standard EN 61800-3 for variable-speed electric drive systems. The frequency inverters on their own do not generally require identification according to the EMC Directive.
- In the Standard EN 61800-3 from July 2005, a distinction is no longer made between "general availability" and "restricted availability". Instead, different categories C1 to C4 have been defined in accordance with the environment of the PDS at the operating location:

- **Category C1:** Drive systems for rated voltages < 1000 V for use in the first environment
- **Category C2:** Stationary drive systems not connected by means of a plug connector for rated voltages < 1000 V. When used in the first environment, the system must be installed and commissioned by personnel familiar with EMC requirements. A warning note is required.
- **Category C3:** Drive systems for rated voltages < 1000 V for exclusive use in the second environment. A warning note is required.
- **Category C4:** Drive systems for rated voltages \geq 1000 V or for rated currents \geq 400 A or for use in complex systems in the second environment. An EMC plan must be generated.
- The EMC product standard EN 61800-3 also defines limit values for conducted interference and radiated interference for the so-called "second environment" (= industrial power supply systems that do not supply households). These limit values are below the limit values of filter class A to EN 55011. Unfiltered inverters can be used in industrial environments as long as they are part of a system that contains line filters on the higher-level infeed side.
- With SINAMICS G120, Power Drive Systems (PDS) that fulfill the EMC product standard EN 61800-3 can be configured when observing the installation instructions in the product documentation.
- A differentiation must be made between the product standards for electrical drive systems (PDS) of the range of standards EN 61800 (of which Part 3 covers EMC topics) and the product standards for the devices/systems/machines, etc. This will probably not result in any changes in the practical use of frequency inverters. Since frequency inverters are always part of a PDS and these are part of a machine, the machine manufacturer must observe various standards depending on their type and environment (e.g. EN 61000-3-2 for line harmonics and EN 55011 for radio interference). The product standard for PDS on its own is, therefore, either insufficient or irrelevant.
- With respect to the compliance with limits for line supply harmonics, the EMC product standard EN 61800-3 for PDS refers to compliance with the EN 61000-3-2 and EN 61000-3-12 standards.
- Regardless of the configuration with SINAMICS G120 and its components, the machine construction company (OEM) can also apply other measures to ensure that the machine complies with the EU EMC Directive. The EU EMC Directive is generally fulfilled when the relevant EMC product standards are observed. If they are not available, the generic standards (e.g. DIN EN 61000-x-x) can be used instead. It is important that the conducted and emitted interference at the line connection point and outside the machine remain below the relevant limit values. Any suitable technical measures can be applied to ensure this.

SEMI F47

SEMI F47 is an industry standard relating to the immunity to voltage dips. This includes the requirement that industrial equipment must be able to tolerate defined dips or drops of the line supply voltage. As a result, industrial equipment that fulfills this standard is more reliable and productive. In the SINAMICS G120 product family, the PM240 and PM250 Power Modules fulfill the latest SEMI F47-0706 standard. In the case of a voltage dip, defined in accordance with SEMI F47-0706, these drives either continue to supply a defined output current, or using an automatic restart function, continue to operate as expected.

SINAMICS G120

Standard inverters 0.37 kW to 250 kW (0.5 hp to 400 hp)

CU230 Control Units

Overview



Example: CU230P-2 HVAC Control Unit with Intelligent Operator Panel IOP on the PM240 Power Module, frame size FSC

The CU230P-2 Control Units are especially suitable for drives with integrated technological functions for pump, fan and compressor applications. The I/O interface, the fieldbus interfaces and the additional software functions optimally support these applications. The integration of technological functions is a significant differentiating feature to the other Control Units of the SINAMICS G120 drive family.

4

Selection and ordering data

Communication	Digital inputs	Digital outputs	Analog inputs	Analog outputs	Designation		Control Unit Order No.
Standard							
RS485/USS; Modbus RTU	6	3	4	2	CU230P-2 HVAC	new	6SL3243-0BA30-1HA0
PROFIBUS DP	6	3	4	2	CU230P-2 DP	new	6SL3243-0BA30-1PA0
CANopen	6	3	4	2	CU230P-2 CAN	new	6SL3243-0BA30-1CA0

Function

Closed-loop control

- Linear and square torque characteristics for fluid flow and positive displacement machines
- ECO mode for additional energy saving
- Vector control without encoder for sophisticated control tasks

Connections

- Two analog inputs (current/voltage can be selected) to directly connect pressure/level sensors
- Two additional analog inputs to connect NI1000/PT1000 temperature sensors
- Direct control of valves and flaps using two 230 V relays

Interfaces

- PROFIBUS, USS, CANopen and Modbus RTU communication

Software functions

- Automatic restart function after power failure
- Flying restart
- Kinetic buffering ($V_{dc \min}$ control)
- PID controller for temperature, pressure, air quality, level
- Energy saving using the "hibernation mode"
- Load check function to monitor belts and flow
- Real time clock with three time generators

IOP wizards for special applications such as e.g.

- Pumps: Positive displacement (constant load torque) and centrifugal pumps (square load torque) with and without PID controller
- Fans: Radial and axial fans (square load torque) with and without PID controller
- Compressors: Positive displacement (constant load torque) and fluid flow machines (square load torque) with and without PID controller

SINAMICS G120

Standard inverters 0.37 kW to 250 kW (0.5 hp to 400 hp)

CU230 Control Units

Design

CU230P-2 HVAC, CU230P-2 DP, CU230P-2 CAN Control Units



Example: CU230P-2 DP Control Unit with open terminal covers

Terminal No.	Signal	Features
Digital inputs (DI) – Standard		
69	DI Com	Reference potential for digital inputs
5 ... 8, 16.17	DI0 ... DI5	Freely programmable isolated, inputs in compliance with IEC 61131-2
Digital outputs (DO)		
18	DO0, NC	Relay output 1 NC contact (2 A, 230 V AC)
19	DO0, NO	Relay output 1 NO contact (2 A, 230 V AC)
20	DO0, COM	Relay output 1 Common contact (2 A, 230 V AC)
21	DO1, NO	Relay output 2 NO contact (0.5 A, 30 V DC)
22	DO1, COM	Relay output 2 Common contact (0.5 A, 30 V DC)
23	DO2, NC	Relay output 3 NC contact (2 A, 230 V AC)
24	DO2, NO	Relay output 3 NO contact (2 A, 230 V AC)
25	DO2, COM	Relay output 3 Common contact (2 A, 230 V AC)

Terminal No.	Signal	Features
Analog inputs (AI)		
3	AI0+	Differential input, switchable between current, voltage Value range: 0 ... 10 V, –10 ... +10 V, 0/2 ... 10 V, 0/4 ... 20 mA
4	AI0-	
10	AI1+	Differential input, switchable between current, voltage Value range: 0 ... 10 V, –10 ... +10 V, 0/2 ... 10 V, 0/4 ... 20 mA
11	AI1-	
50	AI2+/NI1000	Non-isolated input, switchable between current, temperature sensors, type PT1000, NI1000 Value range: 0/4 ... 20 mA, PT1000 –50 ... +250 °C; NI1000 –50 ... +150 °C
51	GND	Reference potential of the AI2/internal electronics ground
52	AI3+/NI1000	Non-isolated input for temperature sensors, Type PT1000, NI1000 Value range: PT1000 –50 ... +250 °C; NI1000 –50 ... +150 °C
53	GND	Reference potential of the AI3/internal electronics ground
Analog outputs (AO)		
12	AO0+	Non-isolated output Freely programmable Value range: 0 ... 10 V; 0/4 ... 20 mA
13	AO GND	Reference potential of the AO0/internal electronics ground
26	AO1+	Non-isolated output Freely programmable Value range: 0 ... 10 V; 0/4 ... 20 mA
27	AO GND	Reference potential of the AO1/internal electronics ground
Motor temperature sensor interface		
14	T1 motor	Positive input for motor temperature sensor Type: PTC, KTY sensor, Thermo-Click
15	T2 motor	Negative input for motor temperature sensor
Power supply		
9	+24 V OUT	Power supply output 24 V DC, max. 200 mA
28	GND	Reference potential of the power supply/ internal electronics ground
1	+10 V OUT	Power supply output 10 V DC ±0.5 V, max. 10 mA
2	GND	Reference potential of the power supply/ internal electronics ground
31	+24 V IN	Power supply input 18 ... 30 V DC, max. 1500 mA
32	GND IN	Reference potential of the power supply input
35	+10 V OUT	Power supply output 10 V DC ±0.5 V max. 10 mA
36	GND	Reference potential of the power supply/ internal electronics ground

SINAMICS G120

Standard inverters 0.37 kW to 250 kW (0.5 hp to 400 hp)

CU230 Control Units

Integration

4

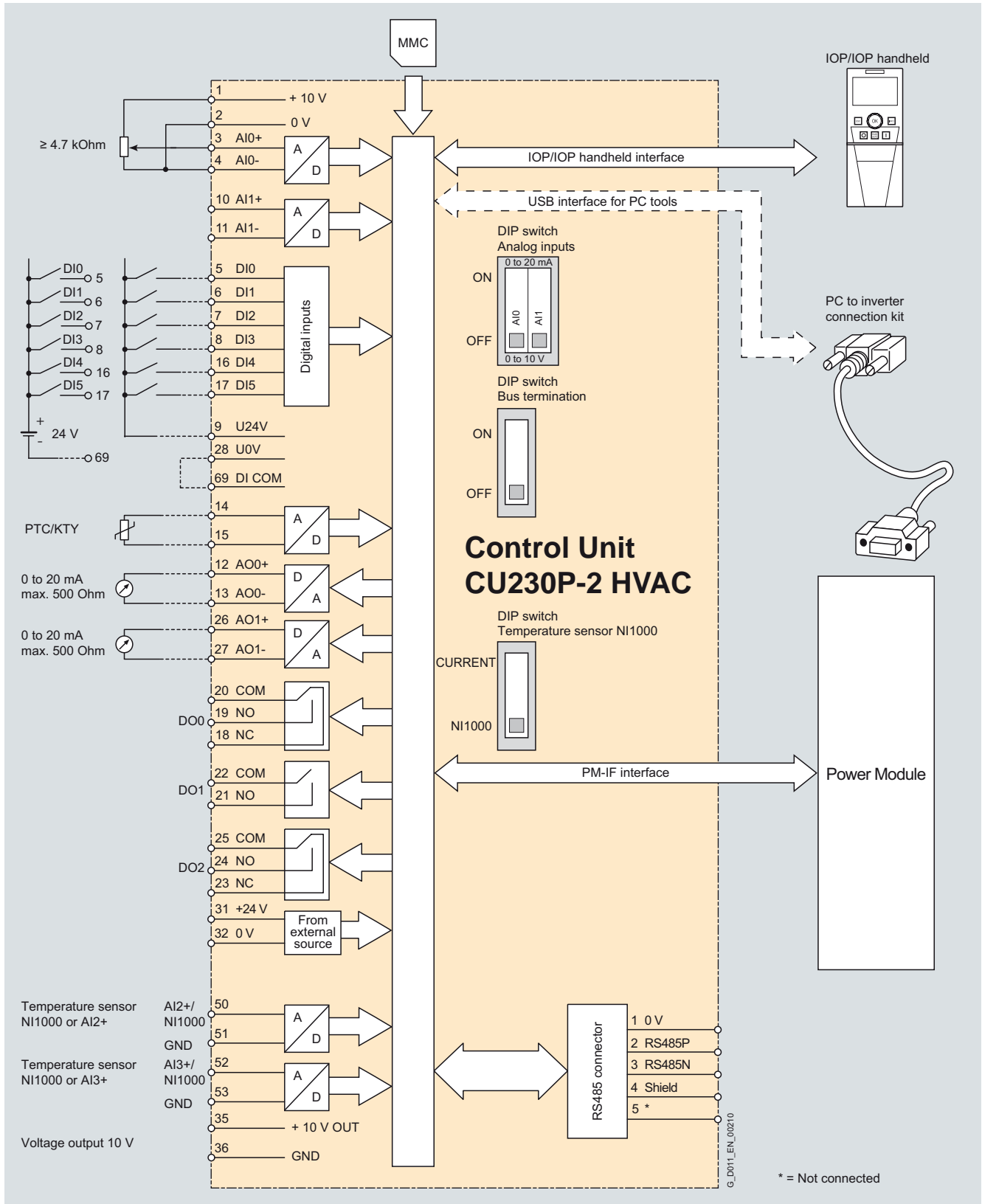

CU230P-2 HVAC Control Unit connection diagram

Integration

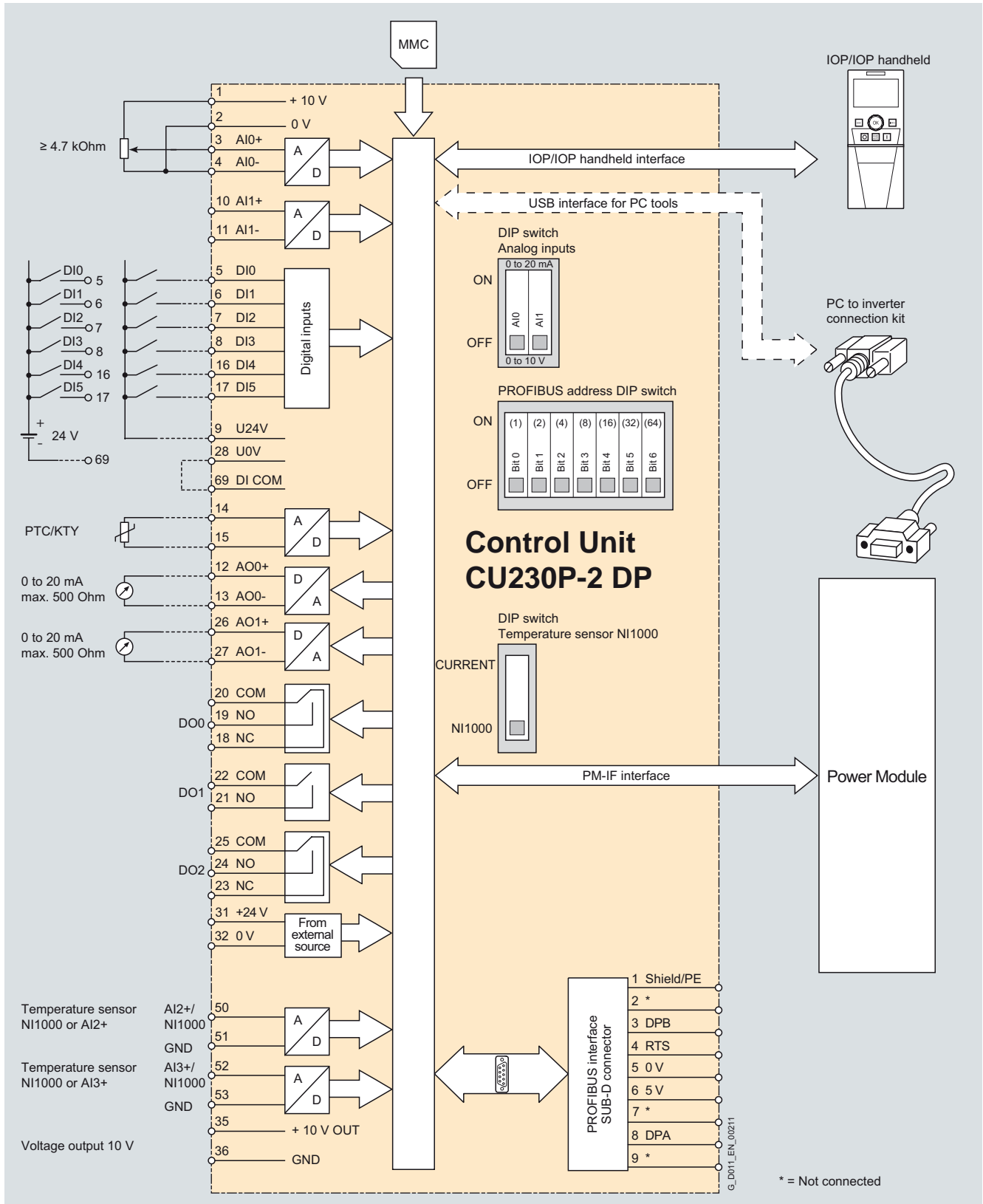

CU230P-2 DP Control Unit connection diagram

SINAMICS G120

Standard inverters 0.37 kW to 250 kW (0.5 hp to 400 hp)

CU230 Control Units

Integration

4

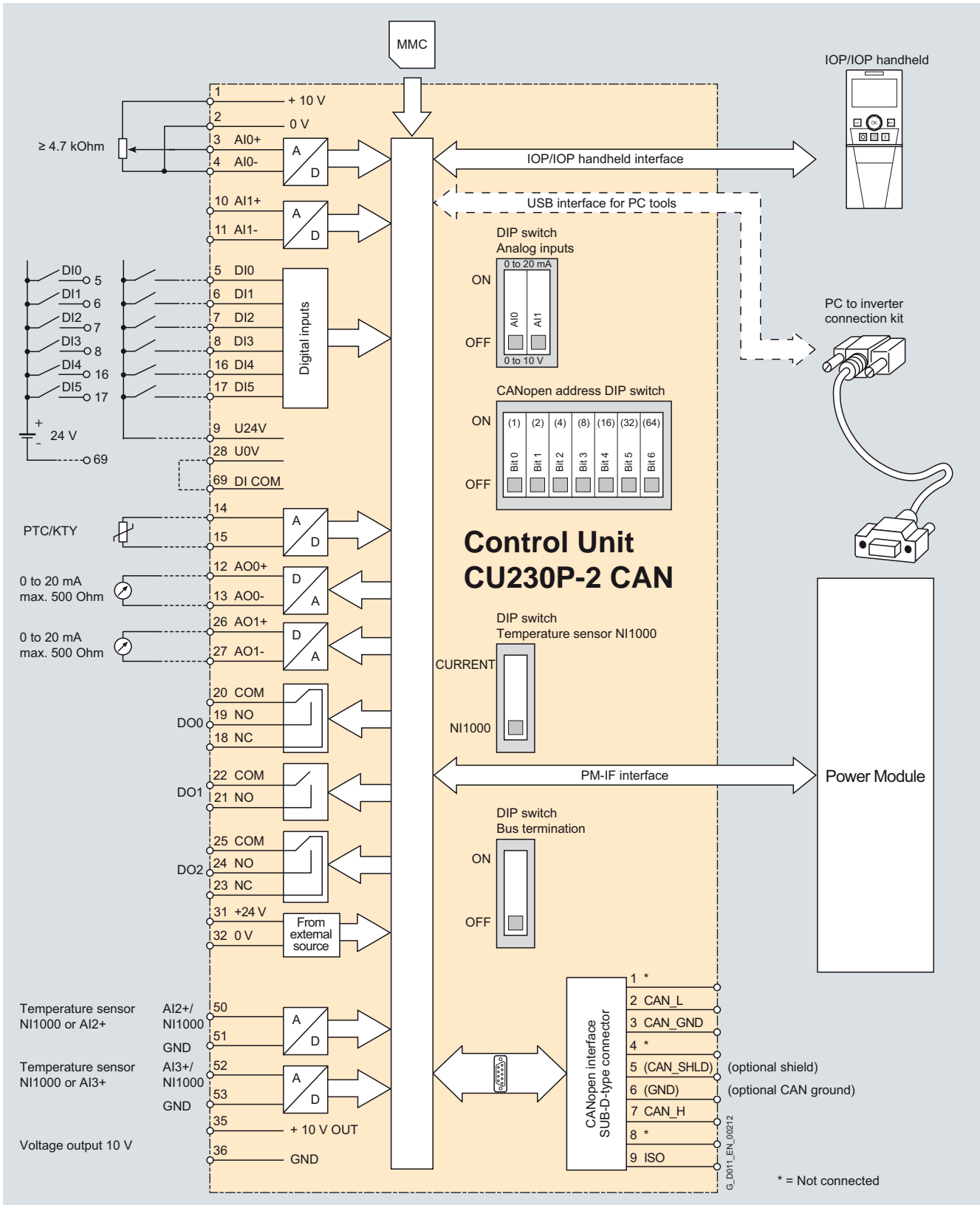

CU230P-2 CAN Control Unit connection diagram

SINAMICS G120

Standard inverters 0.37 kW to 250 kW (0.5 hp to 400 hp)

CU230 Control Units

Technical specifications

Control Unit	CU230P-2 HVAC 6SL3243-0BA30-1HA0	CU230P-2 DP 6SL3243-0BA30-1PA0	CU230P-2 CAN 6SL3243-0BA30-1CA0
Electrical specifications			
Operating voltage	24 V DC from the Power Module or from the connection of an external power supply 18 ... 30 V DC		
Current consumption	Max. 0.5 A		
Protective insulation	PELV according to EN 50178 Protective separation from the line supply using double/reinforced insulation		
Power loss	<5.5 W		
Interfaces			
Digital inputs – Standard	6 isolated inputs, optically isolated; free reference potential (own potential group) NPN/PNP logic can be selected using the wiring Switching level: 0 → 1: 11 V Switching level: 1 → 0: 5 V Max. input current 15 mA		
Digital outputs	2 relay change-over contacts 250 V AC 2 A (inductive load), 30 V DC 5 A (ohmic load) 1 relay NO contact 30 V DC, 0.5 A (ohmic load)		
Analog inputs	2 differential inputs, switchable between voltage and current using DIP switch: –10 ... +10 V, 0/4 ... 20 mA, 10-bit resolution 1 non-isolated input, switchable using DIP switch between current and temperature sensor, type NI1000/PT1000, 0/4 ... 20 mA; 10-bit resolution 1 non-isolated input, temperature sensor, type NI1000/PT1000, 10-bit resolution The two differential analog inputs can be configured as additional digital inputs. Switching thresholds: 0 → 1: Rated voltage 4 V 1 → 0: Rated voltage 1.6 V Analog inputs are protected against inputs in a voltage range of ±30 V and have a common-mode voltage in the ±15 V range.		
Analog outputs	2 non-isolated outputs, switchable between voltage and current using parameter setting: 0 ... 10 V; 0/4 ... 20 mA Voltage mode: 10 V, min. burden 10 kΩ current mode: 20 mA, max. burden 500 Ω The analog outputs have short circuit protection		
PTC/KTY interface	1 motor temperature sensor input, sensors that can be connected PTC, KTY and Thermo-Click, accuracy ±5 °C		
Bus interface			
Type	RS485	PROFIBUS DP	CANopen
Protocols	USS Modbus RTU (switchable per software)	ProfiDrive profile V4.1	CANopen
Hardware	Terminal Insulated USS: max. 187.5 kBaud Modbus RTU: 19.2 kBaud bus terminating resistors can be switched in	9-pin SUB-D connector Insulated Max. 12 Mbit/s Slave address can be set using DIP switches	9-pin SUB-D socket Insulated Max. 1 Mbit/s
Tool interfaces			
Memory card	1 MicroMemoryCard		
Operator panels	IOP supported connection options between CU230P and IOP: can be directly plugged on, door mounting or handheld BOP not possible		
PC interface	USB		
Open-loop/closed-loop control techniques			
V/f linear/square/parameterizable	✓		
V/f with flux current control (FCC)	✓		
V/f ECCO linear/square	✓		
Vector control, without encoder	✓		
Vector control, with encoder	–		
Torque control, without encoder	✓		
Torque control, with encoder	–		

SINAMICS G120

Standard inverters 0.37 kW to 250 kW (0.5 hp to 400 hp)

CU230 Control Units

Technical specifications

Control Unit	CU230P-2 HVAC 6SL3243-0BA30-1HA0	CU230P-2 DP 6SL3243-0BA30-1PA0	CU230P-2 CAN 6SL3243-0BA30-1CA0
Software functions			
Setpoint input	✓		
Fixed frequencies	16, parameterizable		
JOG	✓		
Digital motorized potentiometer (MOP)	✓		
Ramp smoothing	✓		
Extended ramp-function generator (with ramp smoothing Off3)	✓		
Positioning down ramp	–		
Slip compensation	✓		
Signal interconnection with BICO technology	✓		
Free function blocks (FFB) for logic and arithmetic operations	–		
Switchable drive data sets (DDS)	✓ (4)		
Switchable command data sets (CDS)	✓ (4)		
Flying restart	✓		
Automatic restart after line supply failure or operating fault (AR)	✓		
Technology controller (internal PID)	✓		
Energy-saving function (hibernation) with internal PID controller	✓		
Energy-saving function (hibernation) with external PID controller	✓		
Belt monitoring with and without sensor (load torque monitoring)	✓		
Dry pump monitoring (load torque monitoring)	✓		
Thermal motor protection	✓ (I^2t , sensor: PTC/KTY/Thermo-Click)		
Thermal inverter protection	✓		
Motor identification	✓		
Motor holding brake	–		
Auto-ramping (V_{dcmax} controller)	✓ (only with PM240 Power Module)		
Kinetic buffering (V_{dcmax} controller)	✓ (only with PM240 Power Module)		
Braking functions for • DC braking • Compound braking • Dynamic braking with integrated brake chopper	✓ (only with PM240 Power Module)		
Mechanical specifications and ambient conditions			
Degree of protection	IP20		
Signal cable cross-section • min. • max.	0.15 mm ² (AWG28) 1.5 mm ² (AWG16)		
Operating temperature	–10 ... +60 °C (14 ... 140 °F)		
Storage temperature	–40 ... +70 °C (–40 ... +158 °F)		
Relative humidity	<95 % RH, condensation not permissible		
Dimensions • Width • Height • Depth	73 mm 199 mm 65.5 mm		
Weight, approx.	0.61 kg		

SINAMICS G120

Standard inverters 0.37 kW to 250 kW (0.5 hp to 400 hp)

CU240 Control Units

Overview



Example of CU240S DP-F Control Unit

The Control Unit performs closed-loop control functions for the inverter. In addition to the closed-loop control, it has additional functions that can be adapted to the particular application through parameterization. Several Control Units are available in different versions:

- CU240E
- CU240S
- CU240S DP
- CU240S DP-F
- CU240S PN
- CU240S PN-F

Safety Integrated functions

The following Safety Integrated functions are integrated in the CU240S DP-F and CU240S PN-F Control Units and, with the exception of the "Safe Brake Control", can be implemented without external circuit elements:

The SINAMICS G120 fail-safe frequency inverter provides four safety functions, certified in accordance with EN 954-1, Category 3 and IEC 61508 SIL 2:

- Safe Torque Off (STO) to protect against active movement of the drive
- Safe Stop 1 (SS1) for continuous monitoring of a safe braking ramp
- Safely Limited Speed (SLS) for protection against dangerous movements when a speed limit is exceeded
- Safe Brake Control (SBC) for controlling motor brakes that are active in the de-energized state, e.g. motor holding brakes

The functions "Safe Stop 1" and "Safely Limited Speed" can both be implemented without having to use a motor sensor or encoder; the implementation cost is minimal. Existing systems in particular can be simply updated with safety technology without the need to change the motor or mechanical system.

The safety functions "Safely Limited Speed" and "Safe Stop 1" are not certified for pull-through loads as in the case of lifting gear and winders.

Safety functions have been extended with firmware V3.2.

Additional information is provided in the part Highlights, section Safety Integrated.

Selection and ordering data

Communication	Digital inputs Standard	Digital inputs Fail-safe	Digital outputs	Encoder interfaces	Designation	Control Unit Order No.
Standard						
RS485/USS	6	–	3	–	CU240E	6SL3244-0BA10-0BA0
RS485/USS	9	–	3	1	CU240S	6SL3244-0BA20-1BA0
PROFIBUS DP	9	–	3	1	CU240S DP	6SL3244-0BA20-1PA0
PROFINET	9	–	3	1	CU240S PN	6SL3244-0BA20-1FA0
Fail-safe for Safety Integrated						
PROFIBUS DP	6	2	3	1	CU240S DP-F	6SL3244-0BA21-1PA0
PROFINET	6	2	3	1	CU240S PN-F	6SL3244-0BA21-1FA0

SINAMICS G120

Standard inverters 0.37 kW to 250 kW (0.5 hp to 400 hp)

CU240 Control Units

Design

CU240E Control Unit

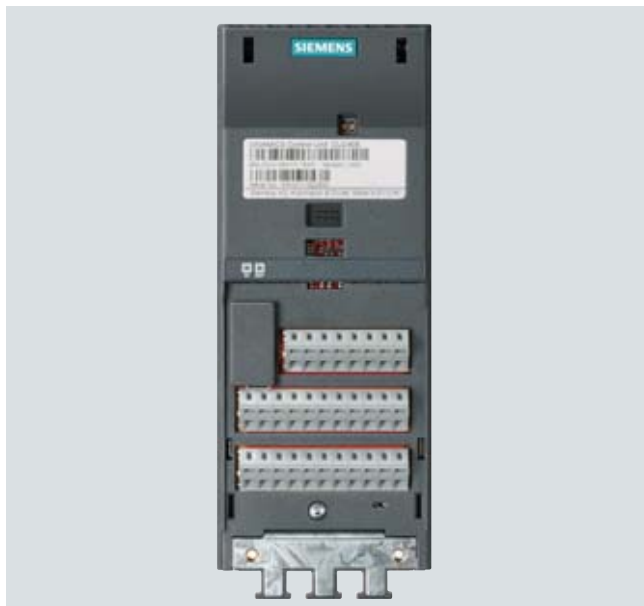

CU240E Control Unit without terminal cover

Terminal No.	Signal	Features
Digital inputs (DI)		
5 ... 8, 16.17	DI0 ... DI5	Freely programmable (isolated) 5.5 mA/24 V
Digital outputs (DO)		
18	DO0, NC	Relay output 1 NC contact (0.5 A, 30 V DC)
19	DO0, NO	Relay output 1 NO contact (0.5 A, 30 V DC)
20	DO0, COM	Relay output 1 Common contact (0.5 A, 30 V DC)
21	DO1, NO	Relay output 2 NO contact (0.5 A, 30 V DC)
22	DO1, COM	Relay output 2 Common contact (0.5 A, 30 V DC)
23	DO2, NC	Relay output 3 NC contact (0.5 A, 30 V DC)
24	DO2, NO	Relay output 3 NO contact (0.5 A, 30 V DC)
25	DO2, COM	Relay output 3 Common contact (0.5 A, 30 V DC)
Analog inputs (AI)		
3	AI0+	0 ... 10 V, -10 ... +10 V, 0/2 ... 10 V or 0/4 ... 20 mA
4	AI0-	
10	AI1+	0 ... 10 V, 0 ... 20 mA
11	AI1-	
Analog outputs (AO)		
12	AO0+	Freely programmable (0/4 ... 20 mA with max. 500 Ω, 0/2 ... 10 V with min. 500 Ω)
13	AO0-	M
26	AO1+	Freely programmable (0/4 ... 20 mA with max. 500 Ω)
27	AO1-	M
PTC/KTY interface		
14	PTC+	Positive PTC/KTY input
15	PTC-	Negative PTC/KTY input
Serial RS485 interface		
29	P+	RS485 A, USS protocol
30	N-	RS485 B, USS protocol
Power supply		
9	U 24 V	Isolated user power supply +24 V at 100 mA
28	U 0 V	Isolated user reference voltage
1	+10 V	Non-isolated, regulated 10 V power supply for I/O – max. 10 mA
2	0 V	Power supply reference

Design

CU240S, CU240S DP, CU240S DP-F, CU240S PN and CU240S PN-F Control Units



Example: CU240S DP-F Control Unit (right without terminal cover, with pluggable terminals)

Terminal No.	Signal	Features
Digital inputs (DI) – Standard		
5 ... 8, 16.17	DI0 ... DI5	Freely programmable (isolated) 5.5 mA/24 V
40 ... 42 (only for CU240S, CU240S DP and CU240S PN)	DI6 ... DI8	Freely programmable (isolated) 5.5 mA/24 V
Digital inputs (DI) – Fail-safe (for CU240S DP-F and CU240S PN-F only)		
60 ... 63 (for CU240S DP-F and CU240S PN-F only)	FDI0A FDI0B FDI1A FDI1B	Fail-safe digital inputs, 2 channels (redundant), freely programmable (isolated) 5.5 mA/24 V
Digital outputs (DO)		
18	DO0, NC	Relay output 1 NC contact (0.5 A, 30 V DC)
19	DO0, NO	Relay output 1 NO contact (0.5 A, 30 V DC)
20	DO0, COM	Relay output 1 Common contact (0.5 A, 30 V DC)
21	DO1, NO	Relay output 2 NO contact (0.5 A, 30 V DC)
22	DO1, COM	Relay output 2 Common contact (0.5 A, 30 V DC)
23	DO2, NC	Relay output 3 NC contact (0.5 A, 30 V DC)
24	DO2, NO	Relay output 3 NO contact (0.5 A, 30 V DC)
25	DO2, COM	Relay output 3 Common contact (0.5 A, 30 V DC)

Terminal No.	Signal	Features
Analog inputs (AI)		
3	AI0+	0 ... 10 V, -10 ... +10 V, 0/2 ... 10 V or 0/4 ... 20 mA
4	AI0-	
10	AI1+	0 ... 10 V, 0 ... 20 mA
11	AI1-	
Analog outputs (AO)		
12	AO0+	Freely programmable (0/4 ... 20 mA with max. 500 Ω, 0/2 ... 10 V with min. 500 Ω)
13	AO0-	M
26	AO1+	Freely programmable (0/4 ... 20 mA with max. 500 Ω)
27	AO1-	M
Encoder interface		
70	ENC AP	Encoder AP Channel A non-inverting input
71	ENC AN	Encoder AN Channel A inverting input
72	ENC BP	Encoder BP Channel B non-inverting input
73	ENC BN	Encoder BN Channel B inverting input
74	ENC ZP	Encoder ZP Zero pulse non-inverting input
75	ENC ZN	Encoder ZN Zero pulse inverting input
PTC/KTY interface		
14	PTC+	Positive PTC/KTY input
15	PTC-	Negative PTC/KTY input
Power supply		
33	ENC+ line supply	Isolated encoder power supply (+24 V at 100 mA, +5 V at 300 mA), configured using DIP switch
9	U 24 V	Isolated user power supply +24 V at 100 mA
28	U 0 V	Isolated encoder power supply and user reference voltage
1	+10 V	Non-isolated, regulated 10 V power supply for I/O – max. 10 mA
2	0 V	Power supply reference
31	+24 V	24 V power supply input
32	0 V	24 V power supply reference

SINAMICS G120

Standard inverters 0.37 kW to 250 kW (0.5 hp to 400 hp)

CU240 Control Units

Integration

4

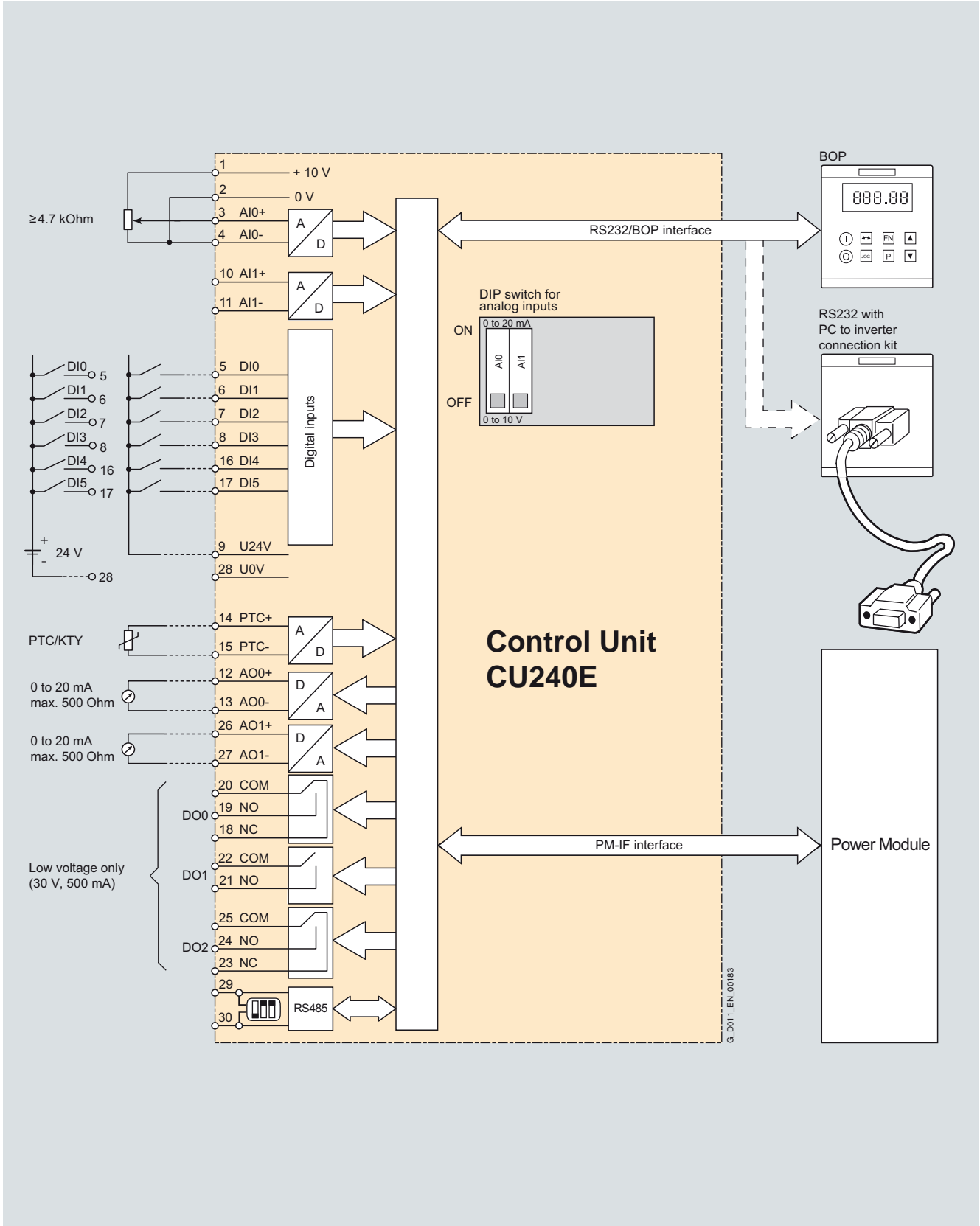

CU240E Control Unit connection diagram

Integration

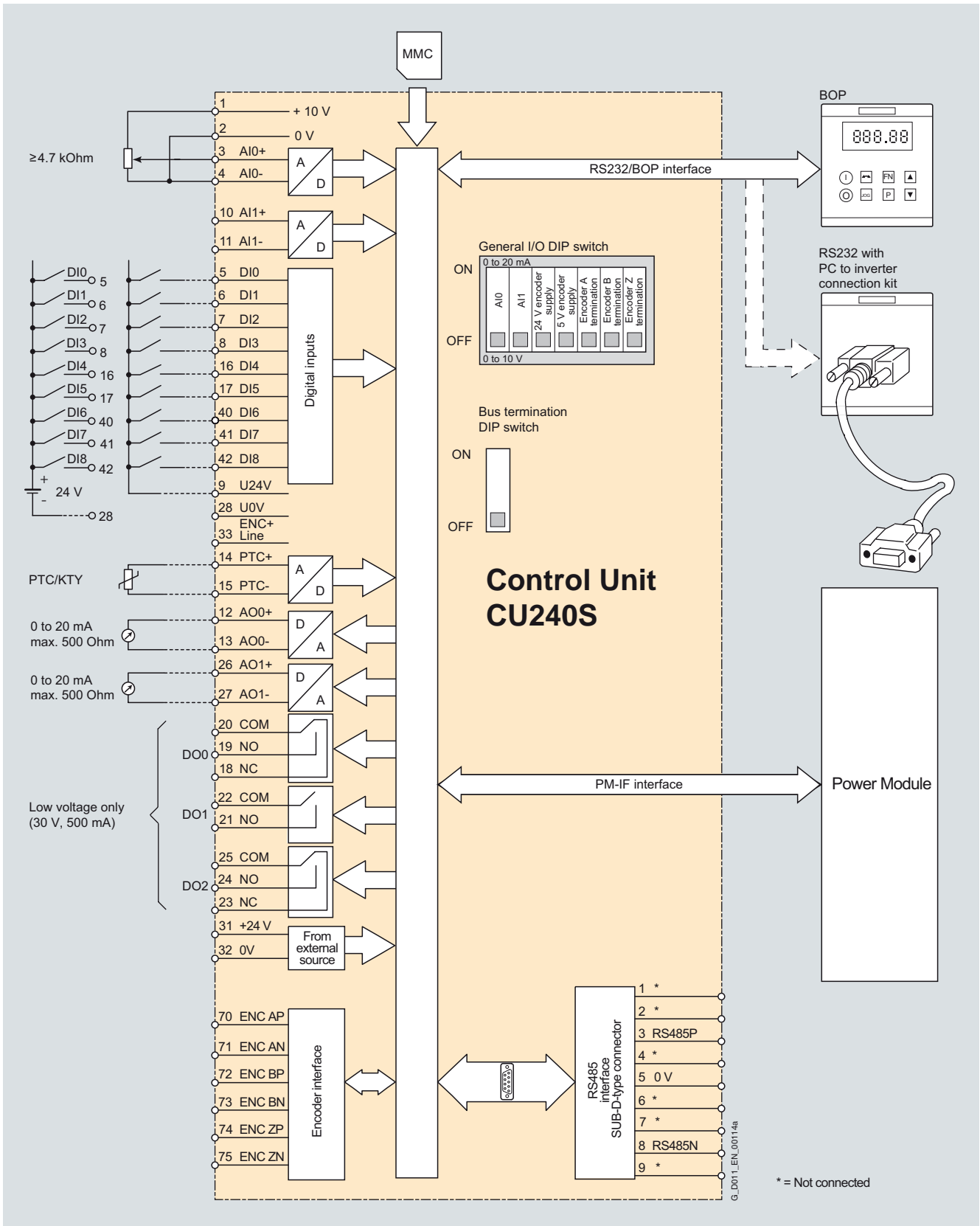

CU240S Control Unit connection diagram

SINAMICS G120

Standard inverters 0.37 kW to 250 kW (0.5 hp to 400 hp)

CU240 Control Units

Integration

4

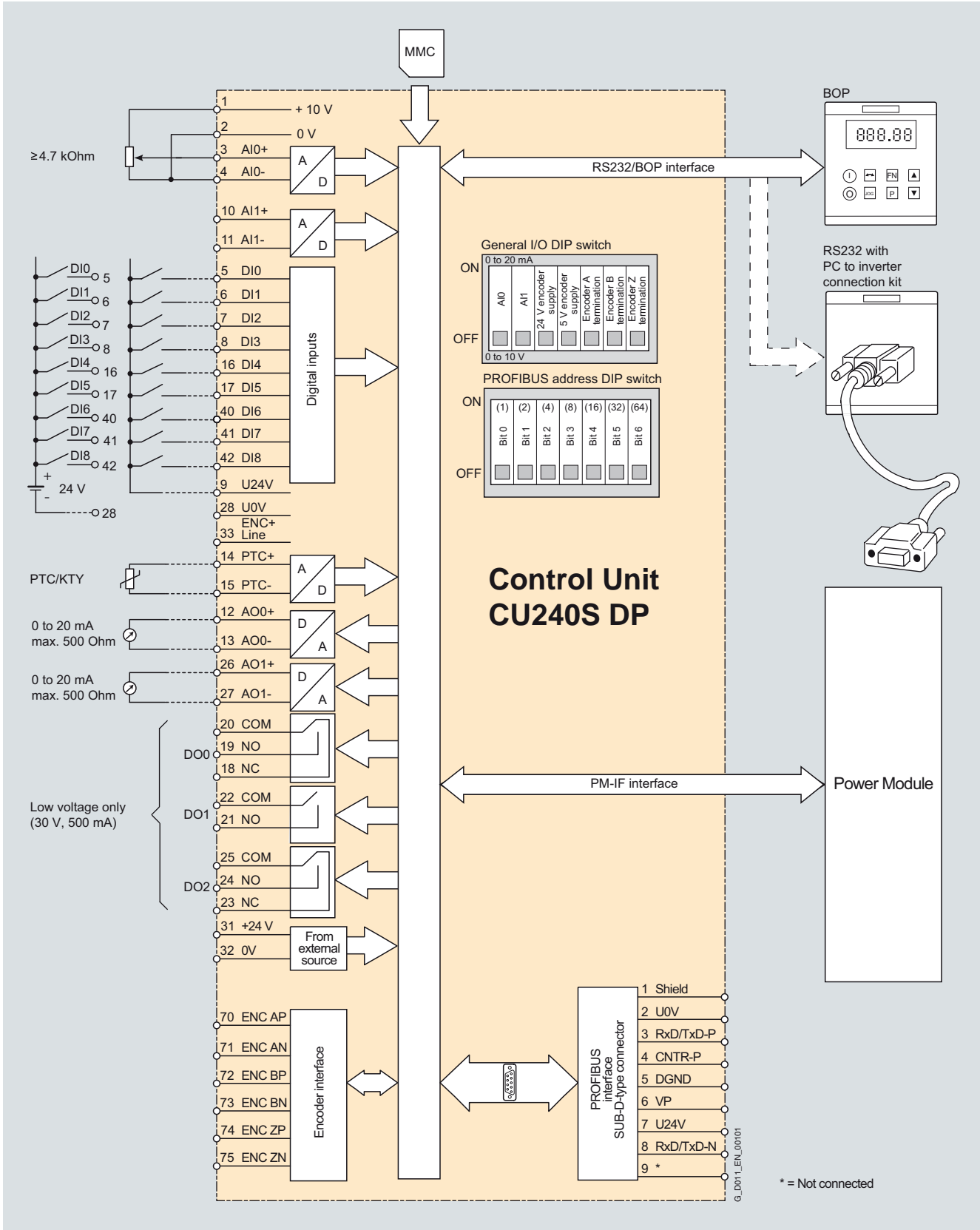

CU240S DP Control Unit connection diagram

Integration

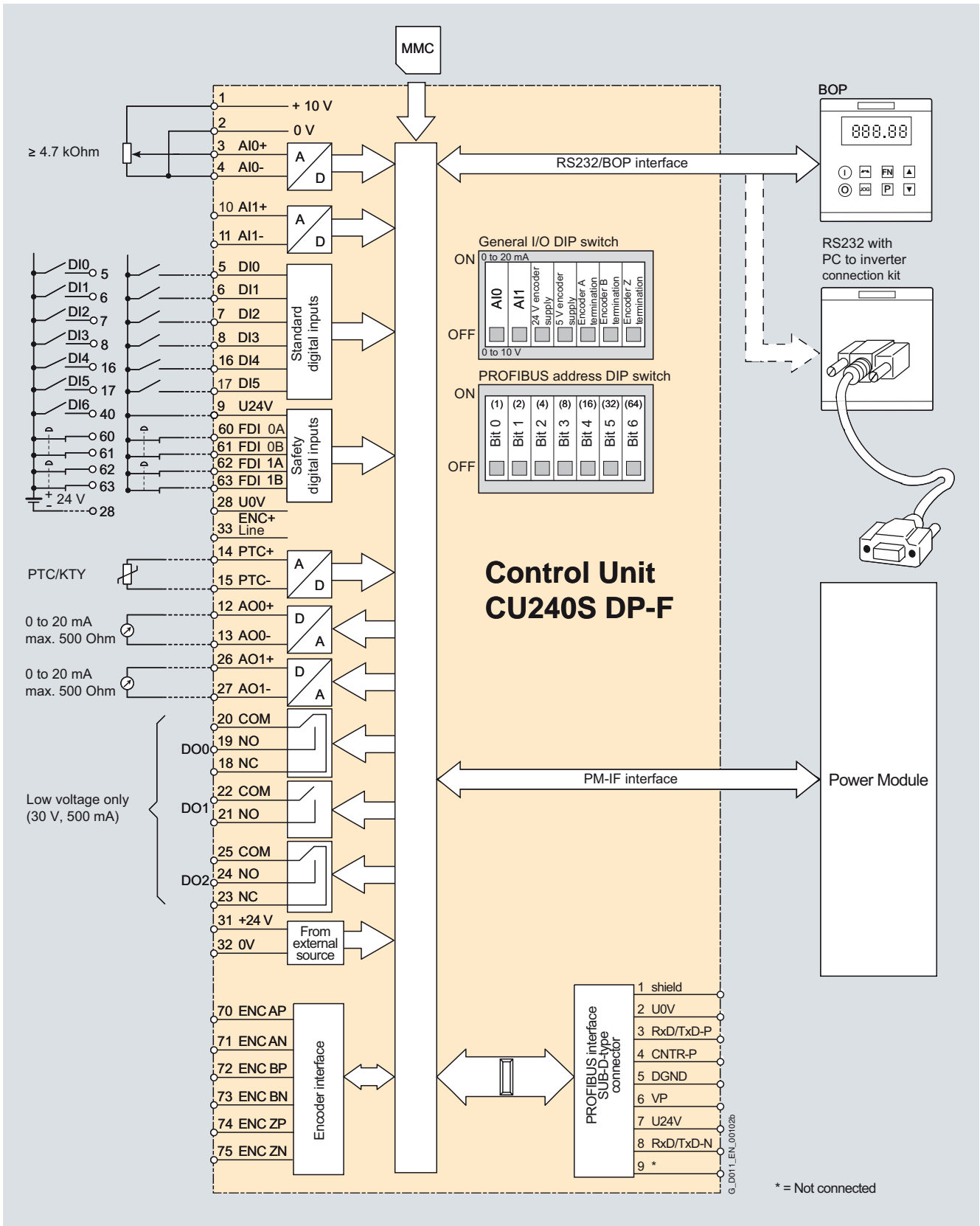

CU240S DP-F Control Unit connection diagram

SINAMICS G120

Standard inverters 0.37 kW to 250 kW (0.5 hp to 400 hp)

CU240 Control Units

Integration

4

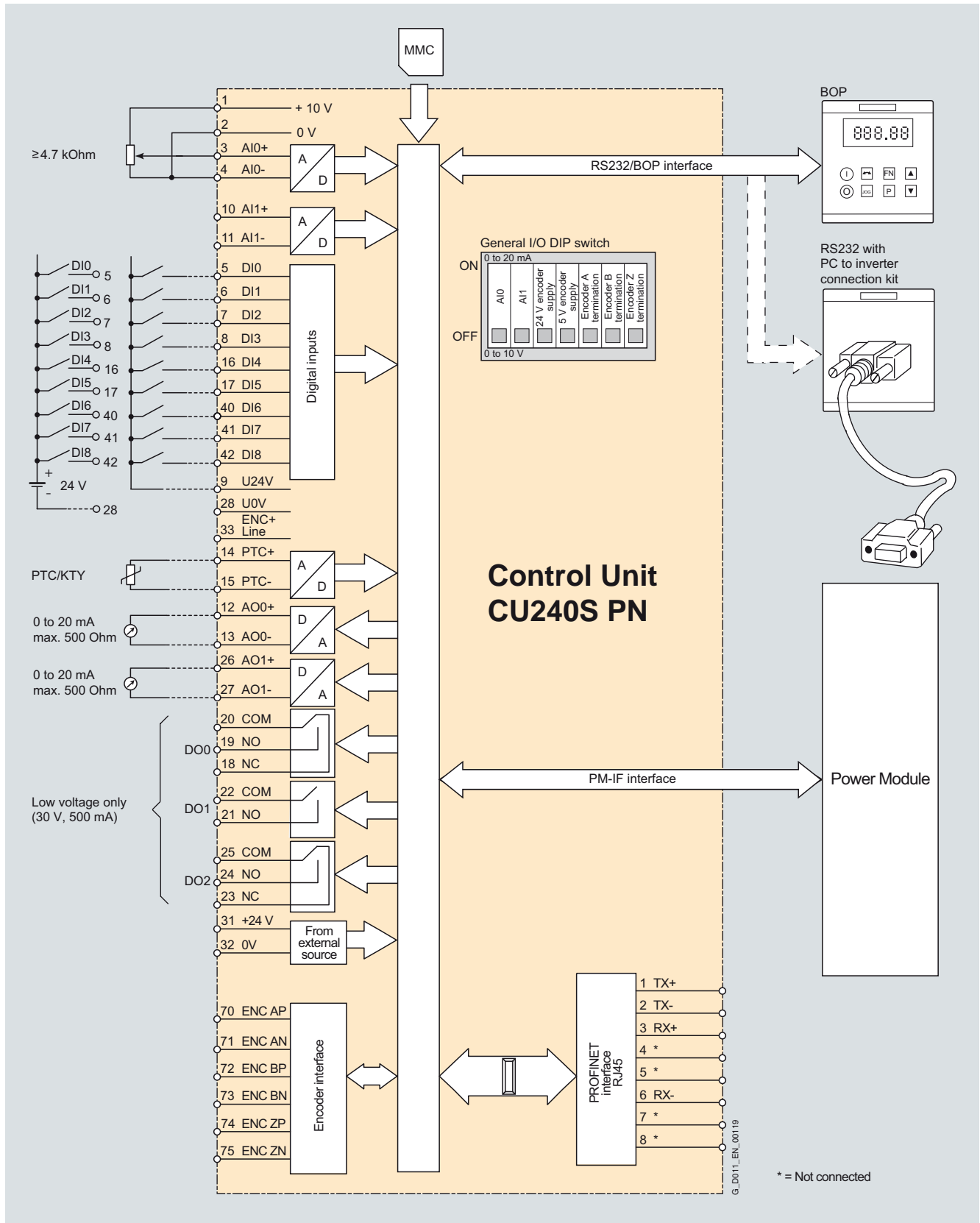

CU240S PN Control Unit connection diagram

Integration

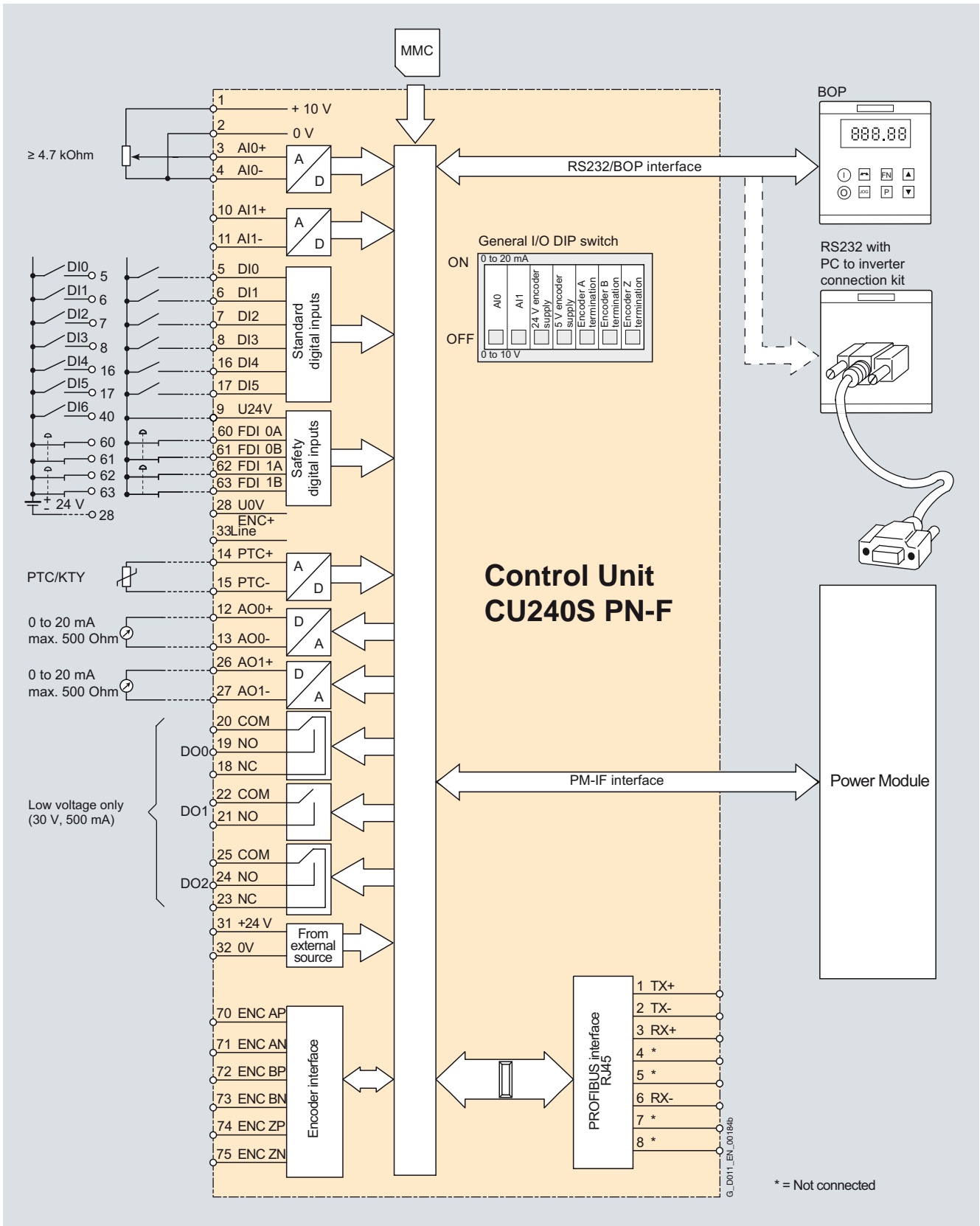

CU240S PN-F Control Unit connection diagram

SINAMICS G120

Standard inverters 0.37 kW to 250 kW (0.5 hp to 400 hp)

CU240 Control Units

Technical specifications

Control Unit	CU240E 6SL3244- 0BA10-0BA0	CU240S 6SL3244- 0BA20-1BA0	CU240S DP 6SL3244- 0BA20-1PA0	CU240S PN 6SL3244- 0BA20-1FA0	CU240S DP-F 6SL3244- 0BA21-1PA0	CU240S PN-F 6SL3244- 0BA21-1FA0
Electrical specifications						
Operating voltage	24 V DC via the Power Module	24 V DC via the Power Module or external 24 V DC	24 V DC via the Power Module or external 24 V DC	24 V DC via the Power Module or external 24 V DC	24 V DC via the Power Module or external 24 V DC	24 V DC via the Power Module or external 24 V DC
Current drain from the 24 V supply	Available soon	Max. 0.5 A	Max. 0.5 A	Max. 0.7 A	Max. 0.7 A	Max. 0.7 A
Power loss (full load)	< 5.5 W	< 5.5 W	< 5.5 W	< 13 W	< 16 W	< 17 W
Interfaces						
Digital inputs – Standard	6	9	9	9	6	6
Digital inputs – Fail-safe	–	–	–	–	2	2
Digital outputs	3	3	3	3	3	3
Analog inputs	2	2	2	2	2	2
	Both analog inputs can be configured as supplementary digital inputs if an additional function is required. Switching thresholds: 0 → 1: Rated voltage 2 V 1 → 0: Rated voltage 0.8 V Analog inputs are protected against inputs in a voltage range of ±30 V and have a common-mode voltage in the ±15 V range.					
Analog outputs	2	2	2	2	2	2
	Analog outputs have short-circuit protection, but are not isolated. Maximum output voltage = 10 V in the current mode, maximum output current = 20 mA in the voltage mode. The response time should be approximately 1 ms at a load of max. 10 kΩ in the voltage mode.					
Bus interface	RS485/USS	RS485/USS	PROFIBUS DP	PROFINET	PROFIBUS DP, PROFIsafe	PROFINET, PROFIsafe
Encoder interfaces	–	1	1	1	1	1
PTC/KTY interface	✓	✓	✓	✓	✓	✓
Brake Relay interface or Safe Brake Relay interface (connected via Power Module)	✓	✓	✓	✓	✓	✓
MMC memory card slot	–	✓	✓	✓	✓	✓
Operator panels that can be used	BOP, IOP Hand-held (via PC Inverter Connection Kit)	BOP, IOP Hand-held (via PC Inverter Connection Kit)	BOP, IOP Hand-held (via PC Inverter Connection Kit)	BOP, IOP Hand-held (via PC Inverter Connection Kit)	BOP, IOP Hand-held (via PC Inverter Connection Kit)	BOP, IOP Hand-held (via PC Inverter Connection Kit)
RS232/USS interface (connection via PC Inverter Connection Kit)	✓	✓	✓	✓	✓	✓
Safety functions						
Integrated safety functions acc. to Category 3 of EN 954-1 and acc. to SIL 2 of IEC 61508	–	–	–	–	<ul style="list-style-type: none"> • Safe Stop 1 (SS1) • Safely Limited Speed (SLS) • Safe Brake Control (SBC) • Safe Torque Off (STO) 	
Open-loop/closed-loop control techniques						
V/f linear/square/parameterizable	✓	✓	✓	✓	✓	✓
V/f with flux current control (FCC)	✓	✓	✓	✓	✓	✓
Vector control, without encoder	✓	✓	✓	✓	✓	✓
Vector control, with encoder	–	✓	✓	✓	✓	✓
Torque control, without encoder	✓	✓	✓	✓	✓	✓
Torque control, with encoder	–	✓	✓	✓	✓	✓

SINAMICS G120

Standard inverters 0.37 kW to 250 kW (0.5 hp to 400 hp)

CU240 Control Units

Technical specifications

Control Unit	CU240E 6SL3244- 0BA10-0BA0	CU240S 6SL3244- 0BA20-1BA0	CU240S DP 6SL3244- 0BA20-1PA0	CU240S PN 6SL3244- 0BA20-1FA0	CU240S DP-F 6SL3244- 0BA21-1PA0	CU240S PN-F 6SL3244- 0BA21-1FA0
Software functions						
Fixed frequencies	16, parameterizable	16, parameterizable	16, parameterizable	16, parameterizable	16, parameterizable	16, parameterizable
Signal interconnection with BICO technology	✓	✓	✓	✓	✓	✓
Automatic restart after line supply failure or operational fault	✓	✓	✓	✓	✓	✓
Positioning down ramp	✓	✓	✓	✓	✓	✓
Slip compensation	✓	✓	✓	✓	✓	✓
Free function blocks (FFB) for logic and arithmetic operations	✓	✓	✓	✓	✓	✓
Ramp smoothing	✓	✓	✓	✓	✓	✓
3 selectable drive data sets	✓	✓	✓	✓	✓	✓
3 selectable command data sets (CDS) (manual/auto)	✓	✓	✓	✓	✓	✓
Flying restart	✓	✓	✓	✓	✓	✓
JOG	✓	✓	✓	✓	✓	✓
Technology controller (PID)	✓	✓	✓	✓	✓	✓
Thermal motor protection	✓	✓	✓	✓	✓	✓
Thermal inverter protection	✓	✓	✓	✓	✓	✓
Setpoint input	✓	✓	✓	✓	✓	✓
Motor identification	✓	✓	✓	✓	✓	✓
Motor holding brake	✓	✓	✓	✓	✓	✓
V_{dcmax} controller	✓ (only with PM240)	✓ (only with PM240)	✓ (only with PM240)	✓ (only with PM240)	✓ (only with PM240)	✓ (only with PM240)
Kinetic buffering	✓ (only with PM240)	✓ (only with PM240)	✓ (only with PM240)	✓ (only with PM240)	✓ (only with PM240)	✓ (only with PM240)
Braking functions for • DC braking • Compound braking • Dynamic braking with integrated brake chopper	✓ (only with PM240)	✓ (only with PM240)	✓ (only with PM240)	✓ (only with PM240)	✓ (only with PM240)	✓ (only with PM240)
Mechanical specifications and ambient conditions						
Degree of protection	IP20	IP20	IP20	IP20	IP20	IP20
Signal cable cross-section						
• min.	0.05 mm ² (AWG30)	0.05 mm ² (AWG30)	0.05 mm ² (AWG30)	0.05 mm ² (AWG30)	0.05 mm ² (AWG30)	0.05 mm ² (AWG30)
• max.	2 mm ² (AWG14)	2 mm ² (AWG14)	2 mm ² (AWG14)	2 mm ² (AWG14)	2 mm ² (AWG14)	2 mm ² (AWG14)
Operating temperature	-10 ... +50 °C (14 ... 122 °F)	-10 ... +50 °C (14 ... 122 °F)	-10 ... +50 °C (14 ... 122 °F)	-10 ... +50 °C (14 ... 122 °F)	0 ... 45 °C (32 ... 113 °F)	0 ... 40 °C (32 ... 104 °F)
Storage temperature	-40 ... +70 °C (-40 ... +158 °F)	-40 ... +70 °C (-40 ... +158 °F)	-40 ... +70 °C (-40 ... +158 °F)	-40 ... +70 °C (-40 ... +158 °F)	-40 ... +70 °C (-40 ... +158 °F)	-40 ... +70 °C (-40 ... +158 °F)
Relative humidity	< 95 % RH, condensation not permissible	< 95 % RH, condensation not permissible	< 95 % RH, condensation not permissible	< 95 % RH, condensation not permissible	< 95 % RH, condensation not permissible	< 95 % RH, condensation not permissible
Dimensions						
• Width	73 mm	73 mm	73 mm	73 mm	73 mm	73 mm
• Height	195 mm	177 mm	177 mm	177 mm	177 mm	177 mm
• Depth	31 mm	63 mm	63 mm	63 mm	63 mm	63 mm
Weight, approx.	0.21 kg	0.52 kg	0.52 kg	0.52 kg	0.52 kg	0.52 kg

SINAMICS G120

Standard inverters 0.37 kW to 250 kW (0.5 hp to 400 hp)

PM240 Power Modules –
0.37 kW to 250 kW (0.5 hp to 400 hp)

Overview



Example: SINAMICS G120, frame sizes FSA to FSF



Example: SINAMICS G120, frame size FSGX

PM240 Power Modules, frame sizes FSA to FSF have an integrated brake chopper to which an external braking resistor can be connected via terminals DCP/R1 and R2 (see DC link components).

PM240 Power Modules, frame size FSGX do not have an integrated brake chopper. For these devices, there is an optional pluggable braking module to connect a braking resistor.

The PM240 Power Module can be used to couple the DC links of up to 10 Power Modules. This functionality is used for applications such as safe power-down after power failure or kinetic buffering (the DC link is supplied in the generator mode with the kinetic energy of the load so that the DC link voltage can be maintained).

The PM240 Power Module is also designed for safety-oriented applications. In conjunction with a Fail-safe Control Unit, the drive can be turned into a Safety Integrated Drive (see Control Units).

The permissible cable lengths between inverter and motor are limited. Longer cables can be used if output reactors are connected (see load-side power components).

Line reactors are available to minimize line harmonics (see line-side components).

Frame size FSA of the PM240 Power Module is available only without integrated line filter to class A. A base filter is therefore available so that class A can be achieved. A class B base filter is also available so that class B can be achieved (see line-side power components).

Frame sizes FSB and FSC of the PM240 Power Module are available both with and without integrated class A line filter. For compliance with class B, PM240 Power Modules with integrated class A line filter must be fitted additionally with a class B base filter (see line-side components).

Power Modules with integrated class A line filter are suitable for connection to TN supply systems. Power Modules without integrated line filter can be connected to grounded (TN, TT) and non-grounded (IT) supply systems.

SINAMICS G120

Standard inverters 0.37 kW to 250 kW (0.5 hp to 400 hp)

PM240 Power Modules –
0.37 kW to 250 kW (0.5 hp to 400 hp)

Selection and ordering data

To ensure that a suitable Power Module is selected, the following currents should be used for applications:

- **rated output current for applications with light overload (LO)**
- **base load current for applications with high overload (HO)**

With reference to the rated output current, the modules support at least 2-pole to 6-pole low-voltage motors, e.g. the new 1LE1 motor series (please refer to the Appendix for further information). The rated power is merely a guide value. For a description of the overload performance, please refer to the general technical specifications of the Power Modules.

Rated power ¹⁾		Rated output current ²⁾ I_{rated}		Power based on the base load current ³⁾		Base load current ³⁾ I_H	Frame size	SINAMICS G120 PM240 Power Module without integrated line filter	SINAMICS G120 PM240 Power Module with integrated class A line filter
kW	hp	A	kW	hp	A				
380 ... 480 V 3 AC									
0.37	0.50	1.3	0.37	0.50	1.3	FSA	6SL3224-0BE13-7UA0	–	
0.55	0.75	1.7	0.55	0.75	1.7	FSA	6SL3224-0BE15-5UA0	–	
0.75	1.0	2.2	0.75	1.0	2.2	FSA	6SL3224-0BE17-5UA0	–	
1.1	1.5	3.1	1.1	1.5	3.1	FSA	6SL3224-0BE21-1UA0	–	
1.5	2.0	4.1	1.5	2.0	4.1	FSA	6SL3224-0BE21-5UA0	–	
2.2	3.0	5.9	2.2	3.0	5.9	FSB	6SL3224-0BE22-2UA0	6SL3224-0BE22-2AA0	
3.0	4.0	7.7	3.0	4.0	7.7	FSB	6SL3224-0BE23-0UA0	6SL3224-0BE23-0AA0	
4.0	5.0	10.2	4.0	5.0	10.2	FSB	6SL3224-0BE24-0UA0	6SL3224-0BE24-0AA0	
7.5	10	18	5.5	7.5	13.2	FSC	6SL3224-0BE25-5UA0	6SL3224-0BE25-5AA0	
11.0	15	25	7.5	10	19	FSC	6SL3224-0BE27-5UA0	6SL3224-0BE27-5AA0	
15.0	20	32	11.0	15	26	FSC	6SL3224-0BE31-1UA0	6SL3224-0BE31-1AA0	
18.5	25	38	15.0	20	32	FSD	6SL3224-0BE31-5UA0	6SL3224-0BE31-5AA0	
22	30	45	18.5	25	38	FSD	6SL3224-0BE31-8UA0	6SL3224-0BE31-8AA0	
30	40	60	22	30	45	FSD	6SL3224-0BE32-2UA0	6SL3224-0BE32-2AA0	
37	50	75	30	40	60	FSE	6SL3224-0BE33-0UA0	6SL3224-0BE33-0AA0	
45	60	90	37	50	75	FSE	6SL3224-0BE33-7UA0	6SL3224-0BE33-7AA0	
55	75	110	45	60	90	FSF	6SL3224-0BE34-5UA0	6SL3224-0BE34-5AA0	
75	100	145	55	75	110	FSF	6SL3224-0BE35-5UA0	6SL3224-0BE35-5AA0	
90	125	178	75	100	145	FSF	6SL3224-0BE37-5UA0	6SL3224-0BE37-5AA0	
110	150	205	90	125	178	FSF	6SL3224-0BE38-8UA0	–	
132	200	250	110	150	205	FSF	6SL3224-0BE41-1UA0	–	
160	250	302	132	200	250	FSGX	new 6SL3224-0XE41-3UA0	–	
200	300	370	160	250	302	FSGX	new 6SL3224-0XE41-6UA0	–	
250	400	477	200	300	370	FSGX	new 6SL3224-0XE42-0UA0	–	

¹⁾ Rated power based on the rated output current I_{rated} . The rated output current I_{rated} is based on the duty cycle for light overload (LO).

²⁾ The rated output current I_{rated} is based on the duty cycle for light overload (LO). These current values are valid for 400 V and are stamped on the rating plate of the Power Module.

³⁾ The base load current I_H is based on the duty cycle for high overload (HO).

SINAMICS G120

Standard inverters 0.37 kW to 250 kW (0.5 hp to 400 hp)

PM240 Power Modules – 0.37 kW to 250 kW (0.5 hp to 400 hp)

Integration

PM240 Power Modules communicate with the Control Unit via the PM-IF interface.

PM240 Power Modules have the following interfaces as standard:

- PM-IF interface to connect the PM240 Power Module to the Control Unit. The PM240 Power Module also supplies power to the Control Unit using an integrated power supply
- Terminals DCP/R1 and R2 for connection of an external braking resistor, valid up to frame size FSF. For frame size FSGX, an external plug-in braking unit (Braking Module) is required to connect a braking resistor
- Motor connection using screw terminals or screw studs
- Control for the Brake Relay or the Safe Brake Relay for controlling a motor brake
- 2 PE/protective conductor connections

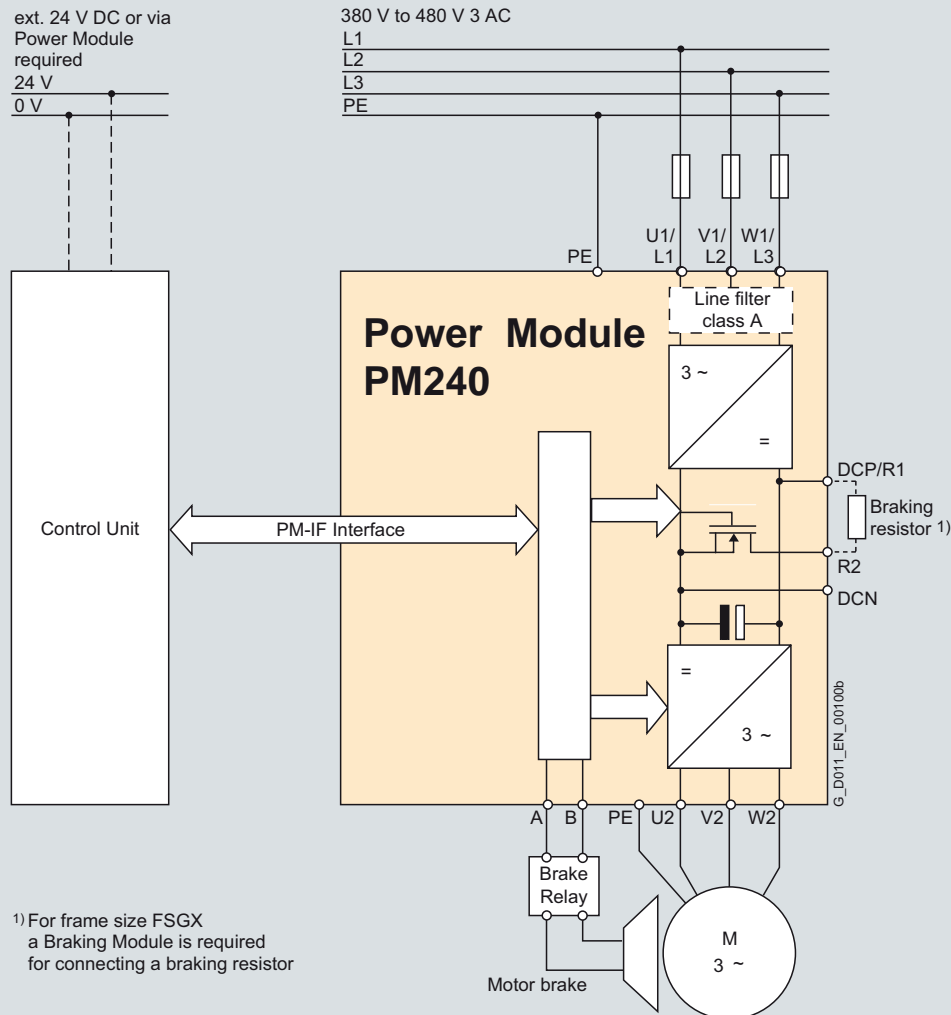

PM240 Power Module connection diagram with or without integrated class A line filter

SINAMICS G120

Standard inverters 0.37 kW to 250 kW (0.5 hp to 400 hp)

PM240 Power Modules –
0.37 kW to 250 kW (0.5 hp to 400 hp)

Integration

Power and DC link components which are optionally available depending on the Power Module used

The following line-side power components, DC link components and load-side power components are optionally available in the appropriate frame sizes for the Power Modules:

	Frame size						
	FSA	FSB	FSC	FSD	FSE	FSF	FSGX
PM240 Power Module with integrated brake chopper	without integrated brake chopper						
Available frame sizes	✓	✓	✓	✓	✓	✓	✓
Line-side power components							
Line filter, class A	U	F	F	F	F	F/S ¹⁾	S ¹⁾
Line filter, class B	U	U	U	–	–	–	–
Line reactor	U	U	U	U	U	S	S
DC link components							
Braking resistor	U	U	S	S	S	S	S
Braking Module	–	–	–	–	–	–	I (Option)
Load-side power components							
Output reactor	U	U	U	S	S	S	S
Sine-wave filter	U	U	U	S	S	S	S

U = Base component

S = Lateral mounting

I = Integrated

– = Not possible

F = Power Modules available with and without integrated class A filter

¹⁾ PM240 FSF Power Modules from 110 kW (150 hp) and higher and FSGX are only available without an integrated class A filter. An optional class A line filter for side mounting is available instead.

SINAMICS G120

Standard inverters 0.37 kW to 250 kW (0.5 hp to 400 hp)

PM240 Power Modules – 0.37 kW to 250 kW (0.5 hp to 400 hp)

Integration

Many system components for PM240 Power Modules are designed as base components, that is, the component is mounted on the baseplate and the PM240 Power Module above it in a space-saving design. Up to two base components can be mounted above one another.

The following diagram shows the basic layout of a PM240 Power Module with line reactor as base component. On the line side, the line-side reactors have terminals and on the Power Module side, they have a pre-fabricated cable. For frame sizes FSA to FSC, when installed, the line terminals are at the top, for frame sizes FSD to FSE they are at the bottom.

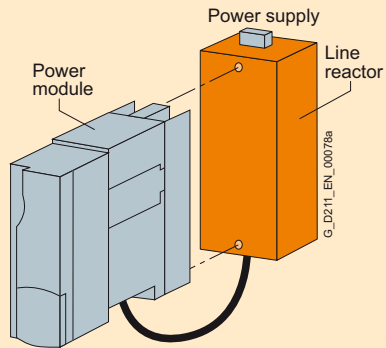

Basic layout of a PM240 Power Module with line reactor as base component

If a class A line filter is installed in addition to the line reactor on frame size FSA, the components must be arranged as shown in the diagram below. In this case, the line connection is from below.

Power Modules, from frame size FSB and higher are available with integrated class A line filters (an external class A line filter is not required in this case).

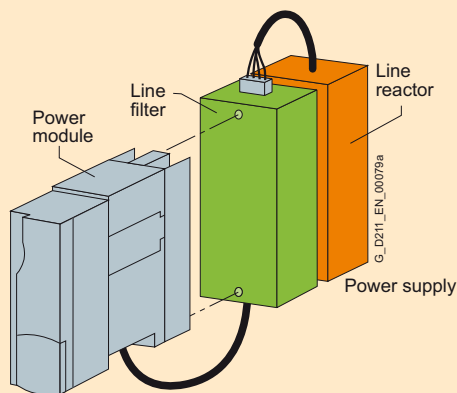

PM240 Power Module frame size FSA with line reactor and class A line filter

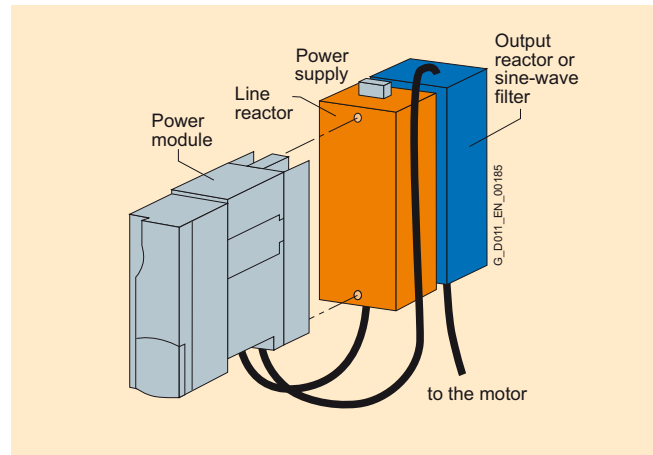

PM240 Power Module frame size FSA with line reactor and output reactor or sine-wave filter

For configurations involving more than two base-type system components, e.g. line filter + line reactor + output reactor, individual components must be mounted to the side of the Power Modules. In this case, the line reactor and line filter must be installed under the Power Module and the output reactor to the righthand side.

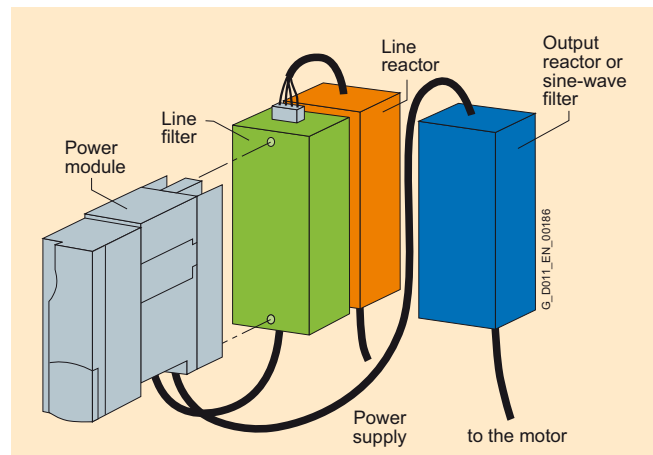

PM240 Power Module frame size FSA with line reactor, line filter and output reactor or sine-wave filter

Standard inverters 0.37 kW to 250 kW (0.5 hp to 400 hp)

PM240 Power Modules –
0.37 kW to 250 kW (0.5 hp to 400 hp)**Integration**

Maximum permissible cable lengths from the motor to the inverter when using output reactors or sine-wave filters depending on the voltage range

The following load-side power components are optionally available in the appropriate frame sizes and result in the following maximum cable lengths:

	Maximum permissible motor cable lengths (shielded/unshielded) in m						
	Frame sizes						
	FSA	FSB	FSC	FSD	FSE	FSF	FSGX
PM240 Power Module with integrated brake chopper							without integrated brake chopper
Available frame sizes	✓	✓	✓	✓	✓	✓	✓
Without output reactor/sine-wave filter	50/100	50/100	50/100	50/100	100/100	150/150	300/450
With optional output reactor							
• at 380 V (–10 %) to 400 V 3 AC	150/225	150/225	150/225	200/300	200/300	200/300	300/450
• at 401 V to 480 V (+10 %) 3 AC	100/150	100/150	100/150	200/300	200/300	200/300	300/450
With optional sine-wave filter							
• at 380 V (–10 %) to 400 V 3 AC	150/225	150/225	150/225	200/300	200/300	200/300	300/450
• at 401 V to 480 V (+10 %) 3 AC	100/150	100/150	100/150	200/300	200/300	200/300	300/450

Derating data

The following inverter output currents can still be implemented for long motor cables without output reactor and sine-wave filter.

Derating for PM240 Power Modules, frame sizes FSA to FSF for shielded motor cables. From frame size FSD and higher, only the particular main Power Module types were tested. The values also apply to the other Power Modules of the particular frame size.

Rated power (at I_H)		Frame size	Base load current I_H	Rated current I_{rated}	Motor connection cross-section	Current derating of the output current as a % of the base load current for the cable lengths (MOTION-CONNECT)			
kW	hp					50 m	100 m	150 m	200 m
0.37	0.50	FSA	1.3	1.3	2.5	100 %	–	–	–
0.55	0.75	FSA	1.7	1.7	2.5	100 %	–	–	–
0.75	1.0	FSA	2.2	2.2	2.5	100 %	–	–	–
1.1	1.5	FSA	3.1	3.1	2.5	100 %	–	–	–
1.5	2.0	FSA	4.1	4.1	2.5	100 %	–	–	–
2.2	3.0	FSB	5.9	5.9	6	100 %	60 %	–	–
3.0	4.0	FSB	7.7	7.7	6	100 %	60 %	–	–
4.0	5.0	FSB	10.2	10.2	6	100 %	70 %	–	–
5.5	7.5	FSC	13.2	18	10	100 %	70 %	45 %	–
7.5	10	FSC	19	25	10	100 %	90 %	80 %	–
11.0	15	FSC	26	32	10	100 %	90 %	80 %	–
22.0	30	FSD	45	60	35	100 %	95 %	90 %	85 %
37.0	50	FSE	75	90	35	100 %	100 %	95 %	90 %
75.0	100	FSF	145	178	95	100 %	100 %	100 %	95 %

– Not possible

SINAMICS G120

Standard inverters 0.37 kW to 250 kW (0.5 hp to 400 hp)

PM240 Power Modules – 0.37 kW to 250 kW (0.5 hp to 400 hp)

Technical specifications

General technical specifications

PM240 Power Modules	
System operating voltage	380 ... 480 V 3 AC ±10 %
Line supply requirements Line short circuit voltage u_K	at $u_K > 1$ %, a line reactor is recommended
Input frequency	47 ... 63 Hz
Output frequency • Control type V/f • Control type Vector	0 ... 650 Hz 0 ... 200 Hz
Pulse frequency	to 75 kW HO: 4 kHz from 90 kW HO: 2 kHz for higher pulse frequencies up to 16 kHz see the derating data
Power factor	0.7 ... 0.85
Inverter efficiency	95 ... 97 %
Modulation depth	93 %
Overload capability • High overload (HO) - 0.37 ... 75 kW - 90 ... 200 kW • Light overload (LO) - 0.37 ... 250 kW	1.5 × rated output current (i.e. 150 % overload) for 57 s with a cycle time of 300 s 2 × rated output current (i.e. 200 % overload) for 3 s with a cycle time of 300 s 1.36 × rated output current (i.e. 136 % overload) for 57 s with a cycle time of 300 s 1.6 × rated output current (i.e. 160 % overload) for 3 s with a cycle time of 300 s 1.1 × rated output current (i.e. 110 % overload) for 57 s with a cycle time of 300 s 1.5 × rated output current (i.e. 150 % overload) for 3 s with a cycle time of 300 s
Electromagnetic compatibility	Optional class A or B line filter acc. to EN 55011 is available
Possible braking methods	• DC braking • Compound braking • Dynamic braking with integrated brake chopper (optional for frame size FSGX)
Degree of protection	IP20
Operating temperature • High overload (HO) - Frame sizes FSD to FSF - Frame size FSGX • Light overload (LO)	0 ... 50 °C (32 ... 122 °F) without derating, > 50 ... 60 °C see derating characteristics 0 ... 40 °C (32 ... 104 °F) without derating, > 40 ... 55 °C see derating characteristics 0 ... 40 °C (32 ... 104 °F) without derating, > 40 ... 60 °C (> 40 ... 55 °C for frame size FSGX) see derating characteristics
Storage temperature	-40 ... +70 °C (-40 ... +158 °F)
Relative humidity	< 95 % RH, condensation not permissible
Cooling	Internal air cooling, power units with increased air cooling using integrated fans
Installation altitude	up to 1000 m above sea level without power reduction, > 1000 m see derating characteristics
Standard SCCR (Short Circuit Current Rating)¹⁾	FSA, FSB, FSC: 10 kA FSD, FSE, FSF, FSGX: 42 kA
Protection functions	• Undervoltage • Overvoltage • Overcontrol/overload • Ground fault • Short circuit • Stall protection • Motor blocking protection • Motor overtemperature • Inverter overtemperature • Parameter locking
Standards conformance	UL, cUL, CE, c-tick, SEMI F47
CE mark	According to Low-Voltage Directive 73/23/EEC and Machinery Directive 98/37/EC

¹⁾ Applies to industrial control cabinet installations to NEC Article 409/UL 508A. For further information, visit us on the Internet at: <http://support.automation.siemens.com/WW/view/en/23995621>

Technical specifications

Line supply voltage 380 ... 480 V 3 AC		PM240 Power Modules				
		6SL3224- 0BE13-7UA0	6SL3224- 0BE15-5UA0	6SL3224- 0BE17-5UA0	6SL3224- 0BE21-1UA0	6SL3224- 0BE21-5UA0
Without integrated line filter						
Output current at 50 Hz 400 V 3 AC						
• Rated current $I_{rated}^{1)}$	A	1.3	1.7	2.2	3.1	4.1
• Base load current $I_L^{1)}$	A	1.3	1.7	2.2	3.1	4.1
• Base load current $I_H^{2)}$	A	1.3	1.7	2.2	3.1	4.1
• I_{max}	A	2.6	3.4	4.4	6.2	8.2
Rated power						
• based on I_L	kW (hp)	0.37 (0.5)	0.55 (0.75)	0.75 (1.0)	1.1 (1.5)	1.5 (2.0)
• based on I_H	kW (hp)	0.37 (0.5)	0.55 (0.75)	0.75 (1.0)	1.1 (1.5)	1.5 (2.0)
Rated pulse frequency	kHz	4	4	4	4	4
Efficiency η		0.97	0.97	0.97	0.97	0.97
Power loss (at rated current)	kW	0.09	0.1	0.1	0.1	0.11
Cooling air requirement	m ³ /s	0.005	0.005	0.005	0.005	0.005
Sound pressure level L_{pA} (1 m)	dB	< 45	< 45	< 45	< 45	< 45
24 V DC power supply for Control Unit	A	1	1	1	1	1
Rated input current ³⁾						
• with line reactor	A	1.4	1.8	2.3	3.2	4.3
• without line reactor	A	1.7	2.1	2.6	3.9	4.9
Max. length of cable to brake resistor	m	15	15	15	15	15
Line supply connection U1/L1, V1/L2, W1/L3		Screw terminals	Screw terminals	Screw terminals	Screw terminals	Screw terminals
• Conductor cross-section	mm ²	1 ... 2.5	1 ... 2.5	1 ... 2.5	1 ... 2.5	1 ... 2.5
Motor connection U2, V2, W2		Screw terminals	Screw terminals	Screw terminals	Screw terminals	Screw terminals
• Conductor cross-section	mm ²	1 ... 2.5	1 ... 2.5	1 ... 2.5	1 ... 2.5	1 ... 2.5
DC link connection, connection for the braking resistor		Screw terminals	Screw terminals	Screw terminals	Screw terminals	Screw terminals
DCP/R1, DCN, R2						
• Conductor cross-section	mm ²	1 ... 2.5	1 ... 2.5	1 ... 2.5	1 ... 2.5	1 ... 2.5
PE connection		On housing with M4 screw	On housing with M4 screw	On housing with M4 screw	On housing with M4 screw	On housing with M4 screw
Motor cable length ⁴⁾, max.						
• Shielded	m	50	50	50	50	50
• Unshielded	m	100	100	100	100	100
Degree of protection		IP20	IP20	IP20	IP20	IP20
Dimensions						
• Width	mm	73	73	73	73	73
• Height	mm	173	173	173	173	173
• Depth						
- without Control Unit	mm	145	145	145	145	145
- with Control Unit	mm	210	210	210	210	210
Frame size		FSA	FSA	FSA	FSA	FSA
Weight, approx.	kg	1.1	1.1	1.1	1.1	1.1

¹⁾ The rated output current I_{rated} and the base load current I_L are based on the duty cycle for light overload (LO).

²⁾ The base load current I_H is based on the duty cycle for high overload (HO).

³⁾ The input current depends on the motor load and line impedance. The input currents apply for a load at rated power (based on I_{rated}) for a line impedance corresponding to $u_K = 1\%$. These current values without line reactor are stamped on the rating plate of the Power Module.

⁴⁾ Max. motor cable length 25 m (shielded) for PM240 Power Modules with integrated line filter to maintain the limit values of EN 61800-3 Category C2.

SINAMICS G120

Standard inverters 0.37 kW to 250 kW (0.5 hp to 400 hp)

PM240 Power Modules – 0.37 kW to 250 kW (0.5 hp to 400 hp)

Technical specifications

Line supply voltage 380 ... 480 V 3 AC		PM240 Power Modules				
Without integrated line filter		6SL3224-0BE22-2UA0	6SL3224-0BE23-0UA0	6SL3224-0BE24-0UA0	6SL3224-0BE25-5UA0	6SL3224-0BE27-5UA0
With integrated line filter		6SL3224-0BE22-2AA0	6SL3224-0BE23-0AA0	6SL3224-0BE24-0AA0	6SL3224-0BE25-5AA0	6SL3224-0BE27-5AA0
Output current at 50 Hz 400 V 3 AC						
• Rated current $I_{rated}^{1)}$	A	5.9	7.7	10.2	18	25
• Base load current $I_L^{1)}$	A	5.9	7.7	10.2	18	25
• Base load current $I_H^{2)}$	A	5.9	7.7	10.2	13.2	19
• I_{max}	A	11.8	15.4	20.4	26.4	38
Rated power						
• based on I_L	kW (hp)	2.2 (3.0)	3 (4)	4 (5)	7.5 (10)	11 (15)
• based on I_H	kW (hp)	2.2 (3.0)	3 (4)	4 (5)	5.5 (7.5)	7.5 (10)
Rated pulse frequency	kHz	4	4	4	4	4
Efficiency η		0.95	0.95	0.95	0.95	0.95
Power loss (at rated current)	kW	0.14	0.16	0.18	0.24	0.30
Cooling air requirement	m ³ /s	0.024	0.024	0.024	0.055	0.055
Sound pressure level L_{pA} (1 m)	dB	< 50	< 50	< 50	< 60	< 60
24 V DC power supply for Control Unit	A	1	1	1	1	1
Rated input current ³⁾						
• with line reactor	A	6.1	8	10.4	18.7	26
• without line reactor	A	7.6	10.2	13.4	21.9	31.5
Max. length of cable to braking resistor	m	15	15	15	15	15
Line supply connection U1/L1, V1/L2, W1/L3						
• Conductor cross-section	mm ²	1 ... 6	1 ... 6	1 ... 6	2.5 ... 10	2.5 ... 10
Motor connection U2, V2, W2						
• Conductor cross-section	mm ²	1 ... 6	1 ... 6	1 ... 6	2.5 ... 10	2.5 ... 10
DC link connection, connection for the braking resistor						
DCP/R1, DCN, R2						
• Conductor cross-section	mm ²	1 ... 6	1 ... 6	1 ... 6	2.5 ... 10	2.5 ... 10
PE connection						
		On housing with M5 screw	On housing with M5 screw	On housing with M5 screw	On housing with M5 screw	On housing with M5 screw
Motor cable length ⁴⁾, max.						
• Shielded	m	50	50	50	50	50
• Unshielded	m	100	100	100	100	100
Degree of protection						
		IP20	IP20	IP20	IP20	IP20
Dimensions						
• Width	mm	153	153	153	189	189
• Height	mm	270	270	270	334	334
• Depth						
- without Control Unit	mm	165	165	165	185	185
- with Control Unit	mm	230	230	230	250	250
Frame size						
		FSB	FSB	FSB	FSC	FSC
Weight, approx.	kg	4	4	4	7	7

¹⁾ The rated output current I_{rated} and the base load current I_L are based on the duty cycle for light overload (LO).

²⁾ The base load current I_H is based on the duty cycle for high overload (HO).

³⁾ The input current depends on the motor load and line impedance. The input currents apply for a load at rated power (based on I_{rated}) for a line impedance corresponding to $u_K = 1\%$. These current values without line reactor are stamped on the rating plate of the Power Module.

⁴⁾ Max. motor cable length 25 m (shielded) for PM240 Power Modules with integrated line filter to maintain the limit values of EN 61800-3 Category C2.

SINAMICS G120

Standard inverters 0.37 kW to 250 kW (0.5 hp to 400 hp)

PM240 Power Modules –
0.37 kW to 250 kW (0.5 hp to 400 hp)

Technical specifications

Line supply voltage 380 ... 480 V 3 AC		PM240 Power Modules				
Without integrated line filter		6SL3224-0BE31-1UA0	6SL3224-0BE31-5UA0	6SL3224-0BE31-8UA0	6SL3224-0BE32-2UA0	6SL3224-0BE33-0UA0
With integrated line filter		6SL3224-0BE31-1AA0	6SL3224-0BE31-5AA0	6SL3224-0BE31-8AA0	6SL3224-0BE32-2AA0	6SL3224-0BE33-0AA0
Output current at 50 Hz 400 V 3 AC						
• Rated current $I_{rated}^{1)}$	A	32	38	45	60	75
• Base load current $I_L^{1)}$	A	32	38	45	60	75
• Base load current $I_H^{2)}$	A	26	32	38	45	60
• I_{max}	A	52	64	76	90	124
Rated power						
• based on I_L	kW (hp)	15 (20)	18.5 (25)	22 (30)	30 (40)	37 (50)
• based on I_H	kW (hp)	11 (15)	15 (20)	18.5 (25)	22 (30)	30 (40)
Rated pulse frequency	kHz	4	4	4	4	4
Efficiency η		> 0.97	> 0.97	> 0.97	> 0.97	> 0.97
Power loss (at rated current)	kW	0.4	0.42	0.52	0.69	0.99
Cooling air requirement	m ³ /s	0.055	0.055	0.055	0.055	0.055
Sound pressure level L_{pA} (1 m)	dB	< 60	< 60	< 60	< 61	< 60
24 V DC power supply for Control Unit	A	1	1	1	1	1
Rated input current³⁾						
• with line reactor	A	33	40	47	63	78
• without line reactor	A	39	46	53	72	88
Max. length of cable to braking resistor	m	15	15	15	15	15
Line supply connection U1/L1, V1/L2, W1/L3		Screw terminals				
• Conductor cross-section	mm ²	2.5 ... 10	10 ... 50	10 ... 50	10 ... 50	10 ... 50
Motor connection U2, V2, W2		Screw terminals				
• Conductor cross-section	mm ²	2.5 ... 10	10 ... 50	10 ... 50	10 ... 50	10 ... 50
DC link connection, connection for the braking resistor DCP/R1, DCN, R2		Screw terminals				
• Conductor cross-section	mm ²	2.5 ... 10	10 ... 50	10 ... 50	10 ... 50	10 ... 50
PE connection		On housing with M5 screw				
Motor cable length⁴⁾, max.		On housing with M6 screw				
• Shielded	m	50	50	50	50	100
• Unshielded	m	100	100	100	100	100
Degree of protection		IP20				
Dimensions						
• Width	mm	189	275	275	275	275
• Height						
- without integrated filter	mm	334	419	419	419	499
- with integrated filter	mm	334	512	512	512	635
• Depth						
- without Control Unit	mm	185	204	204	204	204
- with Control Unit	mm	250	260	260	260	260
Frame size		FSC				
Weight, approx.		FSD				
• without integrated filter	kg	7	13	13	13	16
• with integrated filter	kg	7	16	16	16	23

¹⁾ The rated output current I_{rated} and the base load current I_L are based on the duty cycle for light overload (LO).

²⁾ The base load current I_H is based on the duty cycle for high overload (HO).

³⁾ The input current depends on the motor load and line impedance. The input currents apply for a load at rated power (based on I_{rated}) for a line impedance corresponding to $u_K = 1\%$. These current values without line reactor are stamped on the rating plate of the Power Module.

⁴⁾ Max. motor cable length 25 m (shielded) for PM240 Power Modules with integrated line filter to maintain the limit values of EN 61800-3 Category C2.

SINAMICS G120

Standard inverters 0.37 kW to 250 kW (0.5 hp to 400 hp)

PM240 Power Modules – 0.37 kW to 250 kW (0.5 hp to 400 hp)

Technical specifications

Line supply voltage 380 ... 480 V 3 AC		PM240 Power Modules					
Without integrated line filter		6SL3224-0BE33-7UA0	6SL3224-0BE34-5UA0	6SL3224-0BE35-5UA0	6SL3224-0BE37-5UA0	6SL3224-0BE38-8UA0	6SL3224-0BE41-1UA0
With integrated line filter		6SL3224-0BE33-7AA0	6SL3224-0BE34-5AA0	6SL3224-0BE35-5AA0	6SL3224-0BE37-5AA0	–	–
Output current at 50 Hz 400 V 3 AC							
• Rated current $I_{rated}^{1)}$	A	90	110	145	178	205	250
• Base load current $I_L^{1)}$	A	90	110	145	178	205	250
• Base load current $I_H^{2)}$	A	75	90	110	145	178	205
• I_{max}	A	150	180	220	290	308	375
Rated power							
• based on I_L	kW (hp)	45 (60)	55 (75)	75 (100)	90 (125)	110 (150)	132 (200)
• based on I_H	kW (hp)	37 (50)	45 (60)	55 (75)	75 (100)	90 (125)	110 (150)
Rated pulse frequency	kHz	4	4	4	4	2	2
Efficiency η		> 0.97	> 0.97	> 0.97	> 0.97	> 0.97	> 0.97
Power loss (at rated current)	kW	1.21	1.42	1.93	2.31	2.43	2.53
Cooling air requirement	m ³ /s	2 × 0.055	0.15	0.15	0.15	0.15	0.15
Sound pressure level L_{pA} (1 m)	dB	< 62	< 60	< 60	< 65	< 65	< 65
24 V DC power supply for Control Unit	A	1	1	1	1	1	1
Rated input current ³⁾							
• with line reactor	A	94	115	151	186	210	250
• without line reactor	A	105	129	168	204	245	299
Max. length of cable to braking resistor	m	15	15	15	15	15	15
Line supply connection U1/L1, V1/L2, W1/L3							
• Conductor cross-section	mm ²	10 ... 50	25 ... 120	25 ... 120	25 ... 120	25 ... 120	25 ... 120
Motor connection U2, V2, W2							
• Conductor cross-section	mm ²	10 ... 50	25 ... 120	25 ... 120	25 ... 120	25 ... 120	25 ... 120
DC link connection, connection for the braking resistor DCP/R1, DCN, R2							
• Conductor cross-section	mm ²	10 ... 50	25 ... 120	25 ... 120	25 ... 120	25 ... 120	25 ... 120
PE connection							
		On housing with M6 screw	On housing with M8 screw	On housing with M8 screw	On housing with M8 screw	On housing with M8 screw	On housing with M8 screw
Motor cable length ⁴⁾, max.							
• Shielded	m	100	150	150	150	150	150
• Unshielded	m	100	150	150	150	150	150
Degree of protection							
		IP20	IP20	IP20	IP20	IP20	IP20
Dimensions							
• Width	mm	275	350	350	350	350	350
• Height							
- without integrated filter	mm	499	634	634	634	634	634
- with integrated filter	mm	635	934	934	934	–	–
• Depth							
- without Control Unit	mm	204	316	316	316	316	316
- with Control Unit	mm	260	372	372	372	372	372
Frame size							
		FSE	FSF	FSF	FSF	FSF	FSF
Weight, approx.							
• without integrated filter	kg	16	36	36	36	39	39
• with integrated filter	kg	23	52	52	52	–	–

¹⁾ The rated output current I_{rated} and the base load current I_L are based on the duty cycle for light overload (LO).

²⁾ The base load current I_H is based on the duty cycle for high overload (HO).

³⁾ The input current depends on the motor load and line impedance. The input currents apply for a load at rated power (based on I_{rated}) for a line impedance corresponding to $u_K = 1\%$. These current values without line reactor are stamped on the rating plate of the Power Module.

⁴⁾ Max. motor cable length 25 m (shielded) for PM240 Power Modules with integrated line filter to maintain the limit values of EN 61800-3 Category C2.

SINAMICS G120

Standard inverters 0.37 kW to 250 kW (0.5 hp to 400 hp)

PM240 Power Modules –
0.37 kW to 250 kW (0.5 hp to 400 hp)

Technical specifications

Line supply voltage 380 ... 480 V 3 AC		PM240 Power Modules		
Without integrated line filter		6SL3224-0XE41-3UA0	6SL3224-0XE41-6UA0	6SL3224-0XE42-0UA0
Output current at 50 Hz 400 V 3 AC				
• Rated current $I_{rated}^{1)}$	A	302	370	477
• Base load current $I_L^{1)}$	A	302	370	477
• Base load current $I_H^{2)}$	A	250	302	370
• I_{max}	A	400	483	592
Rated power				
• based on I_L	kW (hp)	160 (250)	200 (300)	250 (400)
• based on I_H	kW (hp)	132 (200)	160 (215)	200 (300)
Rated pulse frequency	kHz	2	2	2
Efficiency η		> 0.98	> 0.98	> 0.98
Power loss (at rated current)	kW	3.9	4.4	5.5
Cooling air requirement	m ³ /s	0.36	0.36	0.36
Sound pressure level L_{pA} (1 m)	dB	< 69	< 69	< 69
24 V DC power supply for Control Unit	A	1	1	1
Rated input current ³⁾				
• with line reactor	A	245	297	354
• without line reactor	A	297	354	442
Max. length of cable to braking resistor	m	50	50	50
Line supply connection U1/L1, V1/L2, W1/L3				
• Conductor cross-section	mm ²	2 × 240	2 × 240	2 × 240
Motor connection U2, V2, W2				
• Conductor cross-section	mm ²	2 × 240	2 × 240	2 × 240
PE connection		On housing with M10 screw	On housing with M10 screw	On housing with M10 screw
Motor cable length ⁴⁾, max.				
• Shielded	m	300	300	300
• Unshielded	m	450	450	450
Degree of protection		IP20	IP20	IP20
Dimensions				
• Width	mm	326	326	326
• Height	mm	1533	1533	1533
• Depth	mm	547	547	547
Frame size		FSGX	FSGX	FSGX
Weight, approx.	kg	174	174	174

¹⁾ The rated output current I_{rated} and the base load current I_L are based on the duty cycle for light overload (LO).

²⁾ The base load current I_H is based on the duty cycle for high overload (HO).

³⁾ The input current depends on the motor load and line impedance. The input currents apply for a load at rated power (based on I_{rated}) for a line impedance corresponding to $u_K = 1\%$. These current values without line reactor are stamped on the rating plate of the Power Module.

⁴⁾ Max. motor cable length 25 m (shielded) for PM240 Power Modules with integrated line filter to maintain the limit values of EN 61800-3 Category C2.

SINAMICS G120

Standard inverters 0.37 kW to 250 kW (0.5 hp to 400 hp)

PM240 Power Modules – 0.37 kW to 250 kW (0.5 hp to 400 hp)

Characteristic curves

Derating data

Pulse frequency

Rated power at 400 V 3 AC		Rated output current in A at a pulse frequency of							
kW	hp	2 kHz	4 kHz	6 kHz	8 kHz	10 kHz	12 kHz	14 kHz	16 kHz
0.37	0.50	–	1.3	1.1	0.9	0.8	0.7	0.6	0.5
0.55	0.75	–	1.7	1.4	1.2	1.0	0.9	0.8	0.7
0.75	1.0	–	2.2	1.9	1.5	1.3	1.1	1.0	0.9
1.1	1.5	–	3.1	2.6	2.2	1.9	1.6	1.4	1.2
1.5	2.0	–	4.1	3.5	2.9	2.5	2.1	1.8	1.6
2.2	3.0	–	5.9	5.0	4.1	3.5	3.0	2.7	2.4
3.0	4.0	–	7.7	6.5	5.4	4.6	3.9	3.5	3.1
4.0	5.0	–	10.2	8.7	7.1	6.1	5.1	4.6	4.1
7.5	10	–	18.0	16.2	13.3	11.4	9.5	8.6	7.6
11.0	15	–	25.0	22.1	18.2	15.6	13.0	11.7	10.4
15.0	20	–	32.0	27.2	22.4	19.2	16.0	14.4	12.8
18.5	25	–	38.0	32.3	26.6	22.8	19.0	17.1	15.2
22.0	30	–	45.0	38.3	31.5	27.0	22.5	20.3	18.0
30.0	40	–	62.0	52.7	43.4	37.2	31.0	27.9	24.8
37.0	50	–	75.0	63.8	52.5	45.0	37.5	33.8	30.0
45.0	60	–	90.0	76.5	63.0	54.0	45.0	40.5	36.0
55.0	75	–	110.0	93.5	77.0	–	–	–	–
75.0	100	–	145.0	123.3	101.5	–	–	–	–
90.0	125	–	178.0	151.3	124.6	–	–	–	–
110.0	150	205.0 ¹⁾	178.0	–	–	–	–	–	–
132.0	200	250.0 ¹⁾	202.0	–	–	–	–	–	–
160.0	250	302.0 ¹⁾	250.0	–	–	–	–	–	–
200.0	300	370.0 ¹⁾	302.0	–	–	–	–	–	–
250.0	400	477.0 ¹⁾	370.0	–	–	–	–	–	–

¹⁾ The pulse frequency can be switched over from 4 kHz (default) to 2 kHz only for the light overload (LO) duty cycle.

Characteristic curves

Ambient temperature

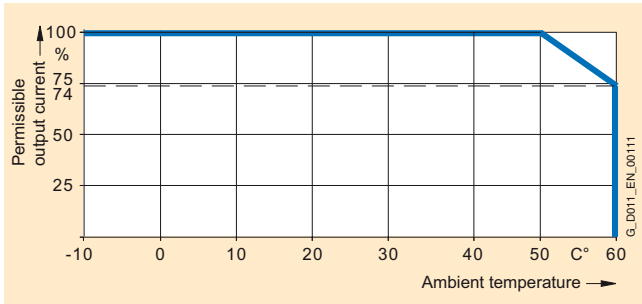

High overload (HO) PM240 Power Modules frame sizes FSD to FSF

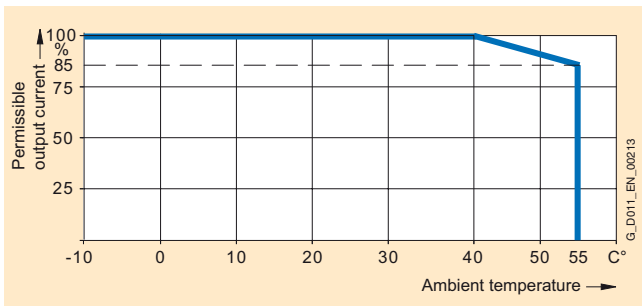

High overload (HO) PM240 Power Modules frame size FSGX

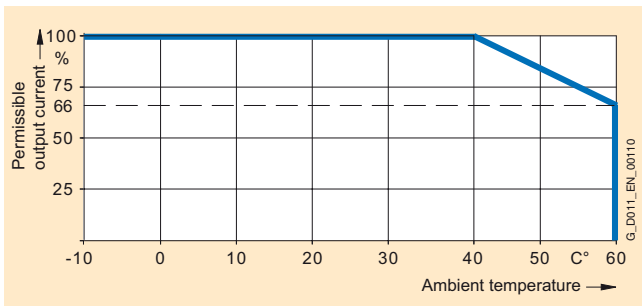

Light overload (LO) PM240 Power Modules frame sizes FSD to FSF

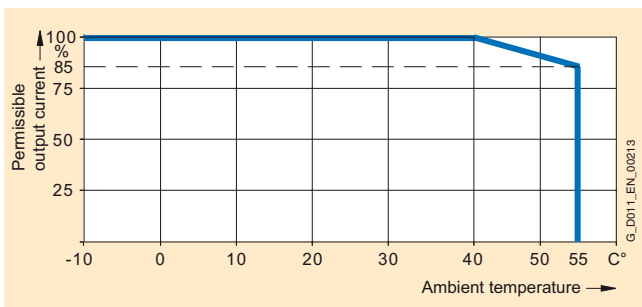

Light overload (LO) PM240 Power Modules frame size FSGX

Note: The operating temperature ranges of the Control Units should be taken into account. The temperature ranges are specified in the technical specifications under Control Units.

Installation altitude

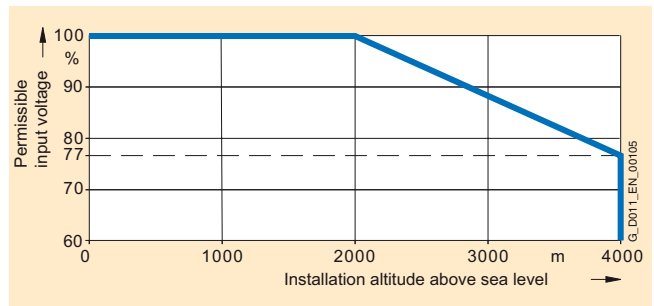
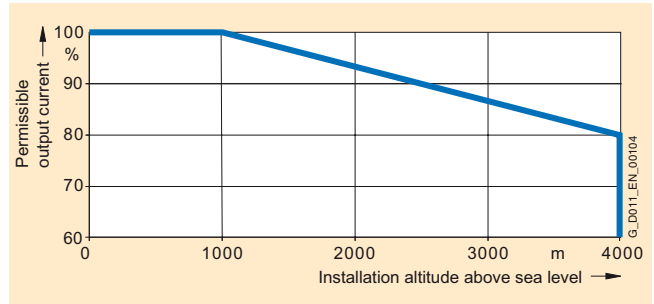

SINAMICS G120

Standard inverters 0.37 kW to 250 kW (0.5 hp to 400 hp)

PM240 Power Modules – 0.37 kW to 250 kW (0.5 hp to 400 hp)

Dimensional drawings

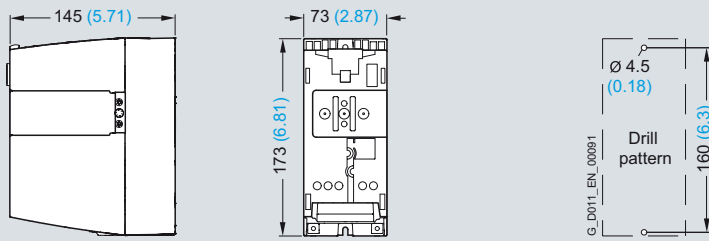

PM240 Power Module frame size FSA

Mounted with 2 M4 studs, 2 M4 nuts, 2 M4 washers.

Ventilation clearance required at top and bottom: 100 mm (3.94 inches).

Ventilation clearance required at sides:

- Ambient temperature ≤ 40 °C: 0 mm (0 inches).
- Ambient temperature > 40 °C: 30 mm (1.18 inches).

When the Control Unit is plugged on, the mounting depth increases by 65 mm (2.56 inches) and the total height by 14 mm (0.55 inches).

Exception: for CU240E, mounting depth +31 mm (+1.22 inches), total height +32 mm (+1.26 inches).

All dimensions in mm (values in brackets are in inches).

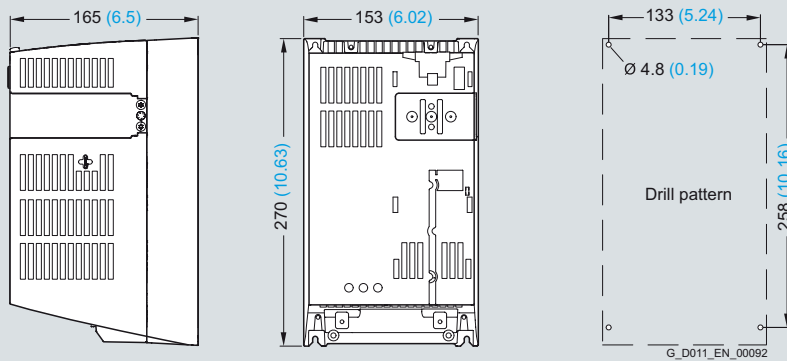

PM240 Power Module frame size FSB

Mounted with 4 M4 studs, 4 M4 nuts, 4 M4 washers.

Ventilation clearance required at top and bottom: 100 mm (3.94 inches).

Ventilation clearance required at sides:

- Ambient temperature ≤ 40 °C: 0 mm (0 inches).
- Ambient temperature > 40 °C: 40 mm (1.57 inches).

When the Control Unit is plugged on, the mounting depth increases by 65 mm (2.56 inches).

Exception: for CU240E, mounting depth +31 mm (+1.22 inches).

All dimensions in mm (values in brackets are in inches).

SINAMICS G120

Standard inverters 0.37 kW to 250 kW (0.5 hp to 400 hp)

PM240 Power Modules –
0.37 kW to 250 kW (0.5 hp to 400 hp)

Dimensional drawings

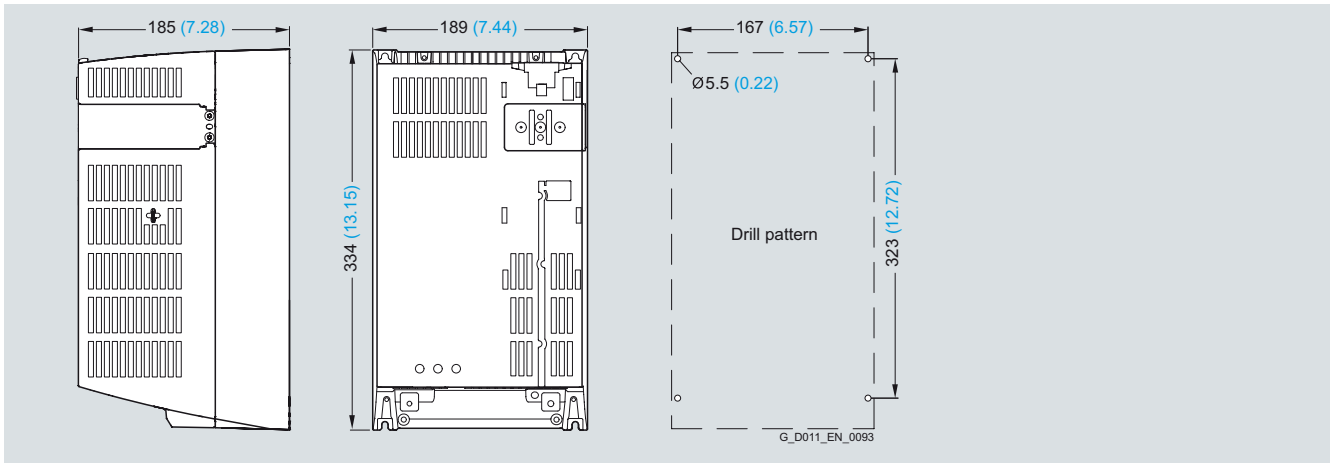

PM240 Power Module frame size FSC

Mounted with 4 M5 studs, 4 M5 nuts, 4 M5 washers.

Ventilation clearance required at top and bottom: 100 mm (3.94 inches).

Ventilation clearance required at sides:

- Ambient temperature ≤ 40 °C: 0 mm (0 inches).
- Ambient temperature > 40 °C: 50 mm (1.97 inches).

When the Control Unit is plugged on, the mounting depth increases by 65 mm (2.56 inches).

Exception: for CU240E, mounting depth +31 mm (+1.22 inches).

All dimensions in mm (values in brackets are in inches).

SINAMICS G120

Standard inverters 0.37 kW to 250 kW (0.5 hp to 400 hp)

PM240 Power Modules –
0.37 kW to 250 kW (0.5 hp to 400 hp)

Dimensional drawings

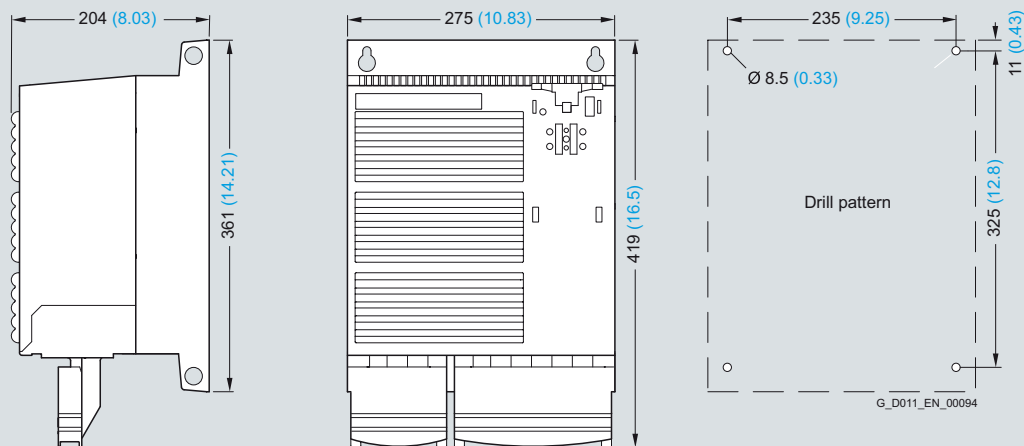

PM240 Power Module frame size FSD without line filter

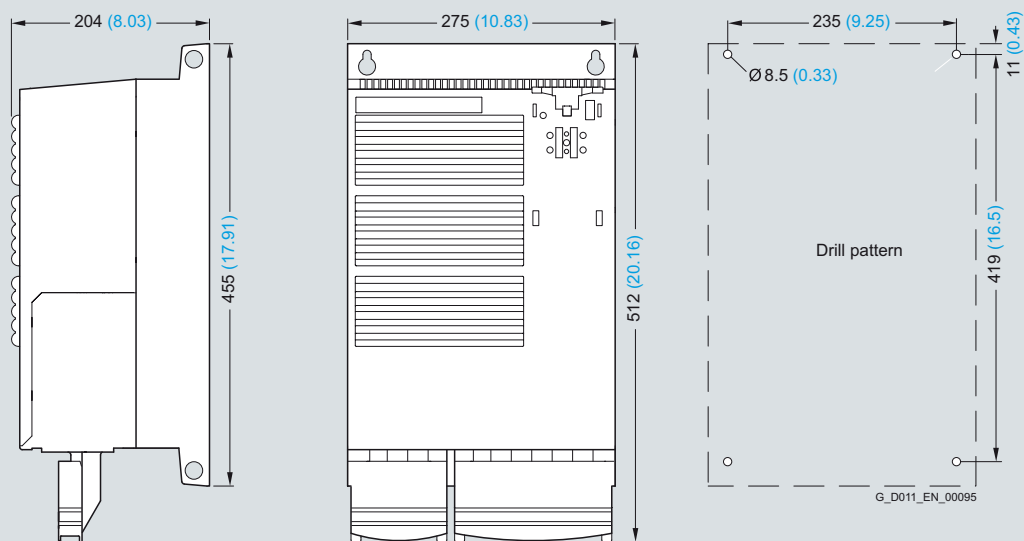

PM240 Power Module frame size FSD with integrated class A line filter

Mounted with 4 M8 studs, 4 M8 nuts, 4 M8 washers.

Ventilation clearance required at top and bottom: 300 mm (11.81 inches).

Ventilation clearance required at front: 28 mm (1.1 inches).

Ventilation clearance required at sides: 0 mm (0 inches).

When the Control Unit is plugged on, the mounting depth increases by 56 mm (2.2 inches).

Exception: for CU240E, mounting depth +22 mm (+0.87 inches).

All dimensions in mm (values in brackets are in inches).

SINAMICS G120

Standard inverters 0.37 kW to 250 kW (0.5 hp to 400 hp)

PM240 Power Modules –
0.37 kW to 250 kW (0.5 hp to 400 hp)

Dimensional drawings

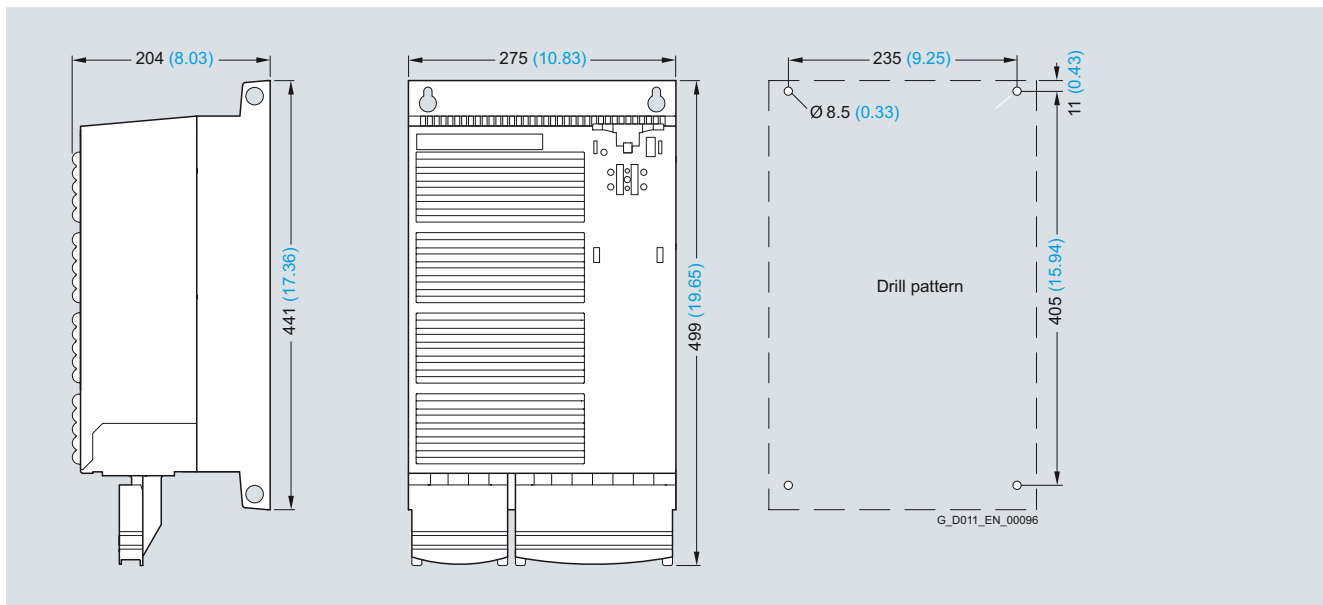

PM240 Power Module frame size FSE without line filter

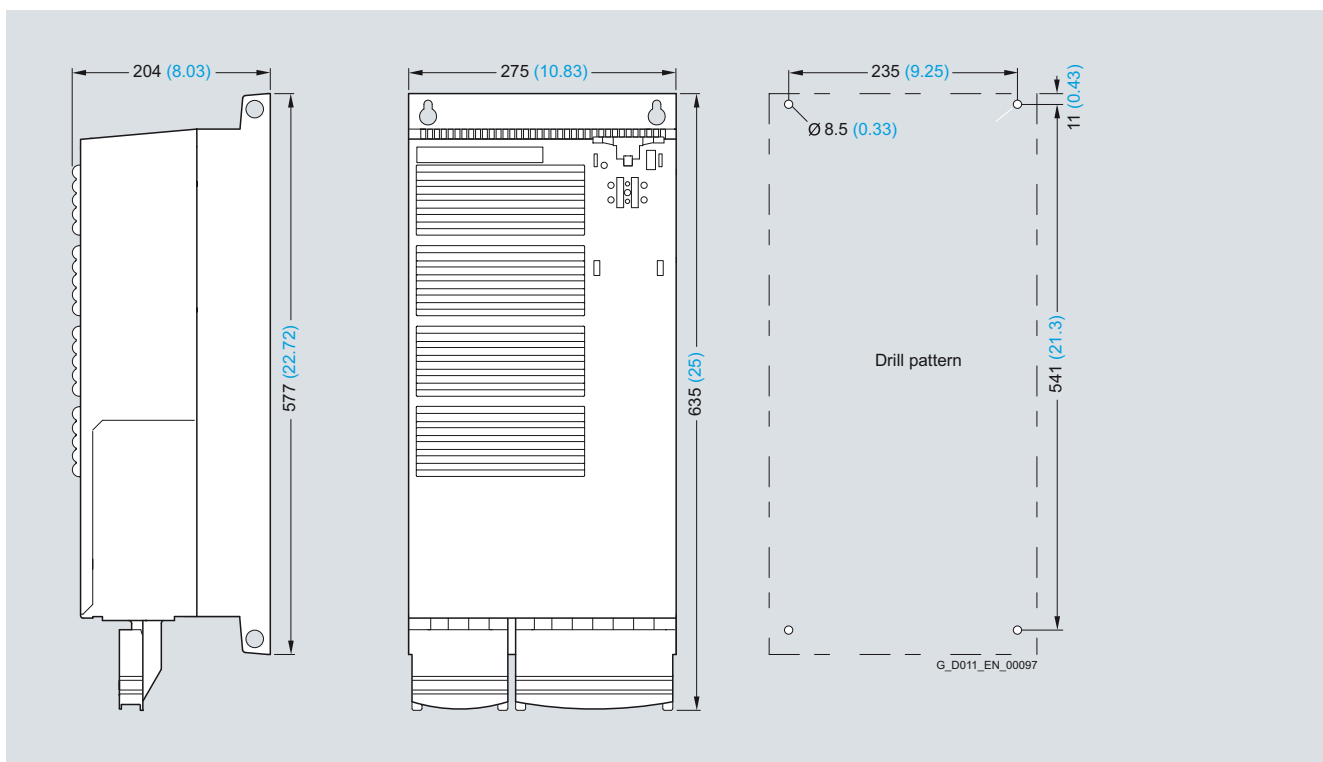

PM240 Power Module frame size FSE with integrated class A line filter

Mounted with 4 M8 studs, 4 M8 nuts, 4 M8 washers.

Ventilation clearance required at top and bottom: 300 mm (11.81 inches).

Ventilation clearance required at front: 28 mm (1.1 inches).

Ventilation clearance required at sides: 0 mm (0 inches).

When the Control Unit is plugged on, the mounting depth increases by 56 mm (2.2 inches).

Exception: for CU240E, mounting depth +22 mm (+0.87 inches).

All dimensions in mm (values in brackets are in inches).

SINAMICS G120

Standard inverters 0.37 kW to 250 kW (0.5 hp to 400 hp)

PM240 Power Modules –
0.37 kW to 250 kW (0.5 hp to 400 hp)

Dimensional drawings

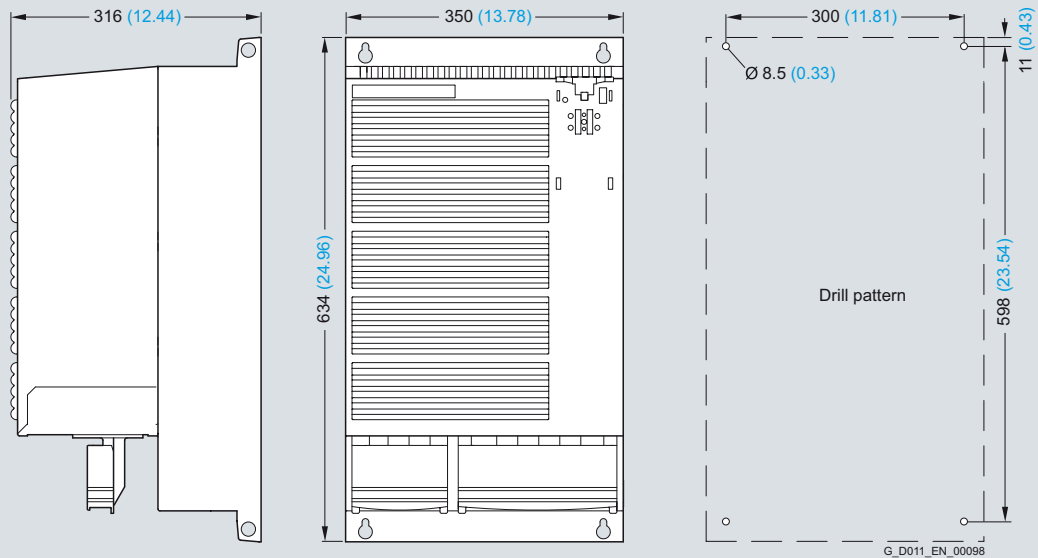

PM240 Power Module frame size FSF without line filter

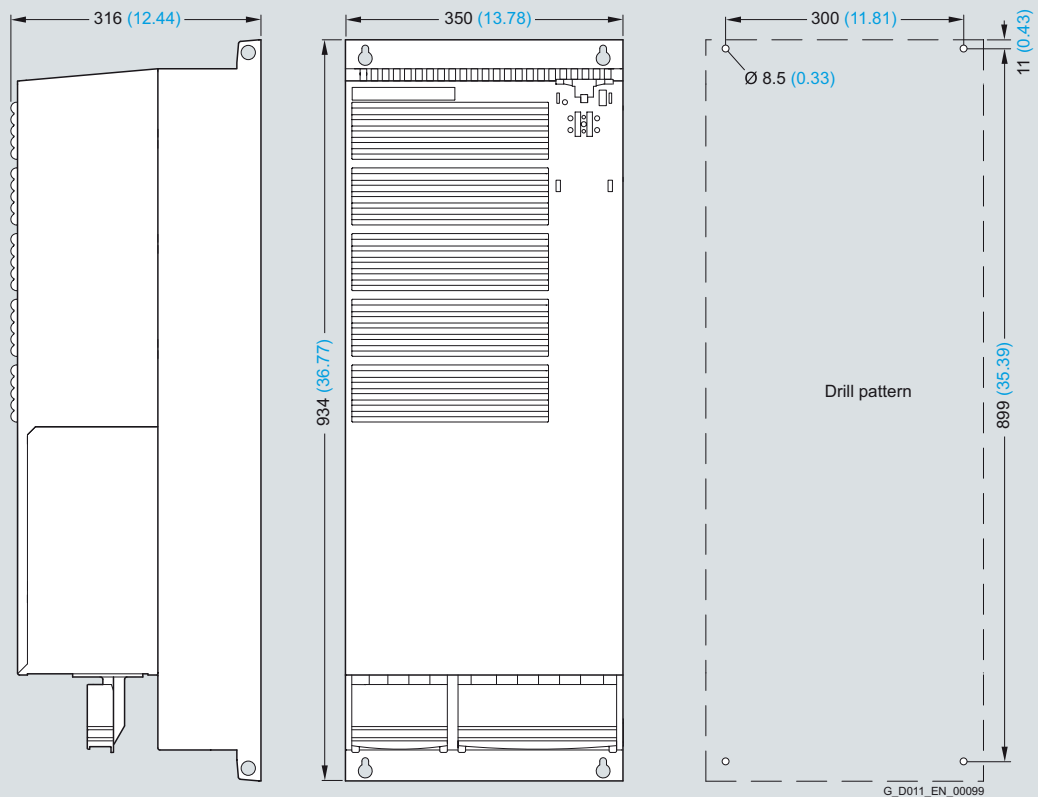

PM240 Power Module frame size FSF with integrated class A line filter

Mounted with 4 M8 studs, 4 M8 nuts, 4 M8 washers.

Ventilation clearance required at top and bottom: 350 mm
(13.78 inches).

Ventilation clearance required at front: 28 mm (1.1 inches).

Ventilation clearance required at sides: 0 mm (0 inches).

When the Control Unit is plugged on, the mounting depth increases by 56 mm (2.2 inches).

Exception: for CU240E, mounting depth +22 mm (+0.87 inches).

All dimensions in mm (values in brackets are in inches).

SINAMICS G120

Standard inverters 0.37 kW to 250 kW (0.5 hp to 400 hp)

PM240 Power Modules –
0.37 kW to 250 kW (0.5 hp to 400 hp)

Dimensional drawings

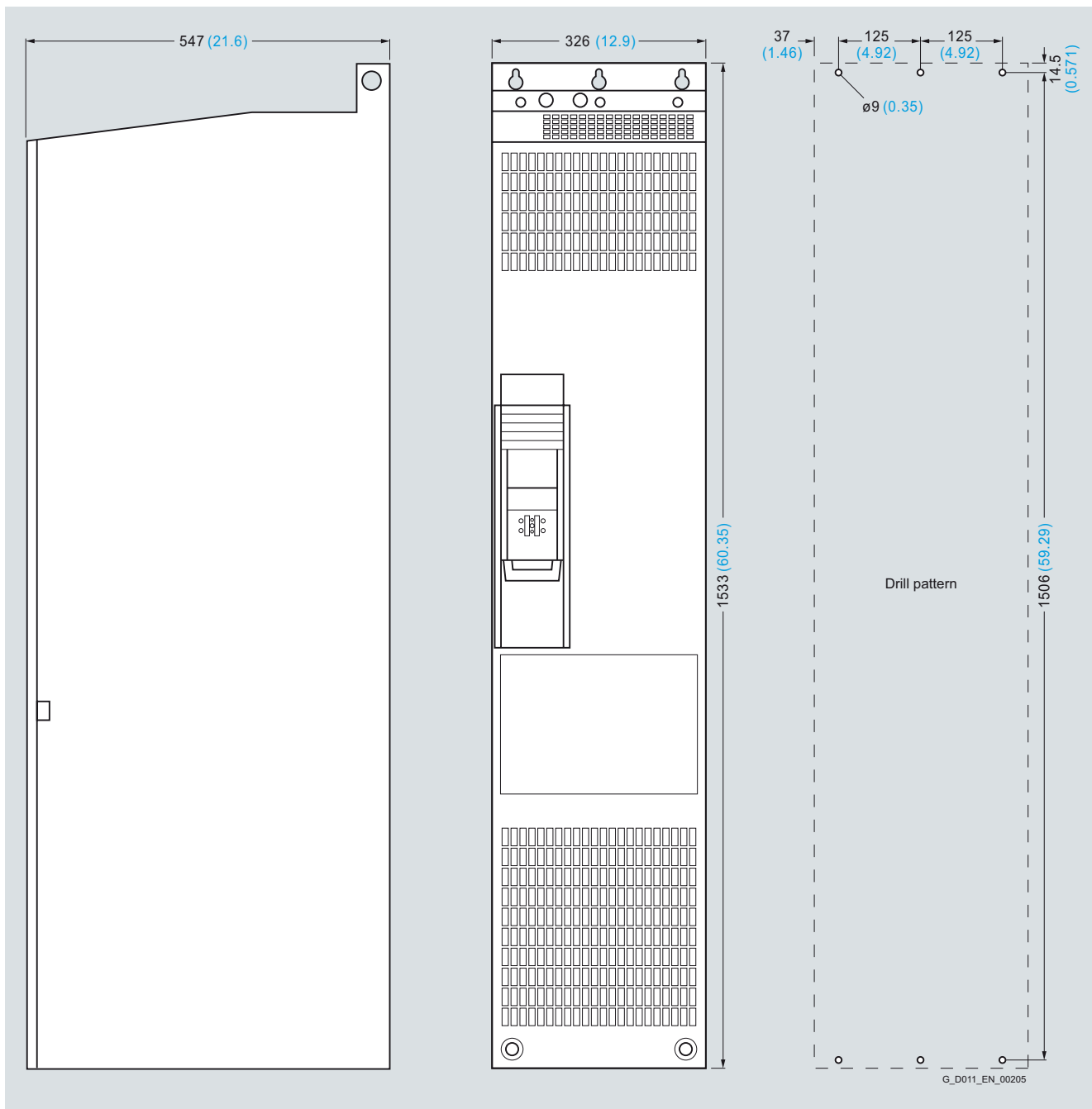

PM240 Power Module frame size FSGX without line filter

Mounted with 6 M8 studs, 6 M8 nuts, 6 M8 washers.

Ventilation clearance required at the top: 250 mm (9.84 inches).

Ventilation clearance required at the bottom: 150 mm (5.91 inches).

Ventilation clearance required at front: 50 mm (1.97 inches).

Ventilation clearance required at sides: 0 mm (0 inches).

When the Control Unit is plugged on, the mounting depth does not increase.

All dimensions in mm (values in brackets are in inches).

SINAMICS G120

Standard inverters 0.37 kW to 250 kW (0.5 hp to 400 hp)

PM250 Power Modules –
7.5 kW to 75 kW (10 hp to 100 hp)

Overview



Example: PM250 Power Modules frame sizes FSC to FSF

The PM250 Power Module features an absolutely unique technology – Efficient Infeed Technology. This feature provides the ability to feed energy back into the supply system in the generator mode (electronic braking) so that the energy is not wasted in a braking resistor. This saves space in the control cabinet. The time-consuming process of dimensioning the braking resistor and the expense of the extra wiring are eliminated. Furthermore, heat losses in the control cabinet are reduced.

The innovative circuit design used in Efficient Infeed Technology reduces the line harmonics. There is no need to use an optional line reactor at the supply infeed. This saves space and costs for engineering and procurement.

The PM250 Power Module is also suitable for use in safety-oriented applications. In conjunction with a Fail-safe Control Unit, the drive can be turned into a Safety Integrated Drive (see Control Units).

The permissible cable lengths between inverter and motor are limited. Longer cables can be used if output reactors are connected (see load-side power components).







Frame sizes FSD to FSF of the PM250 Power Modules are available both with as well as without integrated class A line filter.

For frame size FSC of PM250 Power Module with an integrated class A line filter, an additional class B base filter is available for achieving class B (see line-side power components).

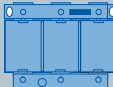
The PM250 Power Modules with integrated class A line filter are suitable for connection to TN supply systems. Power Modules without integrated line filter can be connected to grounded (TN, TT) and non-grounded (IT) supply systems.

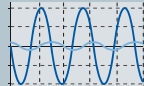
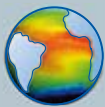
Overview of how customers benefit from Efficient Infeed Technology

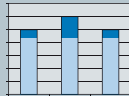
For more detailed information, please refer to the part Highlights, in section Efficient Infeed Technology.

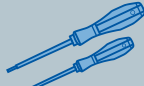
		Standard Technology	Efficient Infeed Technology
Line reactor		Required	Not required (+)
Braking resistor		Required	Not required (+)
Configuration overhead		Standard	Low (+)
Generated harmonics		Standard	Minimal (+)
Heat generated when braking		Yes	No (+)
Power infeed		Standard	Approx. 22% less (+)
Power consumption		Standard	Approx. 22% less (+)
Energy efficiency		Standard	Good (+)
Reactive power compensation		No	Yes (+)
Installation outlay		Standard	Low (+)

G_D011_EN_00182

SINAMICS G120

Standard inverters 0.37 kW to 250 kW (0.5 hp to 400 hp)

PM250 Power Modules –
7.5 kW to 75 kW (10 hp to 100 hp)

Selection and ordering data

To ensure that a suitable Power Module is selected, the following currents should be used for applications:

- **rated output current for applications with light overload (LO)**
- **base load current for applications with high overload (HO)**

With reference to the rated output current, the modules support at least 2-pole to 6-pole low-voltage motors, e.g. the new 1LE1 motor series (please refer to the Appendix for further information). The rated power is merely a guide value. For a description of the overload performance, please refer to the general technical specifications of the Power Modules.

Rated power ¹⁾		Rated output current ²⁾ I_{rated}	Power based on the base load current ³⁾		Base load current ³⁾ I_H	Frame size	SINAMICS G120 PM250 Power Module without integrated line filter	SINAMICS G120 PM250 Power Module with integrated class A line filter
kW	hp	A	kW	hp	A		Order No.	Order No.
380 ... 480 V 3 AC								
7.5	10	18	5.5	7.5	13.2	FSC	–	6SL3225-0BE25-5AA0
11.0	15	25	7.5	10	19	FSC	–	6SL3225-0BE27-5AA0
15.0	20	32	11.0	15	26	FSC	–	6SL3225-0BE31-1AA0
18.5	25	38	15.0	20	32	FSD	new	6SL3225-0BE31-5UA0
22	30	45	18.5	25	38	FSD	new	6SL3225-0BE31-8UA0
30	40	60	22	30	45	FSD	new	6SL3225-0BE32-2UA0
37	50	75	30	40	60	FSE	new	6SL3225-0BE33-0UA0
45	60	90	37	50	75	FSE	new	6SL3225-0BE33-7UA0
55	75	110	45	60	90	FSF	new	6SL3225-0BE34-5UA0
75	100	145	55	75	110	FSF	new	6SL3225-0BE35-5UA0
90	125	178	75	100	145	FSF	new	6SL3225-0BE37-5UA0

¹⁾ Rated power based on the rated output current I_{rated} . The rated output current I_{rated} is based on the duty cycle for light overload (LO).

²⁾ The rated output current I_{rated} is based on the duty cycle for light overload (LO). These current values are valid for 400 V and are stamped on the rating plate of the Power Module.

³⁾ The base load current I_H is based on the duty cycle for high overload (HO).

SINAMICS G120

Standard inverters 0.37 kW to 250 kW (0.5 hp to 400 hp)

PM250 Power Modules – 7.5 kW to 75 kW (10 hp to 100 hp)

Integration

PM250 Power Modules communicate with the Control Unit via the PM-IF interface.

PM250 Power Modules feature the following interfaces as standard:

- PM-IF interface to connect the PM250 Power Module to the Control Unit. The PM250 Power Module also supplies power to the Control Unit using an integrated power supply

- Motor connected using screw terminals or screw studs
- Control for the Brake Relay or the Safe Brake Relay for controlling a motor brake
- 2 PE/protective conductor connections

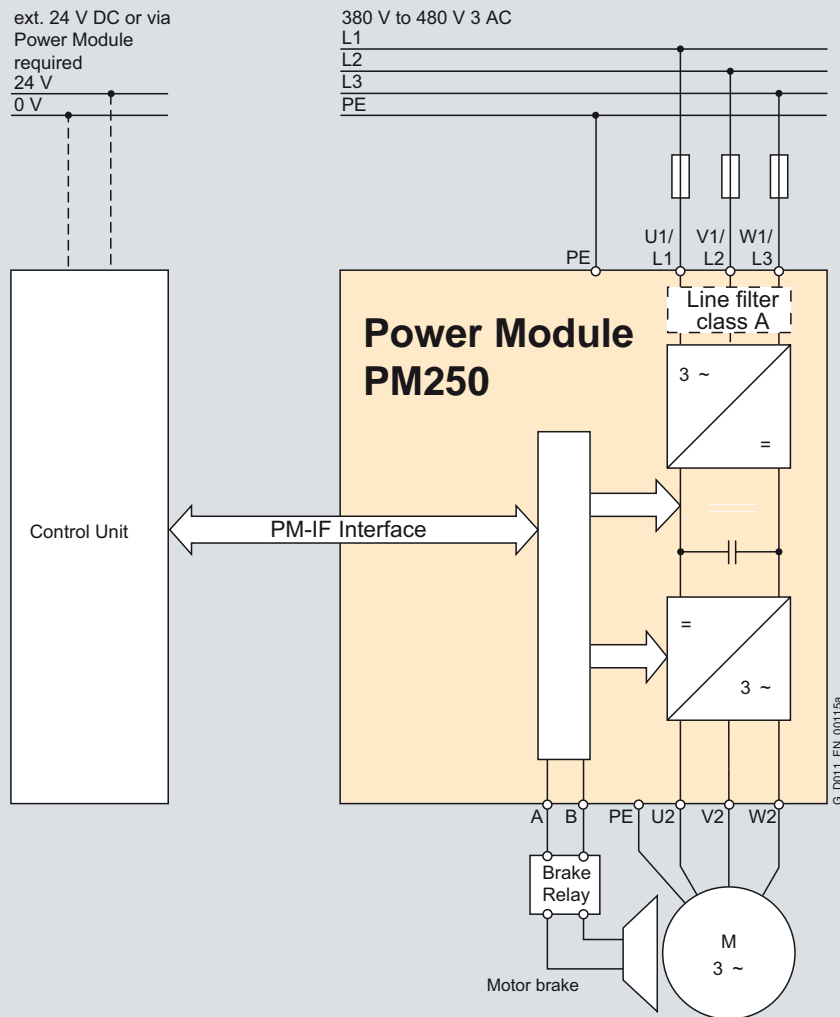

PM250 Power Module connection diagram with or without integrated class A line filter

Integration

Power and DC link components which are optionally available depending on the Power Module used

The following line-side power components, DC link components and load-side power components are optionally available in the appropriate frame sizes for the Power Modules:

	Frame size						
	FSA	FSB	FSC	FSD	FSE	FSF	FSGX
PM250 Power Module with line-commutated energy recovery							
Available frame sizes	–	–	✓	✓	✓	✓	–
Line-side power components							
Line filter, class A	–	–	I	F	F	F	–
Line filter, class B	–	–	U	–	–	–	–
Line reactor ¹⁾	–	–	– 1)	– 1)	– 1)	– 1)	–
DC link components							
Braking resistor ²⁾	–	–	– 2)	– 2)	– 2)	– 2)	–
Load-side power components							
Output reactor	–	–	U	S	S	S	–
Sine-wave filter	–	–	U	S	S	S	–

U = Base component

S = Lateral mounting

I = Integrated

– = Not possible

F = Power Modules available with and without integrated class A filter

Available as base components

Many system components for PM250 Power Modules are designed as base components, that is, the component is mounted on the baseplate and the PM250 Power Module above it in a space-saving design. Up to two base components can be mounted above one another.

The following diagram shows the basic layout of a PM250 Power Module with additional class B line filter as base component:

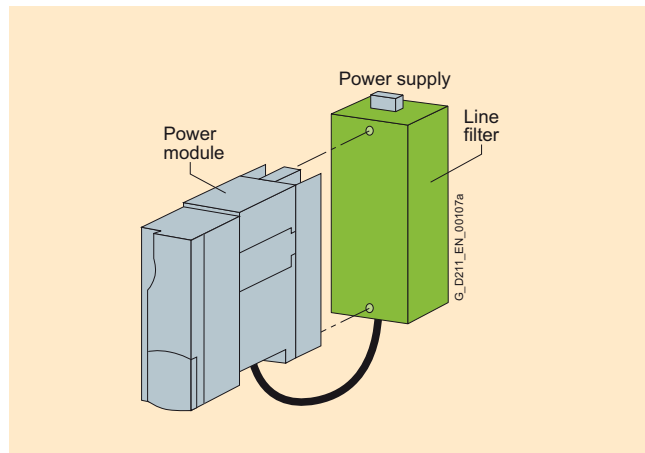

Basic layout of a PM250 Power Module with class B line filter as base component

The following example shows the structure for two base components:

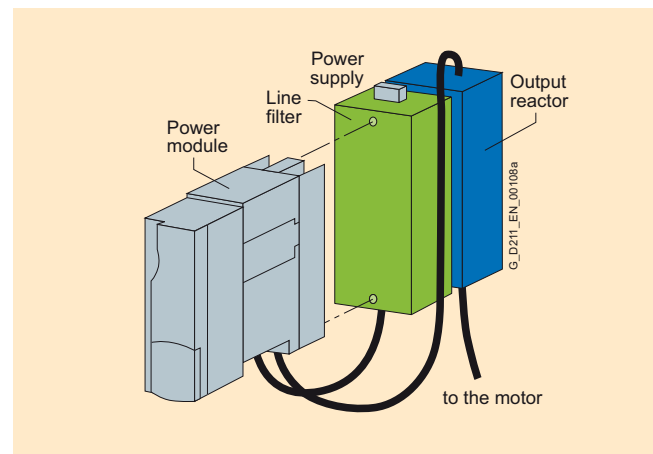

Basic layout of a PM250 Power Module with class B line filter as base component and output reactor

¹⁾ A line reactor is not required and must not be used in conjunction with a PM250 or PM260 Power Module.

²⁾ Line-commutated energy recovery is possible in conjunction with a PM250 or PM260 Power Module. A braking resistor cannot be connected and is not necessary.

SINAMICS G120

Standard inverters 0.37 kW to 250 kW (0.5 hp to 400 hp)

PM250 Power Modules – 7.5 kW to 75 kW (10 hp to 100 hp)

Integration

Maximum permissible cable lengths from the motor to the inverter when using output reactors or sine-wave filters depending on the voltage range

The following load-side power components in the appropriate frame sizes are optionally available for the Power Modules and result in the following maximum cable lengths:

	Maximum permissible motor cable lengths (shielded/unshielded) in m						
	Frame sizes						
	FSA	FSB	FSC	FSD	FSE	FSF	FSGX
PM250 Power Module with line-commutated energy recovery							
Available frame sizes	–	–	✓	✓	✓	✓	–
Without output reactor/sine-wave filter	–	–	50/100	50/100	50/100	50/100	–
With optional output reactor							
• at 380 V (–10 %) to 400 V 3 AC	–	–	150/225	200/300	200/300	200/300	–
• at 401 V to 480 V (+10 %) 3 AC	–	–	100/150	200/300	200/300	200/300	–
With optional sine-wave filter							
• at 380 V (–10 %) to 400 V 3 AC	–	–	200/300	200/300	200/300	200/300	–
• at 401 V to 480 V (+10 %) 3 AC	–	–	200/300	200/300	200/300	200/300	–

Derating data

The following inverter output currents can still be implemented for long motor cables without output reactor and sine-wave filter.

Derating for PM250 Power Modules, frame sizes FSC to FSF for shielded motor cables. From frame size FSD and higher, only the particular main Power Module types were tested. The values also apply to the other Power Modules of the particular frame size.

Rated power (at I_H)		Frame size	Base load current I_H	Rated output current I_{rated}	Motor connection cross-section	Current derating			
kW	hp					of the output current as a % of the base load current for the cable lengths (MOTION-CONNECT)			
			A	A	mm ²	50 m	100 m	150 m	200 m
5.5	7.5	FSC	13.2	18	10	100 %	70 %	45 %	–
7.5	10	FSC	19	25	10	100 %	90 %	80 %	–
11.0	15	FSC	26	32	10	100 %	90 %	80 %	–
22.0	30	FSD	45	60	35	100 %	95 %	90 %	85 %
37.0	50	FSE	75	90	35	100 %	100 %	95 %	90 %
75.0	100	FSF	145	178	95	100 %	100 %	100 %	95 %

– Not possible

Technical specifications

General technical specifications

	PM250 Power Modules
System operating voltage	380 ... 480 V 3 AC ±10 %
Line supply requirements	≤ 1 %
Line short circuit voltage u_K	
Input frequency	47 ... 63 Hz
Output frequency	
• Control type V/f	0 ... 650 Hz
• Control type Vector	0 ... 200 Hz
Pulse frequency	4 kHz (standard), higher pulse frequencies up to 16 kHz, see the derating data
Power factor	0.9
Inverter efficiency	95 ... 97 %
Modulation depth	87 %
Overload capability	
• High overload (HO)	1.5 × rated output current (i.e. 150 % overload) for 57 s with a cycle time of 300 s 2 × rated output current (i.e. 200 % overload) for 3 s with a cycle time of 300 s
• Light overload (LO)	1.1 × rated output current (i.e. 110 % overload) for 57 s with a cycle time of 300 s 1.5 × rated output current (i.e. 150 % overload) for 3 s with a cycle time of 300 s
Electromagnetic compatibility	Optional class A or B line filter acc. to EN 55011 is available
Possible braking methods	Energy recovery in the generator mode
Degree of protection	IP20
Operating temperature	
• High overload (HO)	0 ... 50 °C (32 ... 122 °F) without derating, > 50 ... 60 °C see derating characteristics
• Light overload (LO)	0 ... 40 °C (32 ... 104 °F) without derating, > 40 ... 60 °C see derating characteristics
Storage temperature	–40 ... +70 °C (–40 ... +158 °F)
Relative humidity	< 95 % RH, condensation not permissible
Cooling	Internal air cooling, power units with increased air cooling using integrated fans
Installation altitude	up to 1000 m above sea level without power reduction, > 1000 m see derating characteristics
Standard SCCR (Short Circuit Current Rating) ¹⁾	FSC: 10 kA FSD, FSE, FSF: 42 kA
Protection functions	<ul style="list-style-type: none"> • Undervoltage • Overvoltage • Overcontrol/overload • Ground fault • Short circuit • Stall protection • Motor blocking protection • Motor overtemperature • Inverter overtemperature • Parameter locking
Standards conformance	UL, cUL, CE, c-tick
CE mark	According to Low-Voltage Directive 73/23/EEC and Machinery Directive 98/37/EC

¹⁾ Applies to industrial control cabinet installations to NEC Article 409/UL 508A. For further information, visit us on the Internet at: <http://support.automation.siemens.com/WW/view/en/23995621>

SINAMICS G120

Standard inverters 0.37 kW to 250 kW (0.5 hp to 400 hp)

PM250 Power Modules – 7.5 kW to 75 kW (10 hp to 100 hp)

Technical specifications

Line supply voltage 380 ... 480 V 3 AC		PM250 Power Modules		
With integrated line filter		6SL3225-0BE25-5AA0	6SL3225-0BE27-5AA0	6SL3225-0BE31-1AA0
Output current at 50 Hz 400 V 3 AC				
• Rated current $I_{rated}^{1)}$	A	18	25	32
• Base load current $I_L^{1)}$	A	18	25	32
• Base load current $I_H^{2)}$	A	13.2	19	26
• I_{max}	A	26.4	38	52
Rated power				
• based on I_L	kW (hp)	7.5 (10)	11 (15)	15 (20)
• based on I_H	kW (hp)	5.5 (7.5)	7.5 (10)	11 (15)
Rated pulse frequency	kHz	4	4	4
Efficiency η		0.95	0.95	0.95
Power loss (at rated current)	kW	0.26	0.28	0.31
Cooling air requirement	m ³ /s	0.038	0.038	0.038
Sound pressure level L_{pA} (1 m)	dB	Available soon	Available soon	Available soon
24 V DC power supply for Control Unit	A	1	1	1
Input current ³⁾				
• Rated current	A	18	25	32
• Current based on I_H	A	13.2	19	26
Line supply connection U1/L1, V1/L2, W1/L3				
• Conductor cross-section	mm ²	2.5 ... 10	2.5 ... 10	2.5 ... 10
Motor connection U2, V2, W2				
• Conductor cross-section	mm ²	2.5 ... 10	2.5 ... 10	2.5 ... 10
PE connection				
		On housing with M5 screw	On housing with M5 screw	On housing with M5 screw
Motor cable length, max. ⁴⁾				
• Shielded	m	50	50	50
• Unshielded	m	100	100	100
Degree of protection				
		IP20	IP20	IP20
Dimensions				
• Width	mm	189	189	189
• Height	mm	334	334	334
• Depth				
- without Control Unit	mm	185	185	185
- with Control Unit	mm	250	250	250
Frame size				
		FSC	FSC	FSC
Weight, approx.	kg	7.5	7.5	7.5

¹⁾ The rated output current I_{rated} and the base load current I_L are based on the duty cycle for light overload (LO).

²⁾ The base load current I_H is based on the duty cycle for high overload (HO).

³⁾ The input current depends on the motor load and is valid for a line impedance corresponding to $u_K = 1\%$. The rated input currents apply for a load at the rated power (based on I_{rated}) – these current values are specified on the rating plate.

SINAMICS G120

Standard inverters 0.37 kW to 250 kW (0.5 hp to 400 hp)

PM250 Power Modules –
7.5 kW to 75 kW (10 hp to 100 hp)

Technical specifications

Line supply voltage 380 ... 480 V 3 AC		PM250 Power Modules		
Without integrated line filter		6SL3225-0BE31-5UA0	6SL3225-0BE31-8UA0	6SL3225-0BE32-2UA0
With integrated line filter		6SL3225-0BE31-5AA0	6SL3225-0BE31-8AA0	6SL3225-0BE32-2AA0
Output current at 50 Hz 400 V 3 AC				
• Rated current $I_{rated}^{1)}$	A	38	45	60
• Base load current $I_L^{1)}$	A	38	45	60
• Base load current $I_H^{2)}$	A	32	38	45
• I_{max}	A	64	76	90
Rated power				
• based on I_L	kW (hp)	18.5 (25)	22 (30)	30 (40)
• based on I_H	kW (hp)	15 (20)	18.5 (25)	22 (30)
Rated pulse frequency	kHz	4	4	4
Efficiency η		> 0.97	> 0.97	> 0.97
Power loss (at rated current)	kW	0.42	0.52	0.68
Cooling air requirement	m ³ /s	0.022	0.022	0.039
Sound pressure level L_{pA} (1 m)	dB	< 60	< 60	< 61
24 V DC power supply for Control Unit	A	1	1	1
Input current ³⁾				
• Rated current	A	36	42	56
• based on I_H	A	30	36	42
Line supply connection U1/L1, V1/L2, W1/L3				
• Conductor cross-section	mm ²	10 ... 35	10 ... 35	10 ... 35
Motor connection U2, V2, W2				
• Conductor cross-section	mm ²	10 ... 35	10 ... 35	10 ... 35
PE connection				
		On housing with M6 screw	On housing with M6 screw	On housing with M6 screw
Motor cable length, max. ⁴⁾				
• Shielded	m	50	50	50
• Unshielded	m	100	100	100
Degree of protection				
		IP20	IP20	IP20
Dimensions				
• Width	mm	275	275	275
• Height				
- without integrated line filter	mm	419	419	419
- With integrated line filter	mm	512	512	512
• Depth				
- without Control Unit	mm	204	204	204
- with Control Unit	mm	260	260	260
Frame size				
		FSD	FSD	FSD
Weight, approx.				
• Without integrated line filter	kg	13	13	13
• With integrated line filter	kg	15	15	16

¹⁾ The rated output current I_{rated} and the base load current I_L are based on the duty cycle for light overload (LO).

²⁾ The base load current I_H is based on the duty cycle for high overload (HO).

³⁾ The input current depends on the motor load and is valid for a line impedance corresponding to $u_K = 1\%$. The rated input currents apply for a load at the rated power (based on I_{rated}) – these current values are specified on the rating plate.

⁴⁾ Max motor cable length 25 m (shielded) for PM250 Power Modules with integrated line filter to maintain the limit values of EN 61800-3 Category C2.

SINAMICS G120

Standard inverters 0.37 kW to 250 kW (0.5 hp to 400 hp)

PM250 Power Modules – 7.5 kW to 75 kW (10 hp to 100 hp)

Technical specifications

Line supply voltage 380 ... 480 V 3 AC		PM250 Power Modules				
Without integrated line filter		6SL3225-0BE33-0UA0	6SL3225-0BE33-7UA0	6SL3225-0BE34-5UA0	6SL3225-0BE35-5UA0	6SL3225-0BE37-5UA0
With integrated line filter		6SL3225-0BE33-0AA0	6SL3225-0BE33-7AA0	6SL3225-0BE34-5AA0	6SL3225-0BE35-5AA0	6SL3225-0BE37-5AA0
Output current at 50 Hz 400 V 3 AC						
• Rated current $I_{rated}^{1)}$	A	75	90	110	145	178
• Base load current $I_L^{1)}$	A	75	90	110	145	178
• Base load current $I_H^{2)}$	A	60	75	90	110	145
• I_{max}	A	120	150	180	220	290
Rated power						
• based on I_L	kW (hp)	37 (50)	45 (60)	55 (75)	75 (100)	90 (125)
• based on I_H	kW (hp)	30 (40)	37 (50)	45 (60)	55 (75)	75 (100)
Rated pulse frequency	kHz	4	4	4	4	4
Efficiency η		> 0.97	> 0.97	> 0.97	> 0.97	> 0.97
Power loss (at rated current)	kW	0.99	1.21	1.42	1.93	2.31
Cooling air requirement	m ³ /s	0.022	0.039	0.094	0.094	0.117
Sound pressure level L_{pA} (1 m)	dB	< 60	< 62	< 60	< 60	< 65
24 V DC power supply for Control Unit	A	1	1	1	1	1
Input current ³⁾						
• Rated current	A	70	84	102	135	166
• based on I_H	A	56	70	84	102	135
Line supply connection U1/L1, V1/L2, W1/L3						
• Max. conductor cross-sect.	mm ²	10 ... 50	10 ... 50	25 ... 120	25 ... 120	25 ... 120
Motor connection U2, V2, W2						
• Max. conductor cross-sect.	mm ²	10 ... 50	10 ... 50	25 ... 120	25 ... 120	25 ... 120
PE connection						
		On housing with M6 screw	On housing with M6 screw	On housing with M8 screw	On housing with M8 screw	On housing with M8 screw
Motor cable length, max. ⁴⁾						
• Shielded	m	50	50	50	50	50
• Unshielded	m	100	100	100	100	100
Degree of protection						
		IP20	IP20	IP20	IP20	IP20
Dimensions						
• Width	mm	275	275	350	350	350
• Height						
- without integrated line filter	mm	499	499	634	634	634
- With integrated line filter	mm	635	635	934	934	934
• Depth						
- without Control Unit	mm	204	204	316	316	316
- with Control Unit	mm	260	260	372	372	372
Frame size						
		FSE	FSE	FSF	FSF	FSF
Weight, approx.						
• Without integrated line filter	kg	14	14	35	35	35
• With integrated line filter	kg	21	21	51	51	51

¹⁾ The rated output current I_{rated} and the base load current I_L are based on the duty cycle for light overload (LO).

²⁾ The base load current I_H is based on the duty cycle for high overload (HO).

³⁾ The input current depends on the motor load and is valid for a line impedance corresponding to $u_K = 1\%$. The rated input currents apply for a load at the rated power (based on I_{rated}) – these current values are specified on the rating plate.

⁴⁾ Max motor cable length 25 m (shielded) for PM250 Power Modules with integrated line filter to maintain the limit values of EN 61800-3 Category C2.

Characteristic curves

Derating data

Pulse frequency

Rated power at 400 V 3 AC		Rated output current in A at a pulse frequency of						
kW	hp	4 kHz	6 kHz	8 kHz	10 kHz	12 kHz	14 kHz	16 kHz
7.5	10	18	12.5	11.9	10.6	9.2	7.9	6.6
11.0	15	25	18.1	17.1	15.2	13.3	11.4	9.5
15.0	20	32	24.7	23.4	20.8	18.2	15.6	13
18.5	25	38	32	27	23	19	17	15
22.0	30	45	38	32	27	23	20	18
30.0	40	60	51	42	36	30	27	24
37.0	50	75	64	53	45	38	34	30
45.0	60	90	77	63	54	45	41	36
55.0	75	110	94	77	–	–	–	–
75.0	100	145	123	102	–	–	–	–
90.0	125	178	151	125	–	–	–	–

Ambient temperature

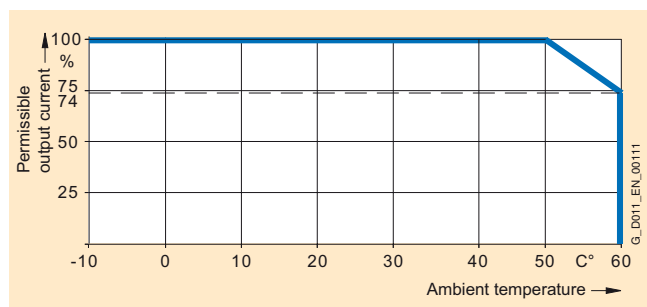

Installation altitude

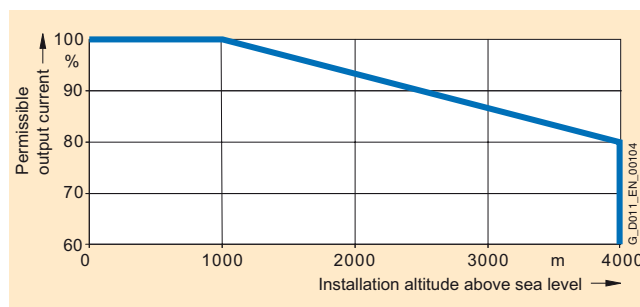

High overload (HO)

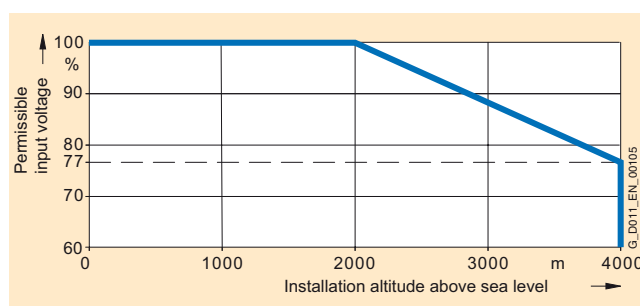
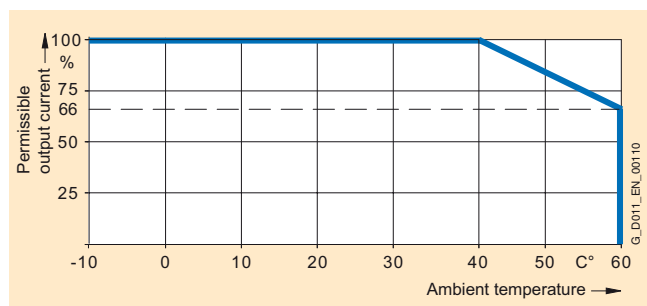

Light overload (LO)

Note: The operating temperature ranges of the Control Units should be taken into account. The temperature ranges are specified in the technical specifications under Control Units.

SINAMICS G120

Standard inverters 0.37 kW to 250 kW (0.5 hp to 400 hp)

PM250 Power Modules –
7.5 kW to 75 kW (10 hp to 100 hp)

Dimensional drawings

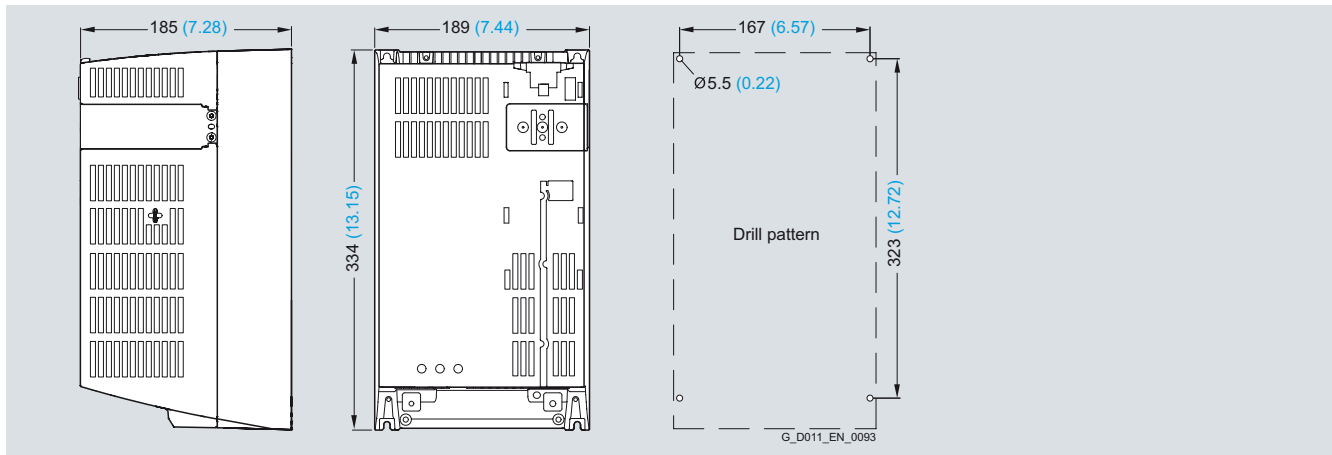

PM250 Power Module frame size FSC with integrated class A line filter

Mounted with 4 M5 studs, 4 M5 nuts, 4 M5 washers.

Ventilation clearance required at top and bottom: 125 mm (4.92 inches).

Ventilation clearance required at sides:

- Ambient temperature ≤ 40 °C: 0 mm (0 inches).
- Ambient temperature > 40 °C: 50 mm (1.97 inches).

When the Control Unit is plugged on, the mounting depth increases by 65 mm (2.56 inches).

Exception: for CU240E, mounting depth +31 mm (+1.22 inches).

All dimensions in mm (values in brackets are in inches).

SINAMICS G120

Standard inverters 0.37 kW to 250 kW (0.5 hp to 400 hp)

PM250 Power Modules –
7.5 kW to 75 kW (10 hp to 100 hp)

Dimensional drawings

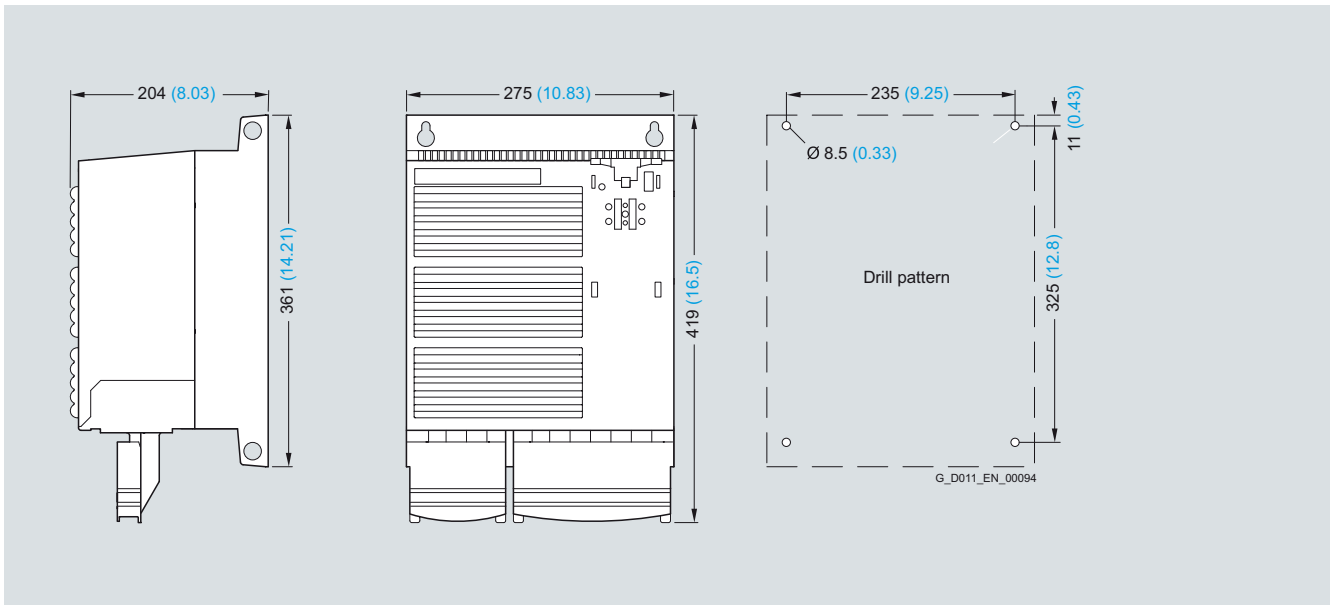

PM250 Power Module frame size FSD without line filter

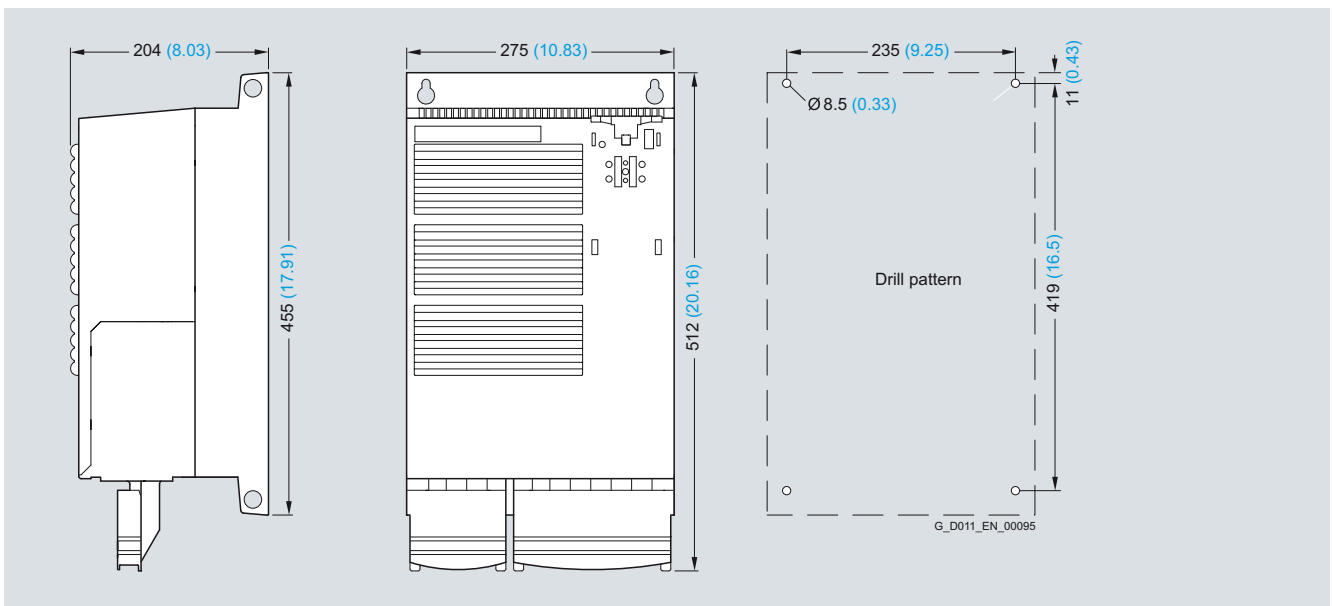

PM250 Power Module frame size FSD with integrated class A line filter

Mounted with 4 M8 studs, 4 M8 nuts, 4 M8 washers.

Ventilation clearance required at top and bottom: 300 mm (11.81 inches).

Ventilation clearance required at sides: 0 mm (0 inches).

When the Control Unit is plugged on, the mounting depth increases by 56 mm (2.2 inches).

Exception: for CU240E, mounting depth +22 mm (+0.87 inches).

All dimensions in mm (values in brackets are in inches).

SINAMICS G120

Standard inverters 0.37 kW to 250 kW (0.5 hp to 400 hp)

PM250 Power Modules –
7.5 kW to 75 kW (10 hp to 100 hp)

Dimensional drawings

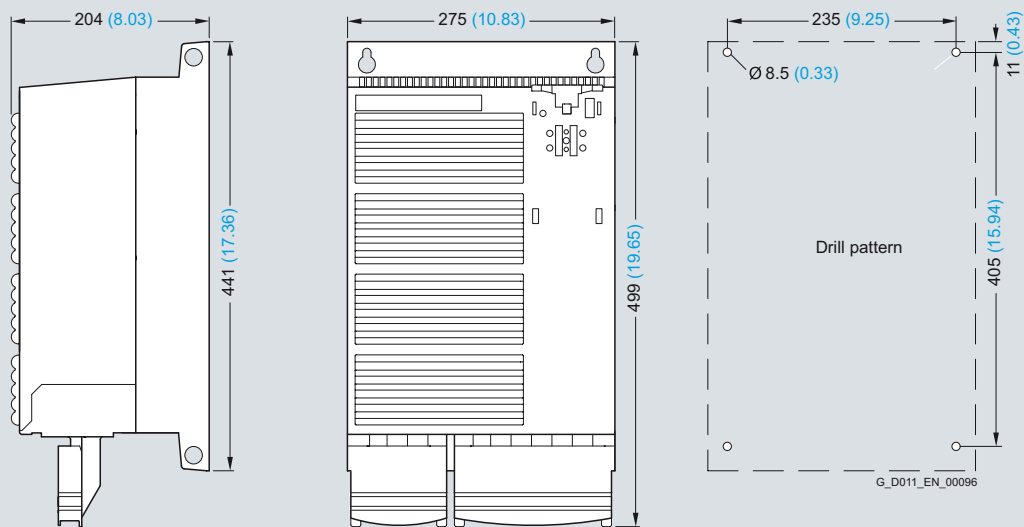

PM250 Power Module frame size FSE without line filter

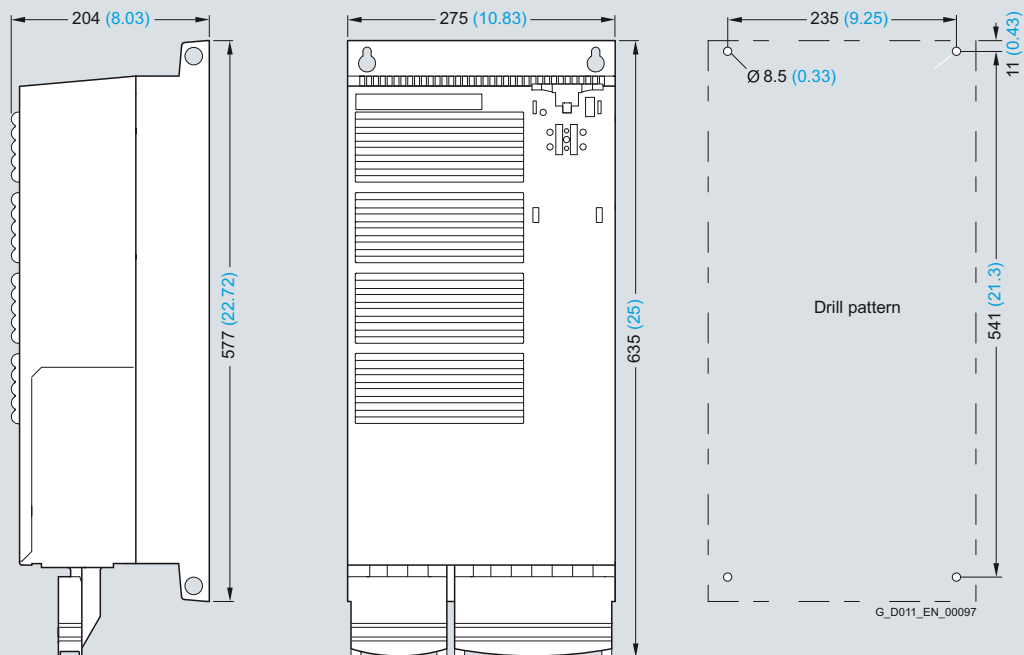

PM250 Power Module frame size FSE with integrated class A line filter

Mounted with 4 M8 studs, 4 M8 nuts, 4 M8 washers.

Ventilation clearance required at top and bottom: 300 mm (11.81 inches).

Ventilation clearance required at sides: 0 mm (0 inches).

When the Control Unit is plugged on, the mounting depth increases by 56 mm (2.2 inches).

Exception: for CU240E, mounting depth +22 mm (+0.87 inches).

All dimensions in mm (values in brackets are in inches).

SINAMICS G120

Standard inverters 0.37 kW to 250 kW (0.5 hp to 400 hp)

PM250 Power Modules –
7.5 kW to 75 kW (10 hp to 100 hp)

Dimensional drawings

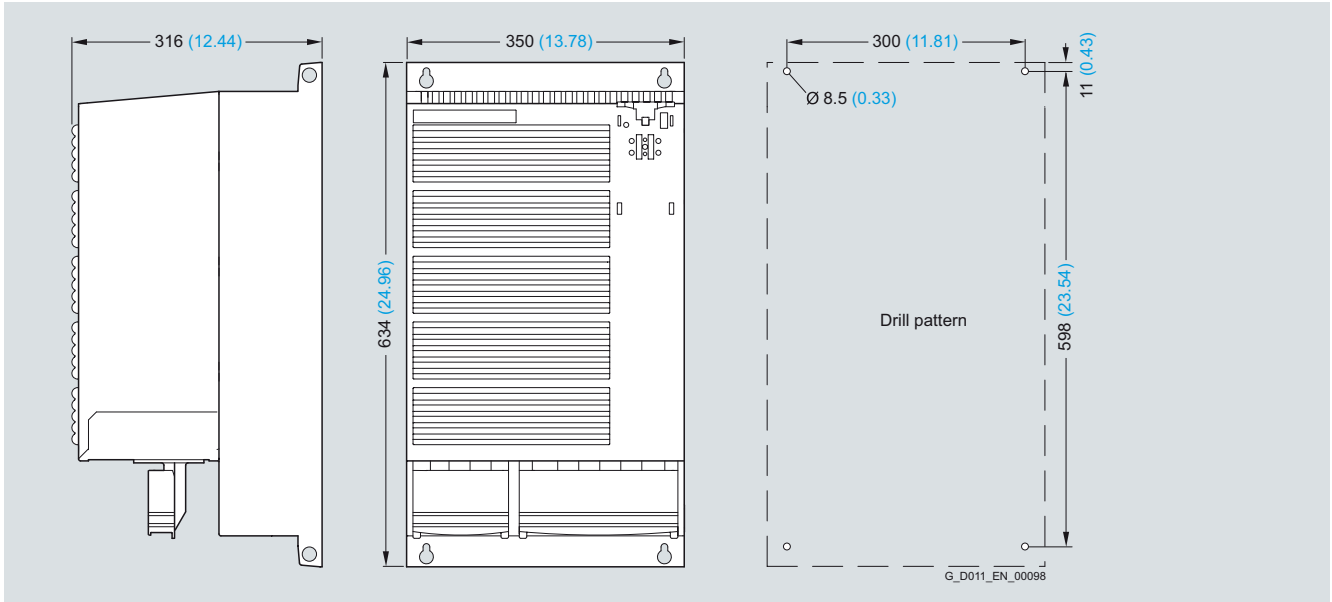

PM250 Power Module frame size FSF without line filter

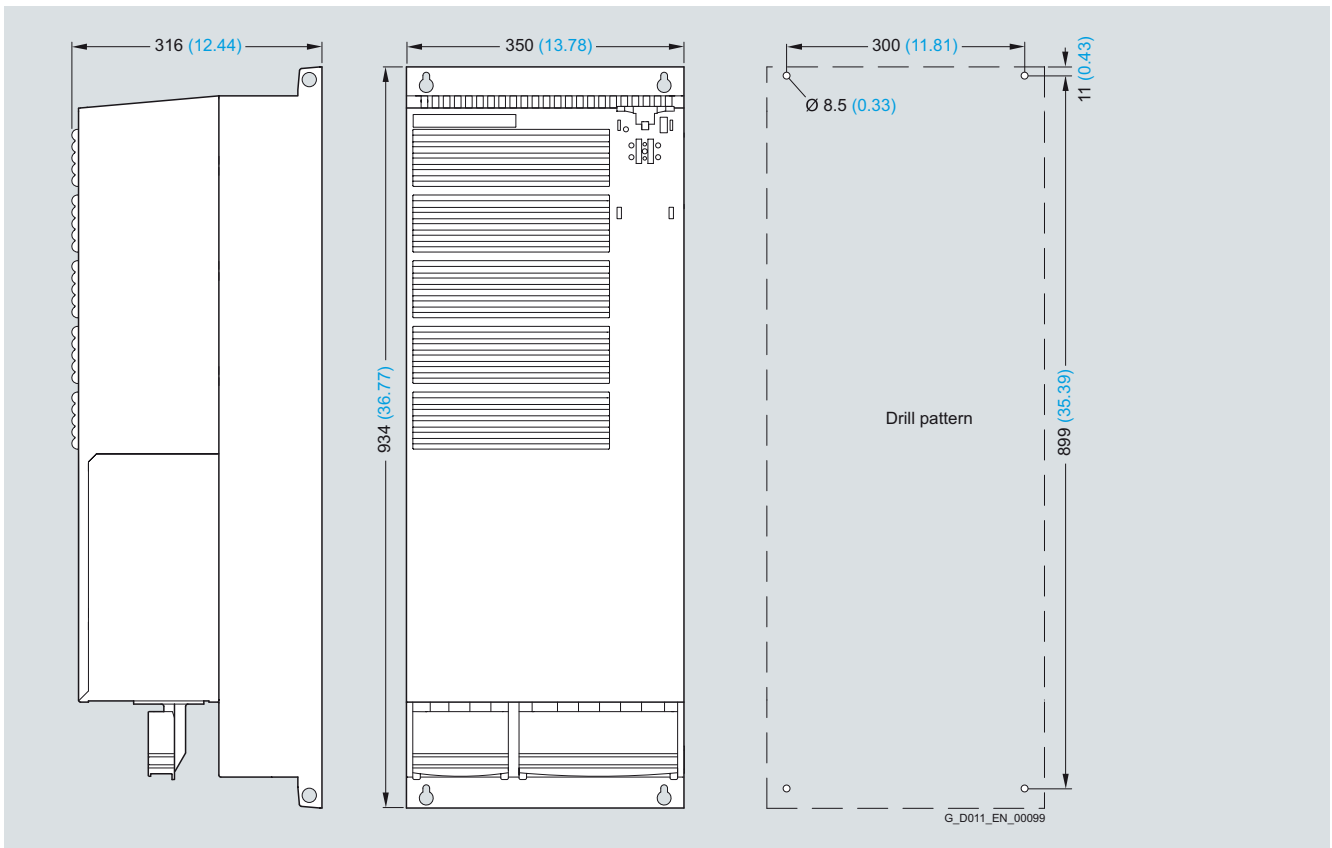

PM250 Power Module frame size FSF with integrated class A line filter

Mounted with 4 M8 studs, 4 M8 nuts, 4 M8 washers.

Ventilation clearance required at top and bottom: 350 mm
(13.78 inches).

Ventilation clearance required at sides: 0 mm (0 inches).

When the Control Unit is plugged on, the mounting depth increases by 56 mm (2.2 inches).

Exception: for CU240E, mounting depth +22 mm
(+0.87 inches).

All dimensions in mm (values in brackets are in inches).

SINAMICS G120

Standard inverters 0.37 kW to 250 kW (0.5 hp to 400 hp)

PM260 Power Modules –
11 kW to 55 kW (15 hp to 75 hp)

Overview



Example: PM260 FSD Power Module

The PM260 Power Module features an absolutely unique technology – Efficient Infeed Technology. This feature provides the ability to feed energy back into the supply system in the generator mode (electronic braking) so that the energy is not wasted in a braking resistor. This saves space in the control cabinet. The time-consuming process of dimensioning the braking resistor and the expense of the extra wiring are eliminated. Furthermore, heat losses in the control cabinet are reduced.

The innovative circuit design used in Efficient Infeed Technology reduces the line harmonics. There is no need to use an optional line reactor at the supply infeed. This saves space and costs for engineering and procurement.

The PM260 Power Modules are also characterized by a higher rated pulse frequency combined with a high efficiency and an integrated sine-wave filter. The integrated sine-wave filter ensures that the inverter output current is sinusoidal and supports cable lengths of up to 200 m shielded and 300 m unshielded. An output reactor is therefore not required. Furthermore, lower bearing currents and voltage stress are generated that reduces the overall stress on the motor.

The use of SiC free-wheeling diodes – an absolutely unique innovation – makes the PM260 Power Module extremely compact. It is also highly resistant to thermal loading and operates very quietly as a result of the high clock frequencies.







Standard motors can be used in conjunction with the PM260 Power Module. The winding system insulation strength does not have to be increased.

The PM260 Power Module is suitable for safety-oriented applications. In conjunction with a Fail-safe Control Unit, the drive can be turned into a Safety Integrated Drive (see Control Units).

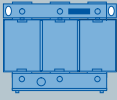
The PM260 Power Modules with integrated class A line filter are suitable for connection to TN supply systems. Power Modules without integrated line filter can be connected to grounded (TN, TT) and non-grounded (IT) supply systems.

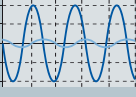
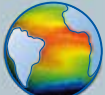
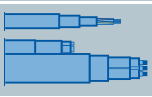
Overview of how customers benefit from Efficient Infeed Technology

For more detailed information, please refer to the part Highlights, in section Efficient Infeed Technology.

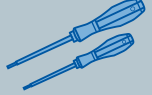
	Standard Technology	Efficient Infeed Technology
Line reactor 	Required	Not required +
Braking resistor 	Required	Not required +
Configuration overhead 	Standard	Low +
Generated harmonics 	Standard	Minimal +
Heat generated when braking 	Yes	No +
Power infeed 	Standard	Approx. 22% less +
Power consumption 	Standard	Approx. 22% less +
Energy efficiency 	Standard	Good +
Reactive power compensation 	No	Yes +
Installation outlay 	Standard	Low +

G_D011_EN_00182

Overview of how customers benefit from SiC free-wheeling diodes

- Low switching losses at high fundamental frequency
- High speeds possible
- Quiet operation thanks to pulse frequency = 16 kHz
- High thermal load capacity (small heatsinks)
- Very compact units
- Increased ruggedness
- High efficiency
- Low forward losses
- Power unit with regenerative feedback capability
- Integrated sine-wave filter, long unshielded cables can be used
- Can be used with motors without a special insulation
- Very low bearing currents, no bearing insulation required

SINAMICS G120

Standard inverters 0.37 kW to 250 kW (0.5 hp to 400 hp)













PM260 Power Modules –
11 kW to 55 kW (15 hp to 75 hp)

Selection and ordering data

To ensure that a suitable Power Module is selected, the following currents should be used for applications:

- **rated output current for applications with light overload (LO)**
- **base load current for applications with high overload (HO)**

With reference to the rated output current, the modules support at least 2-pole to 6-pole low-voltage motors, e.g. the new 1LE1 motor series (please refer to the Appendix for further information). The rated power is merely a guide value. For a description of the overload performance, please refer to the general technical specifications of the Power Modules.

Rated power ¹⁾		Rated output current ²⁾	Power based on the base load current ³⁾		Base load current ³⁾	Frame size	SINAMICS G120 PM260 Power Module without integrated line filter		SINAMICS G120 PM260 Power Module with integrated class A line filter	
kW	hp	A	kW	hp	A		Order No.		Order No.	
500 ... 690 V 3 AC										
11.0	15	14	7.5	10	10	FSD	 6SL3225-0BH27-5UA1	 6SL3225-0BH27-5AA1		
15.0	20	19	11	15	14	FSD	 6SL3225-0BH31-1UA1	 6SL3225-0BH31-1AA1		
18.5	25	23	15	20	19	FSD	 6SL3225-0BH31-5UA1	 6SL3225-0BH31-5AA1		
30	40	35	22	30	26	FSF	 6SL3225-0BH32-2UA1	 6SL3225-0BH32-2AA1		
37	50	42	30	40	35	FSF	 6SL3225-0BH33-0UA1	 6SL3225-0BH33-0AA1		
55	75	62	37	50	42	FSF	 6SL3225-0BH33-7UA1	 6SL3225-0BH33-7AA1		

¹⁾ Rated power based on the rated output current I_{rated} . The rated output current I_{rated} is based on the duty cycle for light overload (LO).

²⁾ The rated output current I_{rated} is based on the duty cycle for light overload (LO). These current values are valid for 690 V and are stamped on the rating plate of the Power Module.

³⁾ The base load current I_H is based on the duty cycle for high overload (HO).

SINAMICS G120

Standard inverters 0.37 kW to 250 kW (0.5 hp to 400 hp)

PM260 Power Modules – 11 kW to 55 kW (15 hp to 75 hp)

Integration

PM260 Power Modules communicate with the Control Unit via the PM-IF interface.

PM260 Power Modules feature the following interfaces as standard:

- PM-IF interface to connect the PM260 Power Module to the Control Unit. The PM260 Power Module also supplies power to the Control Unit using the integrated power supply

- Motor connected using screw terminals or screw studs
- Control for the Brake Relay or the Safe Brake Relay for controlling a motor brake
- 2 PE/protective conductor connections

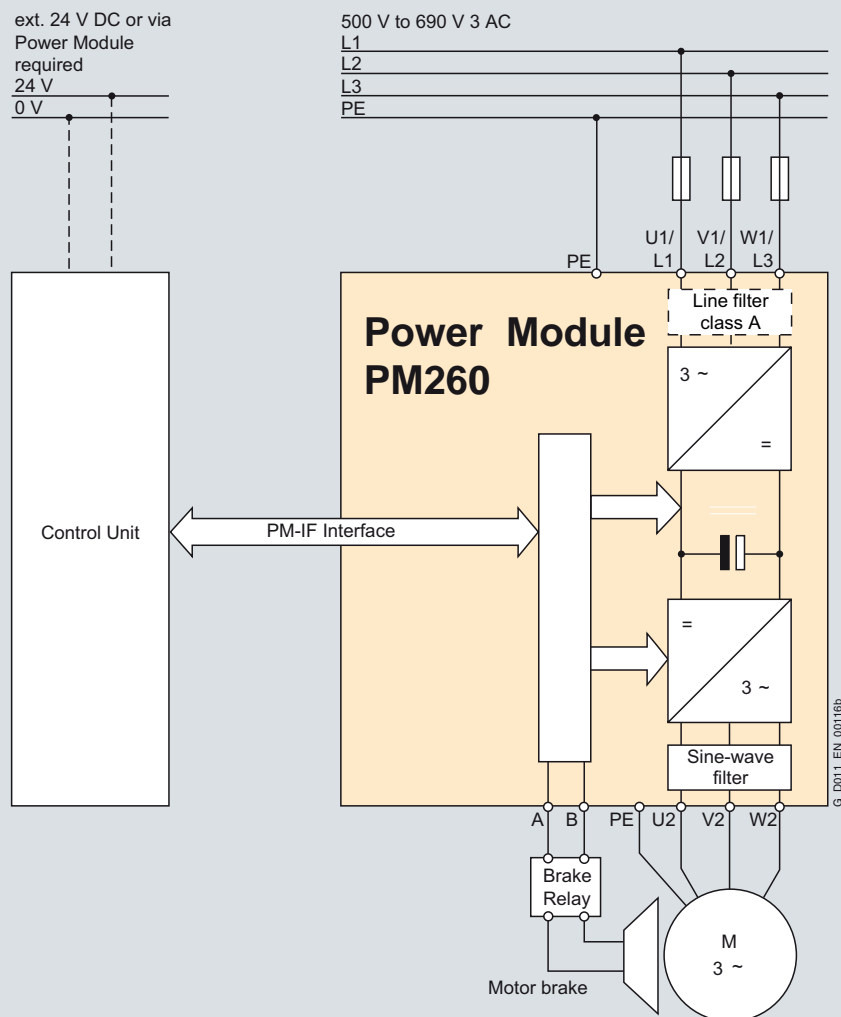

PM260 Power Module connection diagram with or without integrated class A line filter

Integration**Power and DC link components which are optionally available depending on the Power Module used**

The following line-side power components, DC link components and load-side power components are optionally available in the appropriate frame sizes for the Power Modules:

	Frame size						
	FSA	FSB	FSC	FSD	FSE	FSF	FSGX
PM260 Power Module with line-commutated energy recovery and integrated sine-wave filter							
Available frame sizes	–	–	–	✓	–	✓	–
Line-side power components							
Line filter, class A	–	–	–	F	–	F	–
Line filter, class B	–	–	–	–	–	–	–
Line reactor ¹⁾	–	–	–	– ¹⁾	–	– ¹⁾	–
DC link components							
Braking resistor ²⁾	–	–	–	– ²⁾	–	– ²⁾	–
Load-side power components							
Output reactor	–	–	–	–	–	–	–
Sine-wave filter	–	–	–	I	–	I	–

I = Integrated

– = Not possible

F = Power Modules available with and without integrated class A filter

Maximum permissible cable lengths from the motor to the inverter when using output reactors or sine-wave filters depending on the voltage range

The following load-side power components in the appropriate frame sizes are optionally available for the Power Modules and result in the following maximum cable lengths:

	Maximum permissible motor cable lengths (shielded/unshielded) in m						
	Frame sizes						
	FSA	FSB	FSC	FSD	FSE	FSF	FSGX
PM260 Power Module with line-commutated energy recovery and integrated sine-wave filter							
Available frame sizes	–	–	–	✓	–	✓	–
With integrated sine-wave filter							
• at 500 V to 690 V 3 AC (±10 %)	–	–	–	200/300	–	200/300	–

¹⁾ A line reactor is not required and must not be used in conjunction with a PM250 or PM260 Power Module.

²⁾ Line-commutated energy recovery is possible in conjunction with a PM250 or PM260 Power Module. A braking resistor cannot be connected and is not necessary.

SINAMICS G120

Standard inverters 0.37 kW to 250 kW (0.5 hp to 400 hp)

PM260 Power Modules –
11 kW to 55 kW (15 hp to 75 hp)

Technical specifications

General technical specifications

PM260 Power Modules	
System operating voltage	500 ... 690 V 3 AC $\pm 10\%$ For operation from 500 V -10% linearly reduced – see derating characteristics
Line supply requirements Line short circuit voltage u_K	$\leq 1\%$
Input frequency	47 ... 63 Hz
Output frequency	
• Control type V/f	0 ... 200 Hz
• Control type Vector	0 ... 200 Hz
Pulse frequency	16 kHz (standard)
Power factor	0.95
Inverter efficiency	95 ... 97 %
Modulation depth	87 %
Overload capability	
• High overload (HO)	1.5 \times rated output current (i.e. 150 % overload) for 57 s with a cycle time of 300 s 2 \times rated output current (i.e. 200 % overload) for 3 s with a cycle time of 300 s
• Light overload (LO)	1.1 \times rated output current (i.e. 110 % overload) for 57 s with a cycle time of 300 s 1.4 \times rated output current (i.e. 140 % overload) for 3 s with a cycle time of 300 s
Electromagnetic compatibility	Optional class A line filter according to EN 55011 is available
Possible braking methods	Energy recovery in the generator mode
Degree of protection	IP20
Operating temperature	
• High overload (HO)	0 ... 50 °C (32 ... 122 °F) without derating, > 50 ... 60 °C see derating characteristics
• Light overload (LO)	0 ... 40 °C (32 ... 104 °F) without derating, > 40 ... 60 °C see derating characteristics
Storage temperature	-40 ... +70 °C (-40 ... +158 °F)
Relative humidity	< 95 % RH, condensation not permissible
Cooling	Internal air cooling, power units with increased air cooling using integrated fans
Installation altitude	up to 1000 m above sea level without power reduction, > 1000 m see derating characteristics
Standard SCCR (Short Circuit Current Rating)¹⁾	42 kA
Protection functions	<ul style="list-style-type: none"> • Undervoltage • Overvoltage • Overcontrol/overload • Ground fault • Short circuit • Stall protection • Motor blocking protection • Motor overtemperature • Inverter overtemperature • Parameter locking
Standards conformance	CE
CE mark	According to Low-Voltage Directive 73/23/EEC and Machinery Directive 98/37/EC

¹⁾ Applies to industrial control cabinet installations to NEC Article 409/UL 508A. For further information, visit us on the Internet at: <http://support.automation.siemens.com/WW/view/en/23995621>

SINAMICS G120

Standard inverters 0.37 kW to 250 kW (0.5 hp to 400 hp)

PM260 Power Modules –
11 kW to 55 kW (15 hp to 75 hp)

Technical specifications

Line supply voltage 500 ... 690 V 3 AC		PM260 Power Modules		
Without integrated line filter		6SL3225-0BH27-5UA1	6SL3225-0BH31-1UA1	6SL3225-0BH31-5UA1
With integrated line filter		6SL3225-0BH27-5AA1	6SL3225-0BH31-1AA1	6SL3225-0BH31-5AA1
Output current at 50 Hz 690 V 3 AC				
• Rated current I_{rated} ¹⁾	A	14	19	23
• Base load current I_L ¹⁾	A	14	19	23
• Base load current I_H ²⁾	A	10	14	19
• I_{max}	A	20	28	38
Rated power				
• based on I_L	kW (hp)	11 (15)	15 (20)	18.5 (25)
• based on I_H	kW (hp)	7.5 (10)	11 (15)	15 (20)
Rated pulse frequency	kHz	16	16	16
Efficiency η		0.95	0.95	0.95
Power loss (at rated current)	kW	0.58	0.72	0.82
Cooling air requirement	m ³ /s	0.044	0.044	0.044
Sound pressure level L_{pA} (1 m)	dB	< 64	< 64	< 64
24 V DC power supply for Control Unit	A	1	1	1
Input current³⁾				
• Rated current	A	13	18	22
• based on I_H	A	10	13	18
Line supply connection U1/L1, V1/L2, W1/L3		Terminal strip	Terminal strip	Terminal strip
• Conductor cross-section	mm ²	2.5 ... 16	2.5 ... 16	2.5 ... 16
Motor connection U2, V2, W2		Terminal block	Terminal block	Terminal block
• Conductor cross-section	mm ²	2.5 ... 16	2.5 ... 16	2.5 ... 16
PE connection		On housing with M6 screw	On housing with M6 screw	On housing with M6 screw
Motor cable length, max.⁴⁾				
• Shielded	m	200	200	200
• Unshielded	m	300	300	300
Degree of protection		IP20	IP20	IP20
Dimensions				
• Width	mm	275	275	275
• Height	mm	512	512	512
• Depth				
- without Control Unit	mm	204	204	204
- with Control Unit	mm	260	260	260
Frame size		FSD	FSD	FSD
Weight, approx.				
• without integrated filter	kg	22	22	22
• with integrated filter	kg	23	23	23

¹⁾ The rated output current I_{rated} and the base load current I_L are based on the duty cycle for light overload (LO).

²⁾ The base load current I_H is based on the duty cycle for high overload (HO).

³⁾ The input current depends on the motor load and is valid for a line impedance corresponding to $u_K = 1\%$. The rated input currents apply for a load at the rated power (based on I_{rated}) – these current values are specified on the rating plate.

⁴⁾ Shielded motor cables must be used in order to maintain the limit values for field-conducted disturbances according to EN 61800-3 Class C2.

SINAMICS G120

Standard inverters 0.37 kW to 250 kW (0.5 hp to 400 hp)

PM260 Power Modules – 11 kW to 55 kW (15 hp to 75 hp)

Technical specifications

Line supply voltage 500 ... 690 V 3 AC		PM260 Power Modules		
Without integrated line filter		6SL3225-0BH32-2UA1	6SL3225-0BH33-0UA1	6SL3225-0BH33-7UA1
With integrated line filter		6SL3225-0BH32-2AA1	6SL3225-0BH33-0AA1	6SL3225-0BH33-7AA1
Output current at 50 Hz 690 V 3 AC				
• Rated current I_{rated} ¹⁾	A	35	42	62
• Base load current I_L ¹⁾	A	35	42	62
• Base load current I_H ²⁾	A	26	35	42
• I_{max}	A	52	70	84
Rated power				
• based on I_L	kW (hp)	30 (40)	37 (50)	55 (75)
• based on I_H	kW (hp)	22 (30)	30 (40)	37 (50)
Rated pulse frequency	kHz	16	16	16
Efficiency η		0.95	0.95	0.95
Power loss (at rated current)	kW	1.13	1.29	1.73
Cooling air requirement	m ³ /s	0.131	0.131	0.131
Sound pressure level L_{pA} (1 m)	dB	< 70	< 70	< 70
24 V DC power supply for Control Unit	A	1	1	1
Input current³⁾				
• Rated current	A	34	41	60
• based on I_H	A	26	34	41
Line supply connection				
U1/L1, V1/L2, W1/L3		M6 screw studs	M6 screw studs	M6 screw studs
• Conductor cross-section	mm ²	10 ... 50	10 ... 50	10 ... 50
Motor connection				
U2, V2, W2		M6 screw studs	M6 screw studs	M6 screw studs
• Conductor cross-section	mm ²	10 ... 50	10 ... 50	10 ... 50
PE connection				
		On housing with M6 screw	On housing with M6 screw	On housing with M6 screw
Motor cable length, max.⁴⁾				
• Shielded	m	200	200	200
• Unshielded	m	300	300	300
Degree of protection				
		IP20	IP20	IP20
Dimensions				
• Width	mm	350	350	350
• Height	mm	634	634	634
• Depth				
- without Control Unit	mm	316	316	316
- with Control Unit	mm	372	372	372
Frame size				
		FSF	FSF	FSF
Weight, approx.				
• without integrated filter	kg	56	56	56
• with integrated filter	kg	58	58	58

¹⁾ The rated output current I_{rated} and the base load current I_L are based on the duty cycle for light overload (LO).

²⁾ The base load current I_H is based on the duty cycle for high overload (HO).

³⁾ The input current depends on the motor load and is valid for a line impedance corresponding to $u_K = 1\%$. The rated input currents apply for a load at the rated power (based on I_{rated}) – these current values are specified on the rating plate.

⁴⁾ Shielded motor cables must be used in order to maintain the limit values for field-conducted disturbances according to EN 61800-3 Class C2.

Characteristic curves

Derating data

Ambient temperature

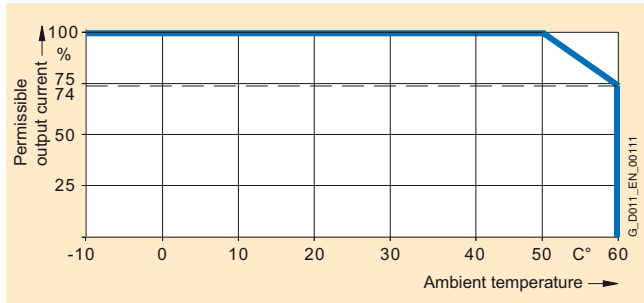

High overload (HO) PM260 frame size FSD

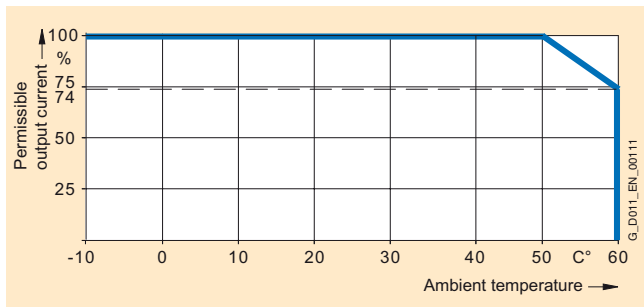

High overload (HO) PM260 frame size FSF

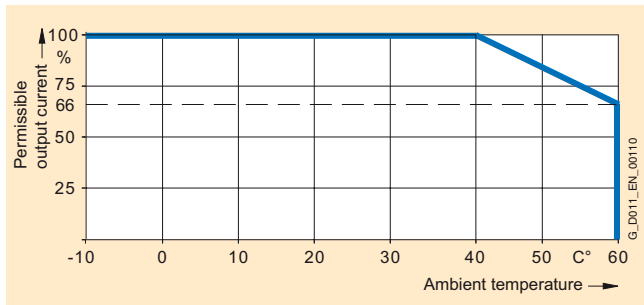

Light overload (LO) PM260 frame size FSD

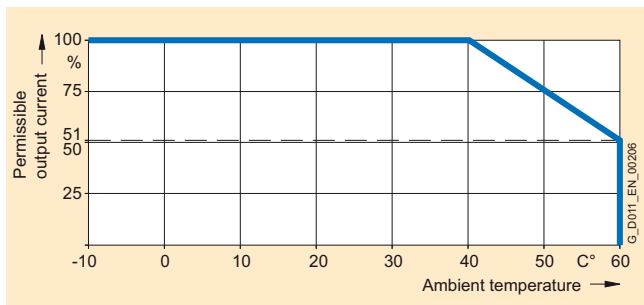

Light overload (LO) PM260 frame size FSF

Note: The operating temperature ranges of the Control Units should be taken into account. The temperature ranges are specified in the technical specifications under Control Units.

Installation altitude

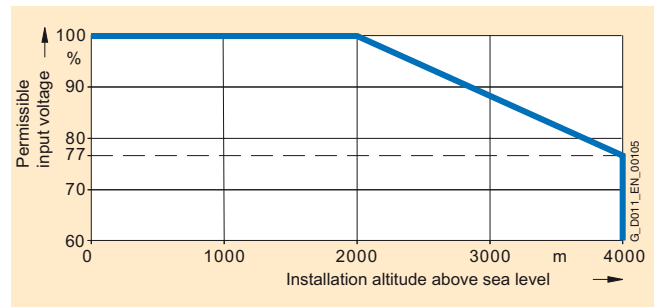
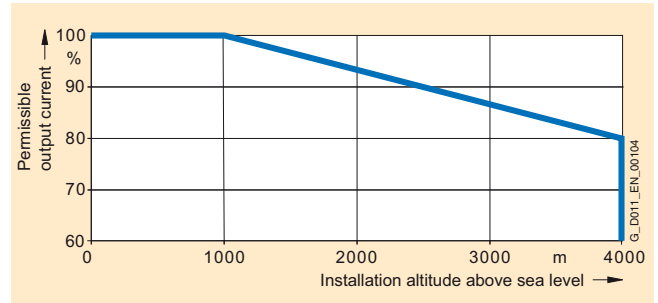

System operating voltage

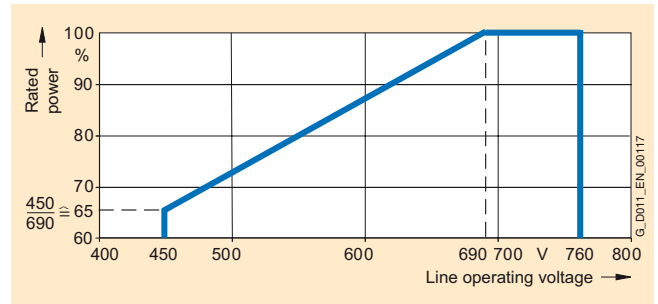

The power units can be operated with 500 V –10 %. In this case, the power is reduced linearly as required.

SINAMICS G120

Standard inverters 0.37 kW to 250 kW (0.5 hp to 400 hp)

PM260 Power Modules –
11 kW to 55 kW (15 hp to 75 hp)

Dimensional drawings

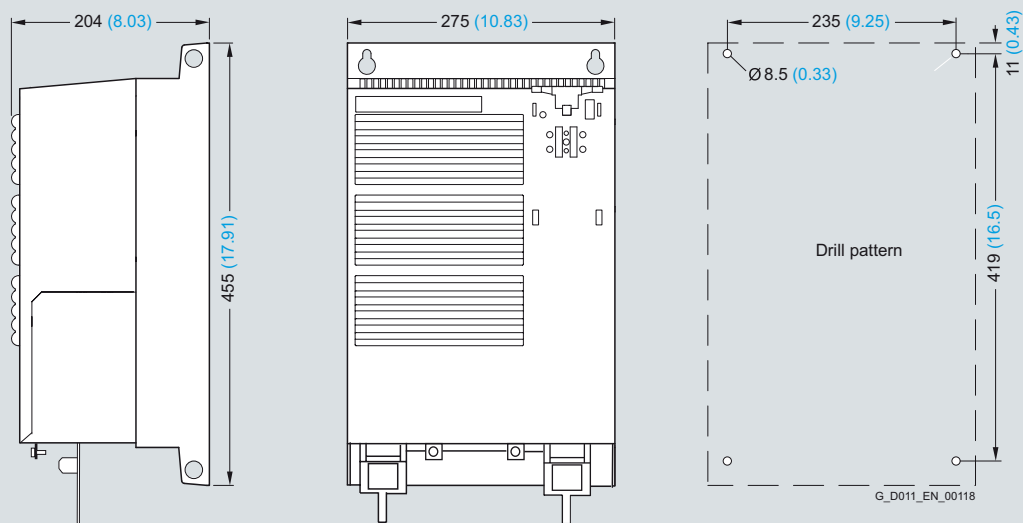

PM260 Power Module frame size FSD with and without integrated class A line filter

Mounted with 4 M6 studs, 4 M6 nuts, 4 M6 washers.

Ventilation clearance required at top and bottom: 300 mm (11.81 inches).

Ventilation clearance required at sides: 0 mm (0 inches).

When the Control Unit is plugged on, the mounting depth increases by 56 mm (2.2 inches).

Exception: for CU240E, mounting depth +22 mm (+0.87 inches).

All dimensions in mm (values in brackets are in inches).

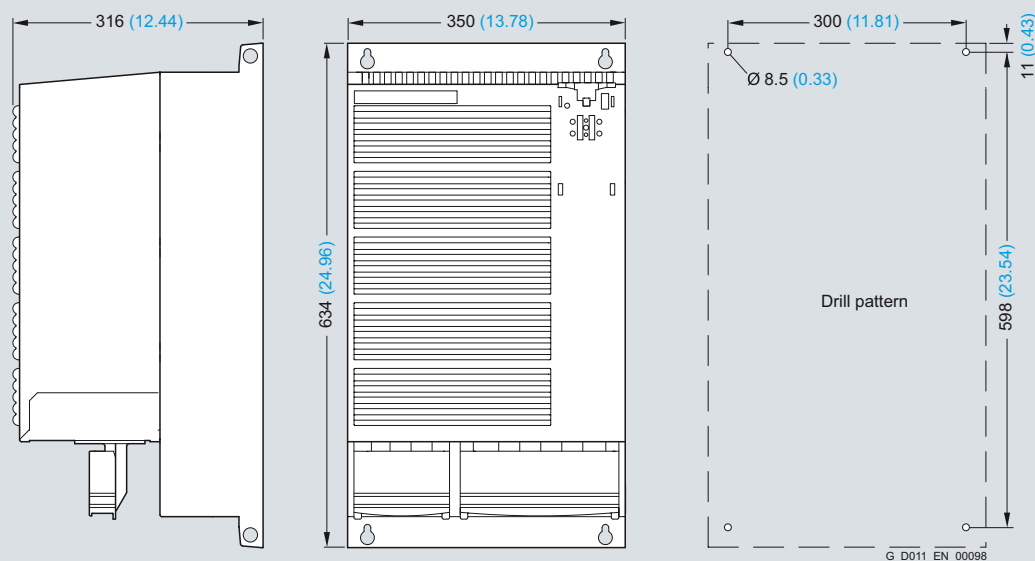

PM260 Power Module frame size FSF with and without integrated line filter class A

Mounted with 4 M8 studs, 4 M8 nuts, 4 M8 washers.

Ventilation clearance required at top and bottom: 350 mm (13.78 inches).

Ventilation clearance required at sides: 0 mm (0 inches).

When the Control Unit is plugged on, the mounting depth increases by 56 mm (2.2 inches).

Exception: for CU240E, mounting depth +22 mm (+0.87 inches).

All dimensions in mm (values in brackets are in inches).

SINAMICS G120

Standard inverters 0.37 kW to 250 kW (0.5 hp to 400 hp)

Compact inverters
0.37 kW to 15 kW (0.5 hp to 20 hp)

Overview



Example: Compact inverters, SINAMICS G120 with PM240 Power Module frame size FSB, CU240E Control Unit and BOP

The entry into SINAMICS G120 with an already assembled compact inverter

Three components can be ordered, completely assembled, with one Order No.: The PM240 Power Module with integrated brake choppers, the CU240E Control Unit and the BOP operator panel.

The compact inverter is suitable for applications in which the advantages of a compact inverter prevail (only one Order No., simpler to order). In this case, the advantages of a consistently modular system no longer apply (lower stockkeeping, high degree of flexibility).

The individual components of the compact inverter still remain completely modular. After they have been received, they can be separated at any time.

4

Selection and ordering data

Rated power ¹⁾		Power based on the base load current I_H ²⁾		Frame size and dimensions (H × W × D) mm	SINAMICS G120 compact inverter without integrated line filter Order No.	SINAMICS G120 compact inverter with integrated class A line filter Order No.
kW	hp	kW	hp			
47 ... 63 Hz 380 ... 480 V 3 AC ±10 %						
0.37	0.50	0.37	0.50	FSA 173 × 73 × 177	new 6SL3214-3AE13-7UB0	-
0.55	0.75	0.55	0.75		new 6SL3214-3AE15-5UB0	-
0.75	1.0	0.75	1.0		new 6SL3214-3AE17-5UB0	-
1.1	1.5	1.1	1.5		new 6SL3214-3AE21-1UB0	-
1.5	2.0	1.5	2.0		new 6SL3214-3AE21-5UB0	-
2.2	3.0	2.2	3.0	FSB 270 × 153 × 204	new 6SL3214-3AE22-2UB0	new 6SL3214-3AE22-2AB0
3.0	4.0	3.0	4.0		new 6SL3214-3AE23-0UB0	new 6SL3214-3AE23-0AB0
4.0	5.0	4.0	5.0		new 6SL3214-3AE24-0UB0	new 6SL3214-3AE24-0AB0
7.5	10	5.5	7.5	FSC 334 × 189 × 224	new 6SL3214-3AE25-5UB0	new 6SL3214-3AE25-5AB0
11.0	15	7.5	10		new 6SL3214-3AE27-5UB0	new 6SL3214-3AE27-5AB0
15.0	20	11.0	15		new 6SL3214-3AE31-1UB0	new 6SL3214-3AE31-1AB0

¹⁾ Rated power based on the rated output current I_{rated} . The rated output current I_{rated} is based on the duty cycle for light overload (LO). These current values are stamped on the rating plate of the Power Module.

²⁾ The base load current I_H is based on the duty cycle for high overload (HO).

SINAMICS G120

Standard inverters 0.37 kW to 250 kW (0.5 hp to 400 hp)

Line-side power components Line filters

Overview

With one of the additional line filters, the Power Module reaches a higher radio interference class.



Example: Line filter for Power Modules frame size FSA

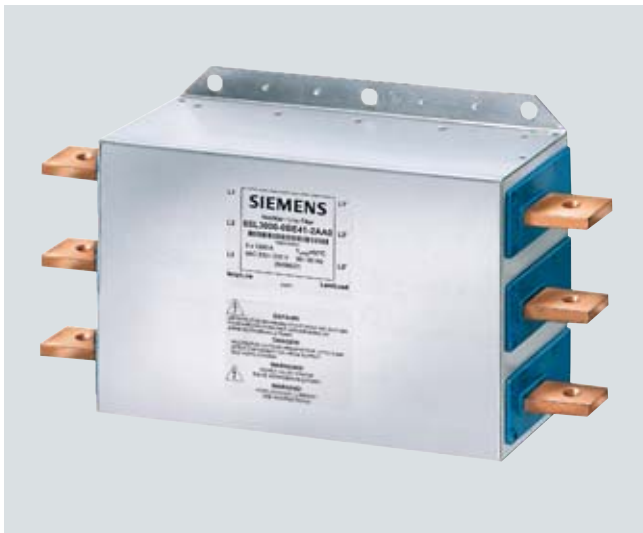

Example: Line filter for PM240 Power Modules frame size FSGX

Selection and ordering data

Rated power		SINAMICS G120 <u>PM240</u> Power Module		Class A line filter acc. to EN 55011	
kW	hp	Type 6SL3224-...	Frame size	Order No.	
380 ... 480 V 3 AC					
0.37	0.50	OBE13-7UA0	FSA	6SE6400-2FA00-6AD0	
0.55	0.75	OBE15-5UA0	FSA		
0.75	1.0	OBE17-5UA0	FSA		
1.1	1.5	OBE21-1UA0	FSA		
1.5	2.0	OBE21-5UA0	FSA	6SL3203-0BE32-5AA0	
110	150	OBE38-8UA0	FSF		
132	200	OBE41-1UA0	FSF	6SL3000-0BE34-4AA0	
160	250	OXE41-3UA0	FSGX <small>new</small>		
200	300	OXE41-6UA0	FSGX		
250	400	OXE42-0UA0	FSGX <small>new</small>	6SL3000-0BE36-0AA0	

Rated power		SINAMICS G120 <u>PM240</u> Power Module		Class B line filter acc. to EN 55011	
kW	hp	Type 6SL3224-...	Frame size	Order No.	
380 ... 480 V 3 AC					
0.37	0.50	OBE13-7UA0	FSA	6SE6400-2FB00-6AD0	
0.55	0.75	OBE15-5UA0	FSA		
0.75	1.0	OBE17-5UA0	FSA		
1.1	1.5	OBE21-1UA0	FSA		
1.5	2	OBE21-5UA0	FSA	6SL3203-0BE21-6SA0	
2.2	3	OBE22-2AA0	FSB		
3.0	4	OBE23-0AA0	FSB		
4.0	5	OBE24-0AA0	FSB	6SL3203-0BD23-8SA0	
7.5	10	OBE25-5AA0	FSC		
11	15	OBE27-5AA0	FSC		
15	20	OBE31-1AA0	FSC		

Rated power		SINAMICS G120 <u>PM250</u> Power Module		Class B line filter acc. to EN 55011	
kW	hp	Type 6SL3225-...	Frame size	Order No.	
380 ... 480 V 3 AC					
7.5	10	OBE25-5AA0	FSC	6SL3203-0BD23-8SA0	
11	15	OBE27-5AA0	FSC		
15	20	OBE31-1AA0	FSC		

SINAMICS G120

Standard inverters 0.37 kW to 250 kW (0.5 hp to 400 hp)

Line-side power components Line filters

Integration

Frame size FSA of the PM240 Power Module is available only without integrated class A line filter. A base filter is therefore available so that class A can be achieved. A class B base filter is also available so that class B can be achieved.

Frame sizes FSB and FSC of the PM240 Power Module are available both with and without integrated class A line filter. For compliance with class B, PM240 Power Modules with integrated class A line filter must be fitted additionally with a base filter to class B.

An external class A line filter is available for frame size FSGX of the PM240 Power Module.

Frame sizes FSD of the PM250 Power Module are available only with integrated class A line filter. For compliance with class B, PM250 Power Modules must be fitted additionally with a class B base filter.

No additional Class B line filters are available for the PM260 Power Module.

Line filters which are optionally available depending on the Power Module used

	Frame size						
	FSA	FSB	FSC	FSD	FSE	FSF	FSGX
PM240 Power Module with integrated brake chopper							without integrated brake chopper
Available frame sizes	✓	✓	✓	✓	✓	✓	✓
Line-side power components							
Line filter, class A	U	F	F	F	F	F/S ¹⁾	S ¹⁾
Line filter, class B	U	U	U	–	–	–	–
PM250 Power Module with line-commutated energy recovery							
Available frame sizes	–	–	✓	✓	✓	✓	–
Line-side power components							
Line filter, class A	–	–	I	F	F	F	–
Line filter, class B	–	–	U	–	–	–	–
PM260 Power Module with line-commutated energy recovery and integrated sine-wave filter							
Available frame sizes	–	–	–	✓	–	✓	–
Line-side power components							
Line filter, class A	–	–	–	F	–	F	–
Line filter, class B	–	–	–	–	–	–	–

U = Base component

S = Lateral mounting

I = Integrated

– = Not possible

F = Power Modules available with and without integrated class A filter

¹⁾ PM240 FSF Power Modules, from 110 kW (150 hp) and higher and FSGX are available only without an integrated class A filter. An optional class A line filter for side mounting is available instead.

SINAMICS G120

Standard inverters 0.37 kW to 250 kW (0.5 hp to 400 hp)

Line-side power components Line filters

Technical specifications

Line supply voltage 380 ... 480 V 3 AC		Line filter class A			
		6SE6400-2FA00-6AD0	6SL3203-0BE32-5AA0	6SL3000-0BE34-4AA0	6SL3000-0BE36-0AA0
Rated current	A	6	250	440	600
Line supply connection L1, L2, L3		Screw terminals	On housing with M8 screw studs	1 × hole for M10 Provided for busbar connection	1 × hole for M10 Provided for busbar connection
• Conductor cross-section	mm ²	2.5	–	–	–
Load connection U, V, W		Shielded cable	On housing with M8 screw studs	On housing with M10 screw studs	On housing with M10 screw studs
• Conductor cross-section	mm ²	3 × 2.5	–	–	–
• Length	m	0.4	–	–	–
PE connection		On housing with M4 screw studs	Flat connector for M10 screw	1 × hole for M8	1 × hole for M10
Degree of protection		IP20	IP00	IP00	IP00
Dimensions					
• Width	mm	73	240	360	400
• Height	mm	200	360	240	265
• Depth	mm	42.5	116	116	140
Possible as base component		yes	no	no	no
Weight, approx.	kg	0.5	12.4	12.3	19
Suitable for PM240 Power Module	Type	6SL3224-0BE13-7UA0 6SL3224-0BE15-5UA0 6SL3224-0BE17-5UA0 6SL3224-0BE21-1UA0 6SL3224-0BE21-5UA0	6SL3224-0BE38-8UA0 6SL3224-0BE41-1UA0	6SL3224-0XE41-3UA0 6SL3224-0XE41-6UA0	6SL3224-0XE42-0UA0
Suitable for PM250 Power Module		–	–	–	–
Frame size		FSA	FSF	FSGX	FSGX

Line supply voltage 380 ... 480 V 3 AC		Line filter class B		
		6SE6400-2FB00-6AD0	6SL3203-0BE21-6SA0	6SL3203-0BD23-8SA0
Rated current	A	6	10.2	39.4
Line supply connection L1, L2, L3		Screw terminals	Screw terminals	Screw terminals
• Conductor cross-section	mm ²	2.5	2.5	4
Load connection U, V, W		Shielded cable	Shielded cable	Shielded cable
• Conductor cross-section	mm ²	3 × 2.5	3 × 2.5	3 × 4
• Length	m	0.4	0.4	0.4
PE connection		On housing with M4 screw studs	On housing with M4 screw studs	On housing with M4 screw studs
Degree of protection		IP20	IP20	IP20
Dimensions				
• Width	mm	73	153	190
• Height	mm	200	296	362
• Depth	mm	42.5	50	55
Possible as base component		yes	yes	yes
Weight, approx.	kg	0.5	1.5	2.3
Suitable for PM240 Power Module	Type	6SL3224-0BE13-7UA0 6SL3224-0BE15-5UA0 6SL3224-0BE17-5UA0 6SL3224-0BE21-1UA0 6SL3224-0BE21-5UA0	6SL3224-0BE22-2AA0 6SL3224-0BE23-0AA0 6SL3224-0BE24-0AA0	6SL3224-0BE25-5AA0 6SL3224-0BE27-5AA0 6SL3224-0BE31-1AA0
Suitable for PM250 Power Module		–	–	6SL3225-0BE25-5AA0 6SL3225-0BE27-5AA0 6SL3225-0BE31-1AA0
Frame size		FSA	FSB	FSC

Overview

A line reactor reduces the system perturbations caused by harmonics. This particularly applies in the case of weak line supplies (line supply short-circuit power $u_K > 1\%$).



Example: Line reactors for Power Modules frame sizes FSA to FSE



Example: Line reactor for PM240 Power Modules frame size FSGX



Example: Power Module frame size FSB with base line reactor and shield bonding plate

Note: A line reactor must not be used in combination with a PM250 or PM260 Power Module.

Benefits

Only AC reactors are available as reactors for the inverter.

- Only an AC reactor provides protection for the input rectifier of the inverter.
- The capacitor lifetime of the inverter increases when using an AC reactor by a factor of 2 when compared to the lifetime when using a DC reactor.
- The harmonic behavior of AC reactors remain almost constant over the complete lifetime. Over time (months), the harmonic behavior of DC reactors changes.
- An AC reactor reduces possible dissymmetries between the current phases. In this case, a DC reactor would not be effective.

SINAMICS G120

Standard inverters 0.37 kW to 250 kW (0.5 hp to 400 hp)

Line-side power components Line reactors

Selection and ordering data

Rated power		SINAMICS G120 PM240 Power Module		Line reactor
kW	hp	Type 6SL3224-...	Frame size	Order No.
380 ... 480 V 3 AC				
0.37	0.50	0BE13-7UA0	FSA	6SE6400-3CC00-2AD3
0.55	0.75	0BE15-5UA0	FSA	
0.75	1.0	0BE17-5UA0	FSA	6SE6400-3CC00-4AD3
1.1	1.5	0BE21-1UA0	FSA	
1.5	2	0BE21-5UA0	FSA	6SE6400-3CC00-6AD3
2.2	3	0BE22-2 . A0	FSB	6SL3203-0CD21-0AA0
3.0	4	0BE23-0 . A0	FSB	
4.0	5	0BE24-0 . A0	FSB	6SL3203-0CD21-4AA0
7.5	10	0BE25-5 . A0	FSC	6SL3203-0CD22-2AA0
11.0	15	0BE27-5 . A0	FSC	
15.0	20	0BE31-1 . A0	FSC	6SL3203-0CD23-5AA0
18.5	25	0BE31-5 . A0	FSD	6SL3203-0CJ24-5AA0
22	30	0BE31-8 . A0	FSD	
30	40	0BE32-2 . A0	FSD	6SL3203-0CD25-3AA0
37	50	0BE33-0 . A0	FSE	6SL3203-0CJ28-6AA0
45	60	0BE33-7 . A0	FSE	
55	75	0BE34-5 . A0	FSF	6SE6400-3CC11-2FD0
75	100	0BE35-5 . A0	FSF	
90	125	0BE37-5 . A0	FSF	6SE6400-3CC11-7FD0
110	150	0BE38-8UA0	FSF	6SL3000-0CE32-3AA0
132	200	0BE41-1UA0	FSF	6SL3000-0CE32-8AA0
160	250	0XE41-3UA0	FSGX	new 6SL3000-0CE33-3AA0
200	300	0XE41-6UA0	FSGX	new 6SL3000-0CE35-1AA0
250	400	0XE42-0UA0	FSGX	

Integration

The line reactors for PM240 Power Modules, frame sizes FSA to FSE, are designed as base components. The line reactor is attached to the mounting surface and the Power Module is mounted directly on the line reactor in a space-saving fashion.

The cables to the Power Module are already connected at the line reactor.

The line reactor is connected to the line supply through terminals.

Line reactors which are optionally available depending on the Power Module used

	Frame size							
	FSA	FSB	FSC	FSD	FSE	FSF	FSGX	
PM240 Power Module with integrated brake chopper								without integrated brake chopper
Available frame sizes	✓	✓	✓	✓	✓	✓	✓	✓
Line-side power components								
Line reactor	U	U	U	U	U	S	S	
PM250 Power Module with line-commutated energy recovery								
Available frame sizes	–	–	✓	✓	✓	✓	–	–
Line-side power components								
Line reactor ¹⁾	–	–	– ¹⁾	– ¹⁾	– ¹⁾	– ¹⁾	–	–
PM260 Power Module with line-commutated energy recovery and integrated sine-wave filter								
Available frame sizes	–	–	–	✓	–	✓	–	–
Line-side power components								
Line reactor ¹⁾	–	–	–	– ¹⁾	–	– ¹⁾	–	–

U = Base component

S = Lateral mounting

– = Not possible

¹⁾ A line reactor is not required and must not be used in conjunction with a PM250 or PM260 Power Module.

SINAMICS G120

Standard inverters 0.37 kW to 250 kW (0.5 hp to 400 hp)

Line-side power components
Line reactors

Technical specifications

Line supply voltage 380 ... 480 V 3 AC		Line reactor			
		6SE6400-3CC00-2AD3	6SE6400-3CC00-4AD3	6SE6400-3CC00-6AD3	6SL3203-0CD21-0AA0
Rated current	A	1.9	3.5	4.8	9
Power loss at 50/60 Hz, approx.	W	6/7	12.5/15	7.5/9	9/11
Line supply connection U1, V1, W1		Screw terminals	Screw terminals	Screw terminals	Screw terminals
• Conductor cross-section	mm ²	6	6	6	6
Load connection		Cable	Cable	Cable	Cable
• Conductor cross-section		4 × AWG16 (1.5 mm ²)	4 × AWG16 (1.5 mm ²)	4 × AWG16 (1.5 mm ²)	4 × AWG16 (1.5 mm ²)
• Length, approx.	m	0.38	0.38	0.38	0.46
PE connection		On housing with M5 screw studs	On housing with M5 screw studs	On housing with M5 screw studs	On housing with M5 screw studs
Degree of protection		IP20	IP20	IP20	IP20
Dimensions					
• Width	mm	75.5	75.5	75.5	153
• Height	mm	200	200	200	290
• Depth	mm	50	50	50	50
Possible as base component		yes	yes	yes	yes
Weight, approx.	kg	0.6	0.8	0.6	3.4
Suitable for PM240 Power Module	Type	6SL3224-0BE13-7UA0 6SL3224-0BE15-5UA0	6SL3224-0BE17-5UA0 6SL3224-0BE21-1UA0	6SL3224-0BE21-5UA0	6SL3224-0BE22-2 . A0 6SL3224-0BE23-0 . A0
Frame size		FSA	FSA	FSA	FSB

Line supply voltage 380 ... 480 V 3 AC		Line reactor			
		6SL3203-0CD21-4AA0	6SL3203-0CD22-2AA0	6SL3203-0CD23-5AA0	6SL3203-0CJ24-5AA0
Rated current	A	11.6	25	31.3	47
Power loss at 50/60 Hz, approx.	W	27/32	98/118	37/44	90/115
Line supply connection U1, V1, W1		Screw terminals	Screw terminals	Screw terminals	Screw terminals
• Conductor cross-section	mm ²	6	6	16	16
Load connection		Cable	Cable	Cable	Cable
• Conductor cross-section		4 × AWG16 (1.5 mm ²)	4 × AWG10 (2.5 mm ²)	4 × AWG10 (2.5 mm ²)	4 × 16 mm ²
• Length, approx.	m	0.46	0.49	0.49	0.7
PE connection		On housing with M5 screw studs	On housing with M5 screw studs	On housing with M5 screw studs	On housing with M8 screw
Degree of protection		IP20	IP20	IP20	IP20
Dimensions					
• Width	mm	153	189	189	275
• Height	mm	290	371	371	455
• Depth	mm	50	50	50	84
Possible as base component		yes	yes	yes	yes
Weight, approx.	kg	3.4	5.2	5.9	13
Suitable for PM240 Power Module	Type	6SL3224-0BE24-0 . A0	6SL3224-0BE25-5 . A0 6SL3224-0BE27-5 . A0	6SL3224-0BE31-1 . A0	6SL3224-0BE31-5 . A0 6SL3224-0BE31-8 . A0
Frame size		FSB	FSC	FSC	FSD

SINAMICS G120

Standard inverters 0.37 kW to 250 kW (0.5 hp to 400 hp)

Line-side power components Line reactors

Technical specifications

Line supply voltage 380 ... 480 V 3 AC		Line reactor					
		6SL3203-0CD25-3AA0	6SL3203-0CJ28-6AA0	6SE6400-3CC11-2FD0	6SE6400-3CC11-7FD0	6SL3000-0CE32-3AA0	6SL3000-0CE32-8AA0
Rated current	A	63	94	151	186	224	278
Power loss at 50/60 Hz, approx.	W	90/115	170/215	280/360	280/360	240/270	210/250
Line supply connection U1, V1, W1		Screw terminals	Screw terminals	Flat connector for M10 cable lug	Flat connector for M10 cable lug	Flat connector for M10 screw	Flat connector for M10 screw
• Conductor cross-section	mm ²	16	50	–	–	–	–
Load connection		Cable	Cable	Flat connector for M10 cable lug	Flat connector for M10 cable lug	Flat connector for M10 screw	Flat connector for M10 screw
• Conductor cross-section	mm ²	4 x 16	4 x 35	–	–	–	–
• Length, approx.	m	0.7	0.7	–	–	–	–
PE connection		On housing with M8 screw	On housing with M8 screw	On housing with M8 screw stud	On housing with M8 screw stud	M6 screw	M6 screw
Degree of protection		IP20	IP20	IP00	IP00	IP00	IP00
Dimensions							
• Width	mm	275	275	240	240	270	270
• Height	mm	455	577	228	228	248	248
• Depth	mm	84	94	141	141	200	200
Possible as base component		yes	yes	no	no	no	no
Weight, approx.	kg	13	19	25	25	24	24
Suitable for PM240 Power Module	Type	6SL3224-0BE32-2 . A0	6SL3224-0BE33-0 . A0 6SL3224-0BE33-7 . A0	6SL3224-0BE34-5 . A0 6SL3224-0BE35-5 . A0	6SL3224-0BE37-5 . A0	6SL3224-0BE38-8UA0	6SL3224-0BE41-1UA0
Frame size		FSD	FSE	FSF	FSF	FSF	FSF

Line supply voltage 380 ... 480 V 3 AC		Line reactor	
		6SL3000-0CE33-3AA0	6SL3000-0CE33-5AA0
Rated current	A	331	508
Power loss at 50/60 Hz, approx.	W	0.267	0.365
Line supply connection U1, V1, W1		1 x hole for M10	1 x hole for M12
• Conductor cross-section	mm ²	provided for busbar connection	provided for busbar connection
Load connection			
• Conductor cross-section	mm ²	provided for busbar connection	provided for busbar connection
PE connection		M6 screw	M6 screw
Degree of protection		IP00	IP00
Dimensions			
• Width	mm	270	300
• Height	mm	248	269
• Depth	mm	200	212
Possible as base component		no	no
Weight, approx.	kg	27.8	38.0
Suitable for PM240 Power Module	Type	6SL3224-0XE41-3UA0	6SL3224-0XE41-6UA0 6SL3224-0XE42-0UA0
Frame size		FSGX	FSGX

Standard inverters 0.37 kW to 250 kW (0.5 hp to 400 hp)

Line-side power components
Recommended line components

Overview

The following table lists recommendations for additional line-side components, such as fuses and circuit breakers (line-side components dimensioned in accordance with IEC standards). The specified circuit breakers are UL-certified.

3NA3 fuses are recommended for European countries. The 3NE1 fuses are UL-compliant (corresponds to RU). The values in the table take into account the overload capability of the inverter.

Additional information about the listed fuses and circuit breakers can be found in Catalogs LV 1 and LV 1 T.

Selection and ordering data

Rated power		SINAMICS G120 PM240 Power Modules		Fuse		Circuit breaker	
kW	hp	Type 6SL3224-...	Frame size	Type 3NA3 Order No.	Type 3NE1 (RU) Order No.	Order No.	
380 ... 480 V 3 AC							
0.37	0.50	OBE13-7UA0	FSA	3NA3803	UL-listed fuses such as the Class NON fuse series from Bussmann are required for North America.	3RV1021-1CA10	
0.55	0.75	OBE15-5UA0	FSA			3RV1021-1DA10	
0.75	1.0	OBE17-5UA0	FSA			3RV1021-1FA10	
1.1	1.5	OBE21-1UA0	FSA			3RV1021-1GA10	
1.5	2	OBE21-5UA0	FSA			3RV1021-1JA10	
2.2	3	OBE22-2 . A0	FSB			3NA3805	3RV1021-1KA10
3.0	4	OBE23-0 . A0	FSB			3NA3807	3RV1021-4AA10
4.0	5	OBE24-0 . A0	FSB			3NA3807	3RV1021-4BA10
7.5	10	OBE25-5 . A0	FSC			3NA3812	3RV1031-4EA10
11.0	15	OBE27-5 . A0	FSC			3NA3812	3RV1031-4FA10
15.0	20	OBE31-1 . A0	FSC	3NA3814	3RV1031-4HA10		
18.5	25	OBE31-5 . A0	FSD	3NA3820	3NE1817-0	3RV1042-4KA10	
22	30	OBE31-8 . A0	FSD	3NA3822	3NE1818-0		
30	40	OBE32-2 . A0	FSD	3NA3824	3NE1820-0	3RV1042-4MA10	
37	50	OBE33-0 . A0	FSE	3NA3830	3NE1021-0	3VL1712-.DD33-....	
45	60	OBE33-7 . A0	FSE	3NA3832	3NE1022-0	3VL1716-.DD33-....	
55	75	OBE34-5 . A0	FSF	3NA3836	3NE1224-0	3VL3720-.DC36-....	
75	100	OBE35-5 . A0	FSF	3NA3140	3NE1225-0	3VL3725-.DC36-....	
90	125	OBE37-5 . A0	FSF	3NA3144	3NE1227-0	3VL4731-.DC36-....	
110	150	OBE38-8UA0	FSF	–			
132	200	OBE41-1UA0	FSF	–	3NE1230-0		
160	250	0XE41-3UA0	FSGX	new 3NA3254	new 3NE1333-2	new 3VL4740-.DC36-....	
200	300	OBE41-6UA0	FSGX	new 3NA3260		new 3VL5750-.DC36-....	
250	400	OBE42-0UA0	FSGX	new 3NA3372	new 3NE1436-2		

SINAMICS G120

Standard inverters 0.37 kW to 250 kW (0.5 hp to 400 hp)

Line-side power components Recommended line components

Selection and ordering data

Rated power		SINAMICS G120 <u>PM250</u> Power Modules		Fuse		Circuit breaker
kW	hp	Type 6SL3225-...	Frame size	Type 3NA3 Order No.	Type 3NE1 (RU) Order No.	Order No.
380 ... 480 V 3 AC						
7.5	10	OBE25-5AA0	FSC	3NA3807	UL-listed fuses such as the Class NON fuse series from Bussmann are required for North America.	3RV1031-4EA10
11.0	15	OBE27-5AA0	FSC	3NA3812		3RV1031-4FA10
15.0	20	OBE31-1AA0	FSC	3NA3814		3RV1031-4HA10
18.5	25	OBE31-5 . A0	FSD	3NA3820	3NE1817-0	3RV1042-4KA10
22	30	OBE31-8 . A0	FSD	3NA3822	3NE1818-0	
30	40	OBE32-2 . A0	FSD	3NA3824	3NE1820-0	3RV1042-4MA10
37	50	OBE33-0 . A0	FSE	3NA3830	3NE1021-0	3VL1712-.DD33-....
45	60	OBE33-7 . A0	FSE	3NA3832	3NE1022-0	3VL1716-.DD33-....
55	75	OBE34-5 . A0	FSF	3NA3836	3NE1224-0	3VL3720-.DC36-....
75	100	OBE35-5 . A0	FSF	3NA3140	3NE1225-0	3VL3725-.DC36-....
90	125	OBE37-5 . A0	FSF	3NA3144	3NE1227-0	3VL4731-.DC36-....

Rated power		SINAMICS G120 <u>PM260</u> Power Modules		Fuse		Circuit breaker
kW	hp	Type 6SL3225-...	Frame size	Type 3NA3 Order No.	Type 3NE1 (RU) Order No.	Order No.
500 ... 690 V 3 AC						
11.0	15	OBH27-5 . A1	FSD	3NA3120-6	–	3RV1041-4FA10
15.0	20	OBH31-1 . A1	FSD			
18.5	25	OBH31-5 . A1	FSD			
30	40	OBH32-2 . A1	FSF	3NA3122-6		3RV1041-4JA10
37	50	OBH33-0 . A1	FSE			3RV1041-4KA10
55	75	OBH33-7 . A1	FSF	3NA3130-6		3RV1041-4MA10

4

Standard inverters 0.37 kW to 250 kW (0.5 hp to 400 hp)

DC link components
Braking resistors

Overview



Example: Braking resistors for Power Modules, frame sizes FSA and FSC



Example: Braking resistor for PM240 Power Modules frame size FSGX

Excess energy in the DC link is dissipated in the braking resistor. The braking resistors are intended for use with PM240 Power Modules which feature an integrated brake chopper, but cannot regenerate energy to the supply system. There is an optional plug-in Braking Module for frame size FSGX. For generator operation, e.g. the braking of a rotating mass with high moment of inertia, a braking resistor must be connected to convert the resulting energy into heat.

The braking resistors can be installed at the side of the PM240 Power Modules. The braking resistors for the FSA and FSB frame sizes are designed as base components. If the PM240 Power Modules, frame size FSA or FSB, are operated without line reactor, the braking resistors can also be installed under the Power Modules.

The braking resistors for the Power Modules, frame sizes FSC to FSGX, should be placed outside the control cabinet or outside the switchgear room so that the heat is dissipated away from the Power Modules. The level of air conditioning required is therefore reduced.

Every braking resistor has a temperature switch (UL-listed). The temperature switch can be evaluated to prevent consequential damage if the braking resistor overheats.

Selection and ordering data

Rated power		SINAMICS G120 PM240 Power Module		Braking resistor
kW	hp	Type 6SL3224-...	Frame size	Order No.
380 ... 480 V 3 AC				
0.37	0.50	OBE13-7UA0	FSA	6SE6400-4BD11-0AA0
0.55	0.75	OBE15-5UA0	FSA	
0.75	1.0	OBE17-5UA0	FSA	
1.1	1.5	OBE21-1UA0	FSA	
1.5	2	OBE21-5UA0	FSA	6SL3201-0BE12-0AA0
2.2	3	OBE22-2 . A0	FSB	
3.0	4	OBE23-0 . A0	FSB	
4.0	5	OBE24-0 . A0	FSB	6SE6400-4BD16-5CA0
7.5	10	OBE25-5 . A0	FSC	
11.0	15	OBE27-5 . A0	FSC	
15.0	20	OBE31-1 . A0	FSC	
18.5	25	OBE31-5 . A0	FSD	6SE6400-4BD21-2DA0
22	30	OBE31-8 . A0	FSD	
30	40	OBE32-2 . A0	FSD	6SE6400-4BD22-2EA1
37	50	OBE33-0 . A0	FSE new	
45	60	OBE33-7 . A0	FSE	6SE6400-4BD24-0FA0
55	75	OBE34-5 . A0	FSF	
75	100	OBE35-5 . A0	FSF	
90	125	OBE37-5 . A0	FSF	6SE6400-4BD26-0FA0
110	150	OBE38-8UA0	FSF	
132	200	OBE41-1UA0	FSF	6SL3000-1BE31-3AA0
160	250	OXE41-3UA0	FSGX ¹⁾ new	
200	300	OXE41-6UA0	FSGX ¹⁾ new	6SL3000-1BE32-5AA0
250	400	OXE42-0UA0	FSGX ¹⁾	

¹⁾ A Braking Module must be additionally ordered for connection.

SINAMICS G120

Standard inverters 0.37 kW to 250 kW (0.5 hp to 400 hp)

DC link components Braking resistors

Integration

Braking resistors which are optionally available depending on the Power Module used

	Frame size						
	FSA	FSB	FSC	FSD	FSE	FSF	FSGX
PM240 Power Module with integrated brake chopper							
							without integrated brake chopper
Available frame sizes	✓	✓	✓	✓	✓	✓	✓
DC link components							
Braking resistor	U	U	S	S	S	S	S
PM250 Power Module with line-commutated energy recovery							
Available frame sizes	–	–	✓	✓	✓	✓	–
DC link components							
Braking resistor ¹⁾	–	–	– ¹⁾	– ¹⁾	– ¹⁾	– ¹⁾	–
PM260 Power Module with line-commutated energy recovery and integrated sine-wave filter							
Available frame sizes	–	–	–	✓	–	✓	–
DC link components							
Braking resistor ¹⁾	–	–	–	– ¹⁾	–	– ¹⁾	–

U = Base component

S = Lateral mounting

– = Not possible

Technical specifications

Line supply voltage 380 V ... 480 V 3 AC	Braking resistor			
		6SE6400-4BD11-0AA0	6SL3201-0BE12-0AA0	6SE6400-4BD16-5CA0
Resistor	Ω	390	160	56
Rated power P_{DB}	kW (hp)	0.1 (0.13)	0.2 (0.27)	0.65 (0.87)
Peak power P_{max} (cycle time 12 s)	kW	2	4	11
Power connections		Shielded cable	Shielded cable	Shielded cable
• Conductor cross-section	mm ²	3 × 2.5	3 × 2.5	3 × 2.5
• Length	m	0.5	0.5	0.9
Thermostatic switch (NC contact) Max. contact load		250 V AC/2.5 A	250 V AC/2.5 A	250 V AC/2.5 A
Degree of protection		IP20	IP20	IP20
Frame size		FSA	FSB	FSC
Dimensions				
• Width	mm	72	153	185
• Height	mm	230	329	285
• Depth	mm	43.5	43.5	150
Possible as base component		yes	yes	no
Weight, approx.	kg	1	2	3.8
Suitable for PM240 Power Module	Type	6SL3224-0BE13-7UA0 6SL3224-0BE15-5UA0 6SL3224-0BE17-5UA0 6SL3224-0BE21-1UA0 6SL3224-0BE21-5UA0	6SL3224-0BE22-2.A0 6SL3224-0BE23-0.A0 6SL3224-0BE24-0.A0	6SL3224-0BE25-5.A0 6SL3224-0BE27-5.A0 6SL3224-0BE31-1.A0
Frame size		FSA	FSB	FSC

¹⁾ Line-commutated energy recovery is possible in conjunction with a PM250 or PM260 Power Module. A braking resistor cannot be connected and is not necessary.

SINAMICS G120

Standard inverters 0.37 kW to 250 kW (0.5 hp to 400 hp)

DC link components
Braking resistors

Technical specifications

Line supply voltage 380 V ... 480 V 3 AC		Braking resistor			
		6SE6400-4BD21-2DA0	6SE6400-4BD22-2EA1	6SE6400-4BD24-0FA0	6SE6400-4BD26-0FA0
Resistor	Ω	27	15	8.2	5.5
Rated power P_{DB}	kW (hp)	1.2 (1.6)	2.2 (3.0)	4 (5)	5.6 (7.5)
Peak power P_{max} (cycle time 12 s)	kW	24	44	80	120
Power connections		M6 screw studs	M6 screw studs	M6 screw studs	M6 screw studs
Thermostatic switch (NC contact) Max. contact load		250 V AC/2.5 A	250 V AC/2.5 A	250 V AC/2.5 A	250 V AC/2.5 A
Degree of protection		IP20	IP20	IP20	IP20
Frame size		FSD	FSE	FSF	FSF
Dimensions					
• Width	mm	270	326	395	526
• Height	mm	515	301	650	301
• Depth	mm	175	484	315	484
Possible as base component		no	no	no	no
Weight, approx.	kg	7.4	11	16.7	17.5
Suitable for PM240 Power Module	Type	6SL3224-0BE31-5.A0 6SL3224-0BE31-8.A0 6SL3224-0BE32-2.A0	6SL3224-0BE33-0.A0 6SL3224-0BE33-7.A0	6SL3224-0BE34-5.A0 6SL3224-0BE35-5.A0 6SL3224-0BE37-5.A0	6SL3224-0BE38-8UA0 6SL3224-0BE41-1UA0
Frame size		FSD	FSE	FSF	FSF

Line supply voltage 380 V ... 480 V 3 AC		Braking resistor	
		6SL3000-1BE31-3AA0	6SL3000-1BE32-5AA0
Resistor	Ω	4.4	2.2
Rated power P_{DB}	kW (hp)	25 (34)	50 (67)
Peak power P_{max} (cycle time 15 s every 90 s)	kW	125	250
Power connections		M10 screw stud	M10 screw stud
Thermostatic switch (NC contact) Max. contact load		250 V AC/2.5 A	250 V AC/2.5 A
Degree of protection		IP20	IP20
Frame size		FSGX	FSGX
Dimensions			
• Width	mm	740	810
• Height	mm	605	1325
• Depth	mm	485	485
Possible as base component		no	no
Weight, approx.	kg	50	120
Suitable for PM240 Power Module	Type	6SL3224-0XE41-3UA0	6SL3224-0XE41-6UA0 6SL3224-0XE42-0UA0
Frame size		FSGX	FSGX

SINAMICS G120

Standard inverters 0.37 kW to 250 kW (0.5 hp to 400 hp)

DC link components Braking Modules

Overview

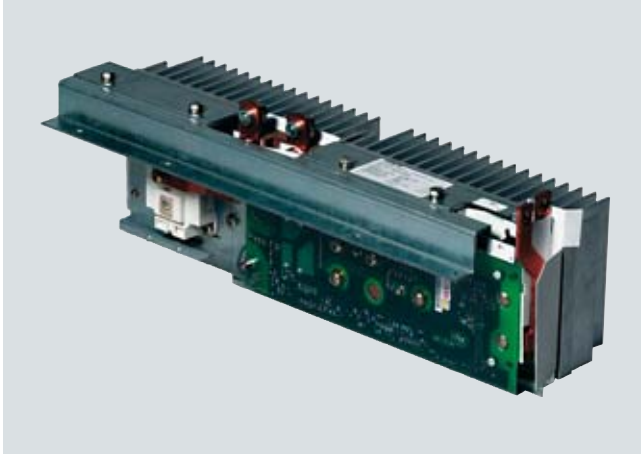

A Braking Module and the matching external braking resistor are required to bring drives to a controlled standstill in the event of a power failure (e.g. emergency retraction or EMERGENCY STOP Category 1) or limit the DC link voltage for brief periods of generator operation. The Braking Module includes the power electronics and the associated control circuit. During operation, the DC link energy is converted to heat loss in an external braking resistor. Braking Modules function autonomously.

The Braking Module is designed for installation in PM240 Power Modules, frame size FSGX and is cooled by the Power Module fan. The supply voltage for the electronics is taken from the DC link. The Braking Module is connected to the DC link using the busbar sets included in the scope of delivery.

The activation threshold of the Braking Module can be adjusted by means of a DIP switch. The braking power values specified in the technical specifications apply to the upper activation threshold.

Selection and ordering data

Description	Order No.
DC link voltage 510 ... 720 V DC	
Braking Module 50 kW/250 kW	new 6SL3300-1AE32-5AA0

Design

The Braking Module has the following interfaces as standard:

- 1 DC link connection
- 1 braking resistor connection
- 1 digital input (inhibit Braking Module/acknowledge fault)
- 1 digital output (Braking Module inhibited)
- 1 DIP switch for adjusting the activation threshold

Integration

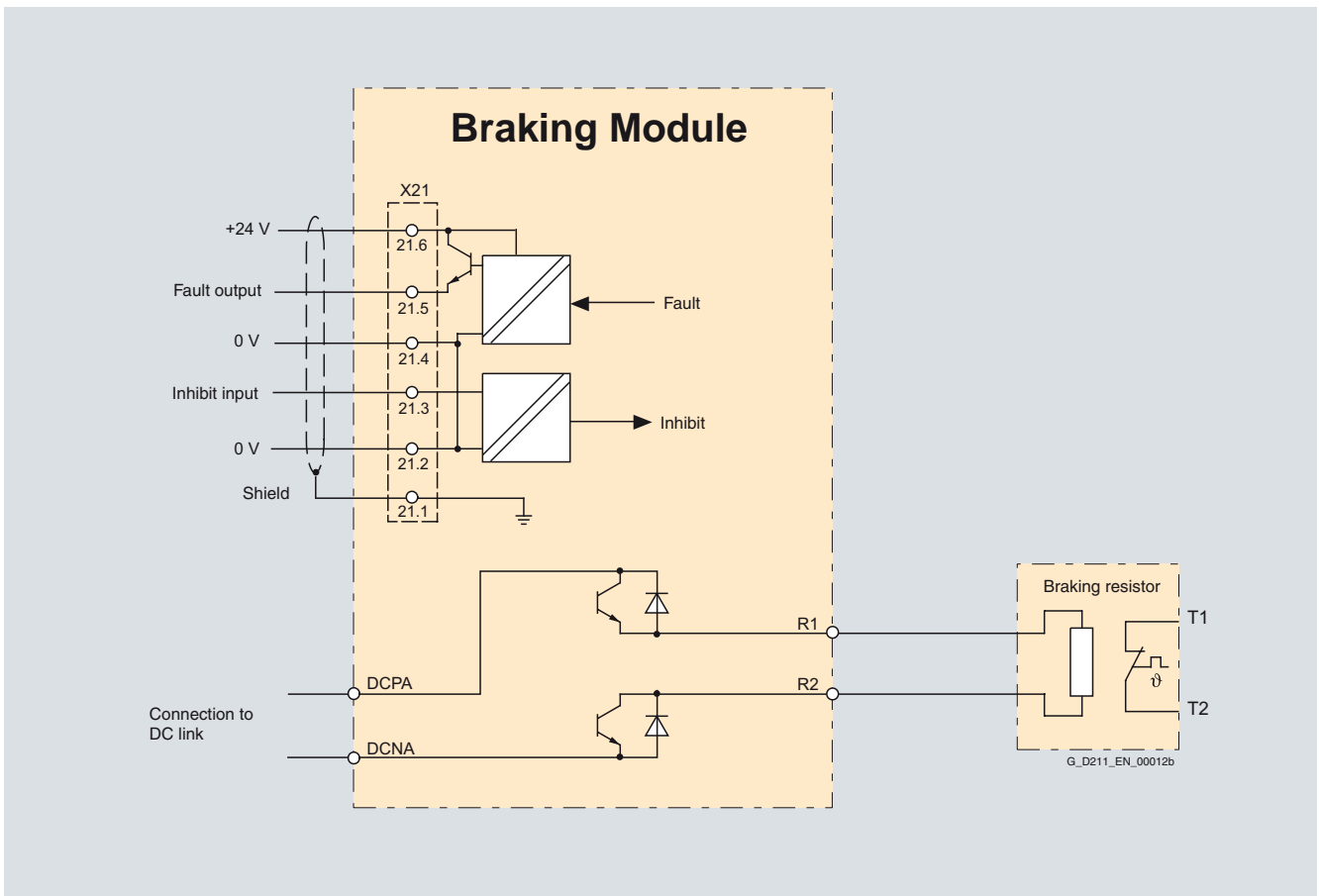

Connection example of a Braking Module

SINAMICS G120

Standard inverters 0.37 kW to 250 kW (0.5 hp to 400 hp)

DC link components
Braking Modules

Technical specifications

DC link voltage 510 ... 720 V DC	Braking Module 6SL3300-1AE32-5AA0
Power	
• Rated power P_{DB}	50 kW (67 hp)
• Peak power P_{15}	250 kW
• Power P_{20}	200 kW
• Power P_{40}	100 kW
Activation thresholds (adjustable via DIP switch)	774 V (factory setting) or 673 V
Length of cable to braking resistor, max.	50 m
Digital inputs In accordance with IEC 61131-2 Type 1	
• Voltage	-3 ... +30 V
• Low level (an open-circuit digital input is interpreted as "low")	-3 ... +5 V
• High Level	15 ... 30 V
• Current consumption at 24 V DC, typ.	10 mA
• Max. conductor cross-section	1.5 mm ²
Digital outputs (continuously short-circuit proof)	
• Voltage	24 V DC
• Load current per digital output, max.	500 mA
• Max. conductor cross-section	1.5 mm ²
R1/R2 connection	M8 screw
• Max. conductor cross-section	50 mm ²
Weight, approx.	7.3 kg
Approvals	cURus (File No.: E192450)
Suitable for installation in a PM240 Power Module	Frame size FSGX

SINAMICS G120

Standard inverters 0.37 kW to 250 kW (0.5 hp to 400 hp)

Load-side power components Output reactors

Overview

Output reactors reduce the voltage stress on the motor windings. At the same time, the capacitive charging/discharging currents, which place an additional load on the power unit when long motor cables are used, are reduced.

Output reactors are only provided for the PM240 and PM250 Power Modules. An output reactor is not required for the PM260 Power Module due to its integrated sine-wave filter.

The maximum permissible output frequency is 150 Hz when an output reactor is used – the pulse frequency must not exceed 4 kHz.

The output reactor must be installed as close as possible to the Power Module.

Output reactors are approved for use only in conjunction with "Vector" and "V/f control" modes.



Example: Output reactors for Power Modules frame sizes FSA and FSB



Example: Output reactor for PM240 Power Modules frame size FSGX

Selection and ordering data

Rated power		SINAMICS G120 PM240 Power Modules		Output reactor	
kW	hp	Type 6SL3224-...	Frame size	Order No.	
380 ... 480 V 3 AC					
0.37	0.50	OBE13-7UA0	FSA	6SE6400-3TC00-4AD2	
0.55	0.75	OBE15-5UA0	FSA		
0.75	1.0	OBE17-5UA0	FSA		
1.1	1.5	OBE21-1UA0	FSA		
1.5	2	OBE21-5UA0	FSA		
2.2	3	OBE22-2 . A0	FSB	6SL3202-0AE21-0CA0	
3.0	4	OBE23-0 . A0	FSB		
4.0	5	OBE24-0 . A0	FSB		
7.5	10	OBE25-5 . A0	FSC	6SL3202-0AJ23-2CA0	
11.0	15	OBE27-5 . A0	FSC		
15.0	20	OBE31-1 . A0	FSC	6SE6400-3TC05-4DD0	
18.5	25	OBE31-5 . A0	FSD		
22	30	OBE31-8 . A0	FSD	6SE6400-3TC03-8DD0	
30	40	OBE32-2 . A0	FSD		
37	50	OBE33-0 . A0	FSE	6SE6400-3TC08-0ED0	
45	60	OBE33-7 . A0	FSE		
55	75	OBE34-5 . A0	FSF	6SE6400-3TC14-5FD0	
75	100	OBE35-5 . A0	FSF		
90	125	OBE37-5 . A0	FSF	6SE6400-3TC14-5FD0	
110	150	OBE38-8UA0	FSF		
132	200	OBE41-1UA0	FSF	6SL3000-2BE32-1AA0	
160	250	OXE41-3UA0	FSGX		
200	300	OXE41-6UA0	FSGX	6SL3000-2BE33-8AA0	
250	400	OXE42-0UA0	FSGX		

Rated power		SINAMICS G120 PM250 Power Modules		Output reactor	
kW	hp	Type 6SL3225-...	Frame size	Order No.	
380 ... 480 V 3 AC					
7.5	10	OBE25-5AA0	FSC	6SL3202-0AJ23-2CA0	
11.0	15	OBE27-5AA0	FSC		
15.0	20	OBE31-1AA0	FSC		
18.5	25	OBE31-5 . A0	FSD	6SE6400-3TC05-4DD0	
22	30	OBE31-8 . A0	FSD		
30	40	OBE32-2 . A0	FSD	6SE6400-3TC05-4DD0	
37	50	OBE33-0 . A0	FSE		
45	60	OBE33-7 . A0	FSE	6SE6400-3TC08-0ED0	
55	75	OBE34-5 . A0	FSF		
75	100	OBE35-5 . A0	FSF	6SE6400-3TC14-5FD0	
90	125	OBE37-5 . A0	FSF		

SINAMICS G120

Standard inverters 0.37 kW to 250 kW (0.5 hp to 400 hp)

Load-side power components
Output reactors

Integration

Output reactors which are optionally available depending on the Power Module used

The following line-side power components, DC link components and load-side power components are optionally available in the appropriate frame sizes for the Power Modules:

	Frame size						
	FSA	FSB	FSC	FSD	FSE	FSF	FSGX
PM240 Power Module with integrated brake chopper							without integrated brake chopper
Available frame sizes	✓	✓	✓	✓	✓	✓	✓
Load-side power components							
Output reactor	U	U	U	S	S	S	S
PM250 Power Module with line-commutated energy recovery							
Available frame sizes	–	–	✓	✓	✓	✓	–
Load-side power components							
Output reactor	–	–	U	S	S	S	–
PM260 Power Module with line-commutated energy recovery and integrated sine-wave filter							
Available frame sizes	–	–	–	✓	–	✓	–
Load-side power components							
Output reactor ¹⁾	–	–	–	–	–	–	–

U = Base component
S = Lateral mounting
– = Not possible

¹⁾ PM260 Power Modules do not require output reactors as they are already equipped with sine-wave filters.

SINAMICS G120

Standard inverters 0.37 kW to 250 kW (0.5 hp to 400 hp)

Load-side power components Output reactors

Technical specifications

Line supply voltage 380 ... 480 V 3 AC		Output reactor (for a 4 kHz pulse frequency)				
		6SE6400-3TC00-4AD2				
Rated current	A	4	4	4	4	4
Power loss	kW	0.005	0.005	0.005	0.005	0.005
Connection to the Power Module		Cable	Cable	Cable	Cable	Cable
• Conductor cross-section		4 × AWG16 (1.5 mm ²)	4 × AWG16 (1.5 mm ²)	4 × AWG16 (1.5 mm ²)	4 × AWG16 (1.5 mm ²)	4 × AWG16 (1.5 mm ²)
• Length, approx.	m	0.3	0.3	0.3	0.3	0.3
Motor connection		Screw terminals	Screw terminals	Screw terminals	Screw terminals	Screw terminals
• Conductor cross-section	mm ²	6	6	6	6	6
PE connection		M5 screw studs	M5 screw studs	M5 screw studs	M5 screw studs	M5 screw studs
Cable length, max. between output reactor and motor						
• 380 V (– 10 %) ... 400 V 3 AC						
- Shielded	m	150	150	150	150	150
- Unshielded	m	225	225	225	225	225
• 401 V... 480 V (+ 10 %) 3 AC						
- Shielded	m	100	100	100	100	100
- Unshielded	m	150	150	150	150	150
Dimensions						
• Width	mm	75.5	75.5	75.5	75.5	75.5
• Height	mm	200	200	200	200	200
• Depth	mm	110	110	110	110	110
Possible as base component		yes	yes	yes	yes	yes
Degree of protection		IP00	IP00	IP00	IP00	IP00
Weight, approx.	kg	2	2	2	2	2
Suitable for PM240 Power Module	Type	6SL3224-0BE13-7UA0	6SL3224-0BE15-5UA0	6SL3224-0BE17-5UA0	6SL3224-0BE21-1UA0	6SL3224-0BE21-5UA0
Rated power of the Power Module	kW (hp)	0.37 (0.5)	0.55 (0.75)	0.75 (1.0)	1.1 (1.5)	1.5 (2.0)
Rated current I_{rated} of the Power Module	A	1.3	1.7	2.2	3.1	4.1
Frame size		FSA	FSA	FSA	FSA	FSA

4

SINAMICS G120

Standard inverters 0.37 kW to 250 kW (0.5 hp to 400 hp)

Load-side power components Output reactors

Technical specifications

Line supply voltage 380 ... 480 V 3 AC		Output reactor (for a 4 kHz pulse frequency)					
		6SL3202-0AE21-0CA0			6SL3202-0AJ23-2CA0		
Rated current	A	9.4	9.4	9.4	32	32	32
Power loss	kW	0.02	0.02	0.02	0.06	0.06	0.06
Connection to the Power Module		Cable	Cable	Cable	Cable	Cable	Cable
• Conductor cross-section		4 × AWG14 (1.5 mm ²)	4 × AWG14 (1.5 mm ²)	4 × AWG14 (1.5 mm ²)	4 × AWG14 (1.5 mm ²)	4 × AWG14 (1.5 mm ²)	4 × AWG14 (1.5 mm ²)
• Length, approx.	m	0.4	0.4	0.4	0.35	0.35	0.35
Motor connection		Screw terminals	Screw terminals	Screw terminals	Screw terminals	Screw terminals	Screw terminals
• Conductor cross-section	mm ²	6	6	6	6	6	6
PE connection		M5 screw studs	M5 screw studs	M5 screw studs	M5 screw studs	M5 screw studs	M5 screw studs
Cable length, max. between output reactor and motor							
• 380 V (-10 %) ... 400 V 3 AC							
- Shielded	m	150	150	150	150	150	150
- Unshielded	m	225	225	225	225	225	225
• 401 V ... 480 V (+10 %) 3 AC							
- Shielded	m	100	100	100	100	100	100
- Unshielded	m	150	150	150	150	150	150
Dimensions							
• Width	mm	154	154	154	189	189	189
• Height	mm	270	270	270	334	334	334
• Depth	mm	70	70	70	80	80	80
Possible as base component		yes	yes	yes	yes	yes	yes
Degree of protection		IP00	IP00	IP00	IP00	IP00	IP00
Weight, approx.	kg	4.4	4.4	4.4	9.1	9.1	9.1
Suitable for PM240 Power Module	Type	6SL3224-0BE22-2UA0 6SL3224-0BE22-2AA0	6SL3224-0BE23-0UA0 6SL3224-0BE23-0AA0	6SL3224-0BE24-0UA0 6SL3224-0BE24-0AA0	6SL3224-0BE25-5UA0 6SL3224-0BE25-5AA0	6SL3224-0BE27-5UA0 6SL3224-0BE27-5AA0	6SL3224-0BE31-1UA0 6SL3224-0BE31-1AA0
Suitable for PM250 Power Module	Type	–	–	–	6SL3225-0BE25-5AA0	6SL3225-0BE27-5AA0	6SL3225-0BE31-1AA0
Rated power of the Power Module	kW (hp)	2.2 (3.0)	3 (4)	4 (5)	7.5 (10)	11 (15)	15 (20)
Rated current I_{rated} of the Power Module	A	5.9	7.7	10.2	18	25	32
Frame size		FSB	FSB	FSB	FSC	FSC	FSC

SINAMICS G120

Standard inverters 0.37 kW to 250 kW (0.5 hp to 400 hp)

Load-side power components Output reactors

Technical specifications

Line supply voltage 380 ... 480 V 3 AC		Output reactor (for a 4 kHz pulse frequency)				
		6SE6400-3TC05-4DD0	6SE6400-3TC03-8DD0	6SE6400-3TC05-4DD0	6SE6400-3TC08-0ED0	6SE6400-3TC07-5ED0
Rated current	A	68 ¹⁾	45 ¹⁾	68 ¹⁾	104 ¹⁾	90 ¹⁾
Power loss	kW	0.2	0.2	0.2	0.17	0.27
Connection to the Power Module		Flat connector for M6 cable lug	Flat connector for M6 cable lug	Flat connector for M6 cable lug	Flat connector for M6 cable lug	Flat connector for M6 cable lug
Motor connection		Flat connector for M6 cable lug	Flat connector for M6 cable lug	Flat connector for M6 cable lug	Flat connector for M6 cable lug	Flat connector for M6 cable lug
PE connection		M6 screw	M6 screw	M6 screw	M6 screw	M6 screw
Cable length, max. between output reactor and motor						
• 380 V (- 10 %) ... 400 V 3 AC						
- Shielded	m	200	200	200	200	200
- Unshielded	m	300	300	300	300	300
• 401 V ... 480 V (+ 10 %) 3 AC						
- Shielded	m	200	200	200	200	200
- Unshielded	m	300	300	300	300	300
Dimensions						
• Width	mm	225	225	225	225	270
• Height	mm	210	210	210	210	248
• Depth	mm	150	179	150	150	209
Possible as base component		no	no	no	no	no
Degree of protection		IP00	IP00	IP00	IP00	IP00
Weight, approx.	kg	10.7	16.1	10.7	10.4	24.9
Suitable for PM240 Power Module	Type	6SL3224-0BE31-5UA0 6SL3224-0BE31-5AA0	6SL3224-0BE31-8UA0 6SL3224-0BE31-8AA0	6SL3224-0BE32-2UA0 6SL3224-0BE32-2AA0	6SL3224-0BE33-0UA0 6SL3224-0BE33-0AA0	6SL3224-0BE33-7UA0 6SL3224-0BE33-7AA0
Suitable for PM250 Power Module	Type	6SL3225-0BE31-5 . A0	6SL3225-0BE31-8 . A0	6SL3225-0BE32-2 . A0	6SL3225-0BE33-0 . A0	6SL3225-0BE33-7 . A0
Rated power of the Power Module	kW (hp)	18.5 (25)	22 (30)	30 (40)	37 (50)	45 (60)
Rated current I_{rated} of the Power Module	A	38	45	60	75	90
Frame size		FSD	FSD	FSD	FSE	FSE

¹⁾ On the rating plate of the reactor the current is displayed according to High Overload HO, which is lower than the indicated value for the Light Overload current of the Power Module.

SINAMICS G120

Standard inverters 0.37 kW to 250 kW (0.5 hp to 400 hp)

Load-side power components Output reactors

Technical specifications

Line supply voltage 380 ... 480 V 3 AC		Output reactor (for a 4 kHz pulse frequency)				
		6SE6400-3TC14-5FD0	6SE6400-3TC15-4FD0	6SE6400-3TC14-5FD0	6SL3000-2BE32-1AA0	6SL3000-2BE32-6AA0
Rated current	A	178 ¹⁾	178 ¹⁾	178 ¹⁾	210	260
Power loss	kW	0.47	0.25	0.47	0.49	0.5
Connection to the Power Module		Flat connector for M8 cable lug	Flat connector for M8 cable lug	Flat connector for M8 cable lug	Flat connector for M10 screw	Flat connector for M10 screw
Motor connection		Flat connector for M8 cable lug	Flat connector for M8 cable lug	Flat connector for M8 cable lug	Flat connector for M10 screw	Flat connector for M10 screw
PE connection		M8 screw	M6 screw	M8 screw	M8 screw	M8 screw
Cable length, max. between output reactor and motor						
• 380 V (- 10 %) ... 400 V 3 AC						
- Shielded	m	200	200	200	200	200
- Unshielded	m	300	300	300	300	300
• 401 V ... 480 V (+ 10 %) 3 AC						
- Shielded	m	200	200	200	200	200
- Unshielded	m	300	300	300	300	300
Dimensions						
• Width	mm	350	270	350	300	300
• Height	mm	321	248	321	285	315
• Depth	mm	288	209	288	257	277
Possible as base component		no	no	no	no	no
Degree of protection		IP00	IP00	IP00	IP00	IP00
Weight, approx.	kg	51.5	24	51.5	60	66
Suitable for PM240 Power Module	Type	6SL3224-0BE34-5UA0 6SL3224-0BE34-5AA0	6SL3224-0BE35-5UA0 6SL3224-0BE35-5AA0	6SL3224-0BE37-5UA0 6SL3224-0BE37-5AA0	6SL3224-0BE38-8UA0	6SL3224-0BE41-1UA0
Suitable for PM250 Power Module	Type	6SL3225-0BE34-5 . A0	6SL3225-0BE35-5 . A0	6SL3225-0BE37-5 . A0	-	-
Rated power of the Power Module	kW (hp)	55 (75)	75 (100)	90 (125)	110 (150)	132 (200)
Rated current I_{rated} of the Power Module	A	110	145	178	205	250
Frame size		FSF	FSF	FSF	FSF	FSF

¹⁾ On the rating plate of the reactor the current is displayed according to High Overload HO, which is lower than the indicated value for the Light Overload current of the Power Module.

SINAMICS G120

Standard inverters 0.37 kW to 250 kW (0.5 hp to 400 hp)

Load-side power components Output reactors

Technical specifications

Line supply voltage 380 ... 480 V 3 AC		Output reactor (for a 4 kHz pulse frequency)		
		6SL3000-2BE33-2AA0	6SL3000-2BE33-8AA0	6SL3000-2BE35-0AA0
Rated current	A	310	380	490
Power loss	kW	0.470	0.500	0.500
Connection to the Power Module		1 × hole for M10	1 × hole for M10	1 × hole for M12
Motor connection		1 × hole for M10	1 × hole for M10	1 × hole for M12
PE connection		M6 screw	M6 screw	M6 screw
Cable length, max. between output reactor and motor				
• 380 V (– 10 %) ... 400 V 3 AC				
- Shielded	m	300	300	300
- Unshielded	m	450	450	450
• 401 V ... 480 V (+ 10 %) 3 AC				
- Shielded	m	300	300	300
- Unshielded	m	450	450	450
Dimensions				
• Width	mm	300	300	300
• Height	mm	285	285	365
• Depth	mm	257	277	277
Possible as base component		no	no	no
Degree of protection		IP00	IP00	IP00
Weight, approx.	kg	66	73	100
Suitable for PM240 Power Module	Type	6SL3224-0XE41-3UA0	6SL3224-0XE41-6UA0	6SL3224-0XE42-0UA0
Suitable for PM250 Power Module	Type	–	–	–
Rated power of the Power Module	kW (hp)	160 (250)	200 (300)	250 (400)
Rated current I_{rated} of the Power Module	A	302	370	477
Frame size		FSGX	FSGX	FSGX

Standard inverters 0.37 kW to 250 kW (0.5 hp to 400 hp)

Load-side power components
Sine-wave filters

Overview



Example: Sine-wave filter for PM240 Power Modules frame size FSGX

A sine-wave filter limits the rate of rise of voltage and the capacitive charging/discharging currents that usually occur with inverter operation. An output reactor is not required. Sine-wave filters are only provided for the PM240 and PM250 Power Modules. PM260 Power Modules already have an integrated sine-wave filter and an additional sine-wave filter is not required.

The sine-wave filter at the inverter output supplies almost perfect sinusoidal voltages at the motor so that standard motors can be used without special cables. Standard cables can be used. The maximum permissible motor feeder length is 300 m. The maximum output frequency is 150 Hz at 380 V to 480 V.

When using sine-wave filters, the following should be observed:

- Operation with pulse frequencies from 4 kHz to 8 kHz (sine-wave filter from 160 kW, only for 4 kHz) permissible
- It must be ensured that the automatic pulse frequency reduction functions are also deactivated
- A derating of 5 % must be observed when selecting a suitable inverter
- The output frequency is limited to 150 Hz
- Operation and commissioning may only be performed with the motor connected as the sine-wave filter is not no-load proof

Selection and ordering data

Rated power		SINAMICS G120 PM240 Power Module		Sine-wave filter	
kW	hp	Type 6SL3224-...	Frame size		Order No.
380 ... 480 V 3 AC					
0.37	0.50	OBE13-7UA0	FSA	new	6SL3202-0AE20-3SA0
0.55	0.75	OBE15-5UA0	FSA		
0.75	1.0	OBE17-5UA0	FSA		
1.1	1.5	OBE21-1UA0	FSA	new	6SL3202-0AE20-6SA0
1.5	2.0	OBE21-5UA0	FSA		
2.2	3.0	OBE22-2 . A0	FSB	new	6SL3202-0AE21-1SA0
3.0	4.0	OBE23-0 . A0	FSB		
4.0	5.0	OBE24-0 . A0	FSB	new	6SL3202-0AE21-4SA0
7.5	10	OBE25-5 . A0	FSC	new	6SL3202-0AE22-0SA0
11.0	15	OBE27-5 . A0	FSC	new	6SL3202-0AE23-3SA0
15.0	20	OBE31-1 . A0	FSC		
18.5	25	OBE31-5 . A0	FSD	new	6SL3202-0AE24-6SA0
22	30	OBE31-8 . A0	FSD		
30	40	OBE32-2 . A0	FSD	new	6SL3202-0AE26-2SA0
37	50	OBE33-0 . A0	FSE	new	6SL3202-0AE28-8SA0
45	60	OBE33-7 . A0	FSE		
55	75	OBE34-5 . A0	FSF	new	6SL3202-0AE31-5SA0
75	100	OBE35-5 . A0	FSF		
90	125	OBE37-5 . A0	FSF	new	6SL3202-0AE31-8SA0
110	150	OBE38-8UA0	FSF	new	6SL3000-2CE32-3AA0
132	200	OBE41-1UA0	FSF		
160	250	OXE41-3UA0	FSGX	new	6SL3000-2CE32-8AA0
200	300	OXE41-6UA0	FSGX	new	6SL3000-2CE33-3AA0
250	400	OXE42-0UA0	FSGX	new	6SL3000-2CE34-1AA0

Rated power		SINAMICS G120 PM250 Power Module		Sine-wave filter	
kW	hp	Type 6SL3225-...	Frame size		Order No.
380 ... 480 V 3 AC					
7.5	10	OBE25-5AA0	FSC	new	6SL3202-0AE22-0SA0
11.0	15	OBE27-5AA0	FSC	new	6SL3202-0AE23-3SA0
15.0	20	OBE31-1AA0	FSC		
18.5	25	OBE31-5 . A0	FSD	new	6SL3202-0AE24-6SA0
22	30	OBE31-8 . A0	FSD		
30	40	OBE32-2 . A0	FSD	new	6SL3202-0AE26-2SA0
37	50	OBE33-0 . A0	FSE	new	6SL3202-0AE28-8SA0
45	60	OBE33-7 . A0	FSE		
55	75	OBE34-5 . A0	FSF	new	6SL3202-0AE31-5SA0
75	100	OBE35-5 . A0	FSF		
90	125	OBE37-5 . A0	FSF	new	6SL3202-0AE31-8SA0

SINAMICS G120

Standard inverters 0.37 kW to 250 kW (0.5 hp to 400 hp)

Load-side power components Sine-wave filters

Integration

Sine-wave filters which are optionally available depending on the Power Module used

	Frame size							FSGX
	FSA	FSB	FSC	FSD	FSE	FSF		
PM240 Power Module with integrated brake chopper								without integrated brake chopper
Available frame sizes	✓	✓	✓	✓	✓	✓	✓	✓
Load-side power components								
Sine-wave filter	U	U	U	S	S	S	S	S
PM250 Power Module with line-commutated energy recovery								
Available frame sizes	–	–	✓	✓	✓	✓	–	–
Load-side power components								
Sine-wave filter	–	–	U	S	S	S	–	–
PM260 Power Module with line-commutated energy recovery and integrated sine-wave filter								
Available frame sizes	–	–	–	✓	–	✓	–	–
Load-side power components								
Sine-wave filter	–	–	–	I	–	I	–	–

U = Base component
S = Lateral mounting
I = Integrated
– = Not possible

SINAMICS G120

Standard inverters 0.37 kW to 250 kW (0.5 hp to 400 hp)

Load-side power components
Sine-wave filters

Technical specifications

Line supply voltage 380 ... 480 V 3 AC		Sine-wave filter (for pulse frequencies 4 kHz ... 8 kHz)				
		6SL3202-0AE20-3SA0			6SL3202-0AE20-6SA0	
Rated current	A	3.5	3.5	3.5	6.0	6.0
Power loss	kW	0.005	0.005	0.005	0.005	0.005
Connection to the Power Module		Cable	Cable	Cable	Cable	Cable
• Conductor cross-section	mm ²	6	6	6	6	6
• Length, approx.	m	0.5	0.5	0.5	0.5	0.5
Motor connection		Screw terminals	Screw terminals	Screw terminals	Screw terminals	Screw terminals
• Conductor cross-section	mm ²	6	6	6	6	6
PE connection		M5 screw studs	M5 screw studs	M5 screw studs	M5 screw studs	M5 screw studs
Cable length, max. between sine-wave filter and motor						
• 380 ... 480 V 3 AC ±10 %						
- Shielded	m	200	200	200	200	200
- Unshielded	m	300	300	300	300	300
Dimensions						
• Width	mm	75.5	75.5	75.5	75.5	75.5
• Height	mm	200	200	200	200	200
• Depth	mm	110	110	110	110	110
Possible as base component		yes	yes	yes	yes	yes
Degree of protection		IP20	IP20	IP20	IP20	IP20
Weight, approx.	kg	2.6	2.6	2.6	3.0	3.0
Suitable for PM240 Power Module	Type	6SL3224-0BE13-7UA0	6SL3224-0BE15-5UA0	6SL3224-0BE17-5UA0	6SL3224-0BE21-1UA0	6SL3224-0BE21-5UA0
Rated power of the Power Module	kW (hp)	0.37 (0.5)	0.55 (0.75)	0.75 (1.0)	1.1 (1.5)	1.5 (2.0)
Rated current I_{rated} of the Power Module	A	1.3	1.7	2.2	3.1	4.1
Frame size		FSA	FSA	FSA	FSA	FSA

SINAMICS G120

Standard inverters 0.37 kW to 250 kW (0.5 hp to 400 hp)

Load-side power components Sine-wave filters

Technical specifications

Line supply voltage 380 ... 480 V 3 AC		Sine-wave filter (for pulse frequencies 4 kHz ... 8 kHz)					
		6SL3202-0AE21-1SA0		6SL3202-0AE21-4SA0	6SL3202-0AE22-0SA0	6SL3202-0AE23-3SA0	
Rated current	A	9.0	9.0	14.0	20.0	33.0	33.0
Power loss	kW	0.02	0.02	0.02	0.06	0.06	0.06
Connection to the Power Module		Cable	Cable	Cable	Cable	Cable	Cable
• Conductor cross-section	mm ²	6	6	6	10	10	10
• Length, approx.	m	0.5	0.5	0.5	0.5	0.5	0.5
Motor connection		Screw terminals	Screw terminals	Screw terminals	Screw terminals	Screw terminals	Screw terminals
• Conductor cross-section	mm ²	6	6	6	10	10	10
PE connection		M5 screw studs	M5 screw studs	M5 screw studs	M5 screw studs	M5 screw studs	M5 screw studs
Cable length, max. between sine-wave filter and motor							
• 380 ... 480 V 3 AC ±10 %							
- Shielded	m	200	200	200	200	200	200
- Unshielded	m	300	300	300	300	300	300
Dimensions							
• Width	mm	153	153	153	189	189	189
• Height	mm	270	270	270	336	336	336
• Depth	mm	100	100	100	140	140	140
Possible as base component		yes	yes	yes	yes	yes	yes
Degree of protection		IP20	IP20	IP20	IP20	IP20	IP20
Weight, approx.	kg	6	6	10	12	23	23
Suitable for PM240 Power Module	Type	6SL3224-0BE22-2UA0 6SL3224-0BE22-2AA0	6SL3224-0BE23-0UA0 6SL3224-0BE23-0AA0	6SL3224-0BE24-0UA0 6SL3224-0BE24-0AA0	6SL3224-0BE25-5UA0 6SL3224-0BE25-5AA0	6SL3224-0BE27-5UA0 6SL3224-0BE27-5AA0	6SL3224-0BE31-1UA0 6SL3224-0BE31-1AA0
Suitable for PM250 Power Module	Type	–	–	–	6SL3225-0BE25-5AA0	6SL3225-0BE27-5AA0	6SL3225-0BE31-1AA0
Rated power of the Power Module	kW (hp)	2.2 (3)	3 (4)	4 (5)	7.5 (10)	11 (15)	15 (20)
Rated current I_{rated} of the Power Module	A	5.9	7.7	10.2	18	25	32
Frame size		FSB	FSB	FSB	FSC	FSC	FSC

SINAMICS G120

Standard inverters 0.37 kW to 250 kW (0.5 hp to 400 hp)

Load-side power components
Sine-wave filters

Technical specifications

Line supply voltage 380 ... 480 V 3 AC		Sine-wave filter (for pulse frequencies 4 kHz ... 8 kHz)				
		6SL3202-0AE24-6SA0		6SL3202-0AE26-2SA0	6SL3202-0AE28-8SA0	
Rated current	A	47	47	61.8	92	92
Power loss	kW	0.2	0.2	0.2	0.17	0.27
Connection to the Power Module		Screw terminals	Screw terminals	Screw terminals	Screw terminals	Screw terminals
• Conductor cross-section	mm ²	50	50	50	95	95
Motor connection		Screw terminals	Screw terminals	Screw terminals	Screw terminals	Screw terminals
• Conductor cross-section	mm ²	50	50	50	95	95
PE connection		M6 screw	M6 screw	M6 screw	M8 screw	M8 screw
Cable length, max. between sine-wave filter and motor						
• 380 ... 480 V 3 AC ±10 %						
- Shielded	m	200	200	200	200	200
- Unshielded	m	300	300	300	300	300
Dimensions						
• Width	mm	250	250	250	275	275
• Height	mm	315	315	305	368	368
• Depth	mm	262	262	262	275	275
Possible as base component		no	no	no	no	no
Degree of protection		IP00	IP00	IP00	IP00	IP00
Weight, approx.	kg	24.0	24.0	34.0	45.0	45.0
Suitable for PM240 Power Module	Type	6SL3224-0BE31-5UA0 6SL3224-0BE31-5AA0	6SL3224-0BE31-8UA0 6SL3224-0BE31-8AA0	6SL3224-0BE32-2UA0 6SL3224-0BE32-2AA0	6SL3224-0BE33-0UA0 6SL3224-0BE33-0AA0	6SL3224-0BE33-7UA0 6SL3224-0BE33-7AA0
Suitable for PM250 Power Module	Type	6SL3225-0BE31-5 . A0	6SL3225-0BE31-8 . A0	6SL3225-0BE32-2 . A0	6SL3225-0BE33-0 . A0	6SL3225-0BE33-7 . A0
Rated power of the Power Module	kW (hp)	18.5 (25)	22 (30)	30 (40)	37 (50)	45 (60)
Rated current I_{rated} of the Power Module	A	38	45	60	75	90
Frame size		FSD	FSD	FSD	FSE	FSE

SINAMICS G120

Standard inverters 0.37 kW to 250 kW (0.5 hp to 400 hp)

Load-side power components Sine-wave filters

Technical specifications

Line supply voltage 380 ... 480 V 3 AC		Sine-wave filter (for pulse frequencies 4 kHz ... 8 kHz, from 160 kW only 4 kHz)				
		6SL3202-0AE31-5SA0		6SL3202-0AE31-8SA0	6SL3000-2CE32-3AA0	
Rated current	A	150	150	182	225	225
Power loss	kW	0.47	0.25	0.47	0.6	0.6
Connection to the Power Module		Screw terminals	Screw terminals	Screw terminals	1 × hole for M10	1 × hole for M10
• Conductor cross-section	mm ²	150	150	150		
Motor connection		Screw terminals	Screw terminals	Screw terminals	1 × hole for M10	1 × hole for M10
• Conductor cross-section	mm ²	150	150	150		
PE connection		M8 screw	M6 screw	M8 screw	1 × hole for M10	1 × hole for M10
Cable length, max. between sine-wave filter and motor						
• 380 ... 480 V 3 AC ±10 %						
- Shielded	m	200	200	200	300	300
- Unshielded	m	300	300	300	450	450
Dimensions						
• Width	mm	350	350	350	620	620
• Height	mm	440	440	468	300	300
• Depth	mm	305	305	305	320	320
Possible as base component		no	no	no	no	no
Degree of protection		IP00	IP00	IP00	IP00	IP00
Weight, approx.	kg	63.0	63.0	80.0	124	124
Suitable for PM240 Power Module	Type	6SL3224-0BE34-5UA0 6SL3224-0BE34-5AA0	6SL3224-0BE35-5UA0 6SL3224-0BE35-5AA0	6SL3224-0BE37-5UA0 6SL3224-0BE37-5AA0	6SL3224-0BE38-8UA0	6SL3224-0BE41-1UA0
Suitable for PM250 Power Module	Type	6SL3225-0BE34-5 . A0	6SL3225-0BE35-5 . A0	6SL3225-0BE37-5 . A0	–	–
Rated power of the Power Module	kW (hp)	55 (75)	75 (100)	90 (125)	110 (150)	132 (200)
Rated current I_{rated} of the Power Module	A	110	145	178	205	250
Frame size		FSF	FSF	FSF	FSF	FSF

SINAMICS G120

Standard inverters 0.37 kW to 250 kW (0.5 hp to 400 hp)

Load-side power components
Sine-wave filters

Technical specifications

Line supply voltage 380 ... 480 V 3 AC		Sine-wave filter (for pulse frequencies 4 kHz ... 8 kHz, from 160 kW only 4 kHz)		
		6SL3000-2CE32-8AA0	6SL3000-2CE33-3AA0	6SL3000-2CE34-1AA0
Rated current	A	276	333	408
Power loss	kW	0.69	0.53	0.7
Connection to the Power Module		1 × hole for M10	1 × hole for M10	1 × hole for M10
Motor connection		1 × hole for M10	1 × hole for M10	1 × hole for M10
PE connection		1 × hole for M10	1 × hole for M10	1 × hole for M10
Cable length, max. between sine-wave filter and motor				
• 380 ... 480 V 3 AC ±10 %				
- Shielded	m	300	300	300
- Unshielded	m	450	450	450
Dimensions				
• Width	mm	620	620	620
• Height	mm	300	370	370
• Depth	mm	320	360	360
Possible as base component		no	no	no
Degree of protection		IP00	IP00	IP00
Weight, approx.	kg	127	136	198
Suitable for PM240 Power Module	Type	6SL3224-0XE41-3UA0	6SL3224-0XE41-6UA0	6SL3224-0XE42-0UA0
Suitable for PM250 Power Module	Type	–	–	–
Rated power of the Power Module	kW (hp)	160 (250)	200 (300)	250 (400)
Rated current I_{rated} of the Power Module	A	302	370	477
Frame size		FSGX	FSGX	FSGX

SINAMICS G120

Standard inverters 0.37 kW to 250 kW (0.5 hp to 400 hp)

Supplementary system components Intelligent Operator Panel IOP

Overview

Intelligent Operator Panel IOP



The Intelligent Operator Panel IOP is an extremely user-friendly and powerful Operator Panel for the SINAMICS G120, SINAMICS G120D standard drives and SIMATIC ET 200 frequency converters.

The IOP supports both entry-level personnel and drive experts. Thanks to the large plain text display, the menu prompting and the Application Wizards, it is easy to commission standard drives. A drive can be essentially commissioned without having to use a printed parameter list as the parameters are displayed in plain text and due to the explanatory help texts and the parameter filtering function.

Application Wizards interactively guide you when commissioning important applications such as conveyor technology, pumps, fans and compressors. There are quick commissioning wizards for general commissioning.

The drives are manually and simply controlled using directly assigned buttons and the navigation wheel. The IOP has a dedicated switchover button to switch over from the automatic to the manual mode.

The frequency inverter can be diagnosed in a user-friendly fashion using the plain text display of faults and alarms. Help texts can be obtained by pressing the INFO button.

Up to two process values can either be graphically or numerically visualized on the status screen/status display. Process values can also be displayed in technological units.

IOP supports series commissioning of identical drives. For this purpose, a parameter list can be copied from a frequency inverter into the IOP and when required, downloaded into other drive units of the same type.

The IOP includes the following language packages: English, French, German, Italian and Spanish.

The IOP can be installed in control cabinet doors using the optionally available door mounting kit.

Updating the IOP

The IOP can be updated and expanded using the integrated USB interface. Data to support future drive systems can be transferred from the PC to the IOP via drag & drop. Further, the USB interface allows user languages and wizards that become available in the future to be subsequently downloaded and the firmware to be updated for the IOP. The IOP is supplied with power via the USB interface during an update.

IOP Handheld



A handheld version of the IOP can be ordered for mobile use. In addition to the IOP, this includes a housing with rechargeable batteries, charging unit and RS232 interface cable. The charging unit is supplied with connector adapters for Europe, the US and UK. When the batteries are fully charged, the operating time is up to 8 hours.

A PC Inverter Connection Kit 6SL3255-0AA00-2AA1 is required to connect the IOP to the CU240S and CU240E Control Units.

To connect the IOP Handheld to SINAMICS G110D and SINAMICS G120D, the RS232 interface cable with optical interface is additionally required.

Benefits

- Simple commissioning of standard applications using wizards, it is not necessary to know the parameter structure
- Diagnostics using plain text display; can be used locally on-site without documentation
- Direct manual operation of the drive – you can toggle between the automatic and manual modes
- Status display with freely selectable units; display of real physical values
- Intuitive, navigation using a wheel – just like in everyday applications
- Graphic display for e.g. status values in bar-type diagrams such as e.g. pressure, flow
- Quickly and simply mounted in the door – mechanically and electrically
- Simple local commissioning on-site using the handheld version
- Commissioning without documentation using the integrated help function
- Series commissioning using the clone function (parameter set data is saved for fast replacement)
- User-defined parameter list with a reduced number of self-selected parameters (to generate your own commissioning screens)
- 5 integrated languages
- Simple update of languages, wizards and firmware updates via USB

Selection and ordering data

Designation	Order No.
Intelligent Operator Panel IOP	new 6SL3255-0AA00-4JA0
IOP Handheld	new 6SL3255-0AA00-4HA0
For use with SINAMICS G120, SINAMICS G110D, SINAMICS G120D, SIMATIC ET 200S FC or SIMATIC ET 200pro FC	
Included in the scope of delivery:	
<ul style="list-style-type: none"> • IOP • Handheld housing • Rechargeable batteries (4 × AA) • Charging unit (international) • RS232 connecting cable (3 m long, can only be used for SINAMICS G120 and SIMATIC ET 200S FC) • USB cable (1 m long) 	

Accessories

Designation	Order No.
IOP Door Mounting Kit	new 6SL3256-0AP00-0JA0
IP54 degree of protection for mounting the IOP in control cabinet doors with sheet steel thicknesses of 1 ... 3 mm	
Included in the scope of delivery:	
<ul style="list-style-type: none"> • Seal • Mounting material • Connecting cable (5 m long) 	
RS232 interface cable	3RK1922-2BP00
With optical interface to connect the SINAMICS G110D, SINAMICS G120D or SIMATIC ET 200pro FC inverters to the IOP Handheld (2.5 m long)	

Integration

Using the IOP with the frequency inverters

IOP	SINAMICS G120 with CU230P-2 Control Unit	SINAMICS G120 with CU240E or CU240S Control Unit	SINAMICS G110D and SINAMICS G120D
Plugging the IOP onto the inverter (power supply from the Control Unit)	✓	–	–
IOP door mounting with door mounting kit (power supply from the Control Unit)	✓	–	–
Mobile use of the IOP Handheld (supplied from rechargeable batteries)	✓	✓ PC Inverter Connection Kit required, 6SL3255-0AA00-2AA1	✓ RS232 interface cable with optical interface required, 3RK1922-2BP00

Mounting the IOP on a CU230P-2 Control Unit

The IOP can be directly plugged onto the CU230P-2 Control Unit.



CU230P-2 Control Unit with plugged on IOP

Mounting the IOP in a door

Using the optionally available door mounting kit, the IOP can be simply mounted in a control cabinet door with just a few manual operations (presently only available in conjunction with the SINAMICS G120 and CU230P-2 Control Unit). Degree of protection IP54/UL Type 12 is achieved when mounting in a door.

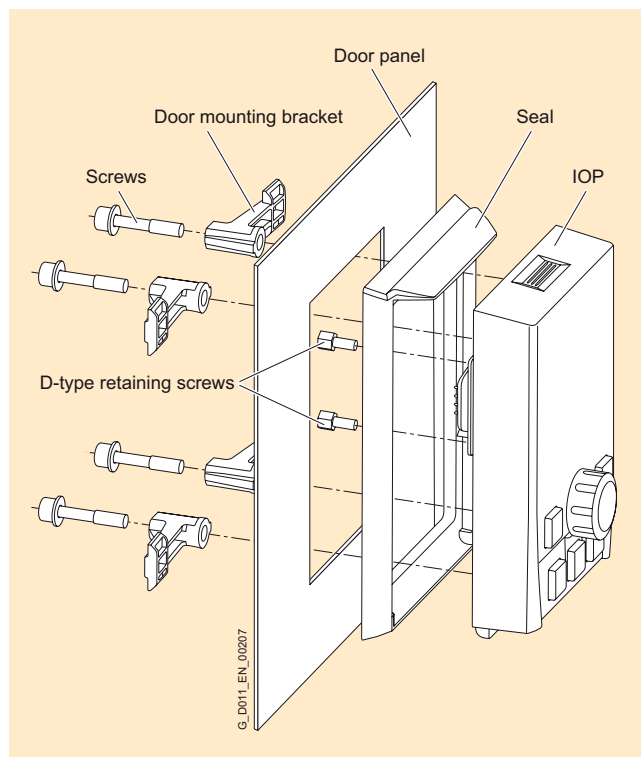

SINAMICS G120

Standard inverters 0.37 kW to 250 kW (0.5 hp to 400 hp)

Supplementary system components Basic Operator Panel BOP

Overview



The Basic Operator Panel BOP can be used to commission drives, monitor drives in operation and input individual parameter settings.

Values and units are displayed on a 5-digit display.

One BOP can be used for several inverters. It is plugged directly onto the CU240 Control Unit.

The BOP provides a function to quickly copy parameters. A parameter set of an inverter can be saved in the BOP and then downloaded to another inverter.

Note: The BOP is not suitable for the CU230P-2 Control Unit. The Intelligent Operator Panel IOP is available for this purpose.

Selection and ordering data

	Order No.
Basic Operator Panel BOP (not for Control Unit CU230P-2)	6SL3255-0AA00-4BA1

Integration



Example: CU240E Control Unit with mounted Basic Operator Panel BOP

SINAMICS G120

Standard inverters 0.37 kW to 250 kW (0.5 hp to 400 hp)

Supplementary system components
MMC memory card

Overview



The parameter settings for an inverter can be stored on the MMC memory card. When service is required, e.g. after the inverter has been replaced and the data have been downloaded from the memory card the drive system is immediately ready for use again.

- Parameter settings can be written from the MMC memory card to the inverter or saved from the inverter to the MMC memory card.
- Up to 100 parameter sets can be stored.
- Supports series commissioning without the use of additional commissioning tools (e.g. BOP and STARTER).
- Commissioning with the MMC memory card is defined by the user:
 - Parameter p8458 = 0 → parameter set 0 is never automatically downloaded from the MMC ("never")
 - Parameter p8458 = 1 → parameter set 0 is downloaded once after PowerOn ("once")
 - Parameter p8458 = 2 → parameter set 0 is always downloaded after PowerOn ("always")

Note:

The MMC memory card is not required for operation and does not have to remain inserted.

Note:

The CU240E Control Unit does not have a slot for the MMC memory card.

Integration



Example: Inserting the MMC memory card into a CU240 Control Unit



Example: CU240 Control Unit with inserted MMC memory card

Selection and ordering data

	Order No.
MMC memory card (not for the CU240E Control Unit)	6SL3254-0AM00-0AA0

SINAMICS G120

Standard inverters 0.37 kW to 250 kW (0.5 hp to 400 hp)

Supplementary system components CM240NE chemical industry module

Applications

Inverters for 400 V, 500 V and 690 V are required in the chemical industry that meet the special demands and requirements of this industry sector. The essential requirements and demands of the chemical industry are fulfilled using the SINAMICS G120 series of inverters supplemented by the CM240NE chemical industry module (with ATEX-certified PTC evaluation and a NAMUR terminal strip).



CM240NE chemical industry module

- Sine-wave filter integrated in the PM260 Power Modules (500 V to 690 V)
- A line reactor is not required for the PM260 and PM250 Power Modules
- PM250 and PM260 Power Modules are capable of energy recovery
- A series of inverters for the complete voltage and power range
- The integrated or external sine-wave filter permits unshielded motor cables up to 300 m; shielded motor cables are possible up to 200 m (carefully observe the max. length of the temperature sensor cable!)
- An extremely compact overall drive system can be achieved when using a PM260 Power Module, frame size FSD or FSF (the line reactor and sine-wave filter are not required, the chemical industry module is directly snapped onto the Power Module).



CM240NE chemical industry module without cover

Selection and ordering data

	Order No.
CM240NE chemical industry module new	6SL3255-0BT01-0PA0

Accessories

	Order No.
Supplementary kit for rail mounting comprising	new 6SL3260-4TA00-1AA6
<ul style="list-style-type: none"> • Adapter for rail mounting (acc. to DIN 50022, 35 × 15 mm) • Long cable harness 	

Design

- Compact, modular inverter
- Isolated analog inputs and outputs in the chemical industry module (1 setpoint / 2 measured values)
- Isolated digital inputs and outputs in the Control Unit
- Protective separation of the motor sensor cable with respect to the enclosure and other connections using reinforced insulation of the creepage and clearances (rated impulse voltage 12 kV) acc. to EN 60664 1
- Certified power disconnection (94/9/EC, ATEX) of the inverter without main contactor
- Forced inverter inhibit (EMERGENCY STOP function via STO)
- Terminal strip acc. to NE37, if fulfilled

The CM240NE chemical industry module has the following interfaces:

Designation	Description
PROFIBUS	9-pin, Sub-D connector or socket to connect PROFIBUS
X11 and X12	Parallel connection of the CM240NE chemical industry module with the Control Unit
X2	Terminal strip in accordance with NAMUR recommendation NE37 (2.5 mm ² screw terminals) <ul style="list-style-type: none"> • Digital inputs and outputs • Analog inputs and outputs
X3	Terminal strip in accordance with NAMUR recommendation NE37 (2.5 mm ² screw terminals) to connect the motor temperature sensor

Function

- Thermal motor protection (TMP) using the the PTC thermistor integrated in the motor (incl. protective separation up to 690 V line supplies)
- The analog inputs and outputs are electrically isolated (MW1 to 3)
- Provision of NAMUR terminal strip (-X2; -X3)

Integration

A chemical industry inverter comprises a SINAMICS G120 inverter (Power Module and Control Unit) and the CM240NE chemical industry module.

The CU240S DP-F is suitable as Control Unit. This is a Control Unit with integrated safety-oriented functions and PROFIBUS-DP interface.

The following Power Module versions are used:

- PM240 Power Module with DC braking function and brake chopper, 400 V line supply voltage
- PM250 Power Module with energy recovery capability, 400 V line supply voltage
- PM260 Power Module with energy recovery capability, 500 V to 690 V line supply voltage

Depending on the power unit, additional components may be necessary to complete the system.



Chemical industry inverter comprising PM240 Power Module, CU240S DP-F Control Unit with BOP and CM240NE chemical industry module

Additional information

A script file to parameterize the interconnections in line with the NAMUR assignment is available as download to commission the system using the STARTER commissioning tool.

German:

<http://support.automation.siemens.com/WW/view/de/30814192>

English:

<http://support.automation.siemens.com/WW/view/en/30814192>

SINAMICS G120

Standard inverters 0.37 kW to 250 kW (0.5 hp to 400 hp)

Supplementary system components PC Inverter Connection Kit -2

Overview

For controlling and commissioning an inverter directly from a PC, if the STARTER commissioning tool has been installed on the PC. With these, the inverter can be

- parameterized (commissioning, optimization)
- monitored (diagnostics)
- controlled (master control via the STARTER commissioning tool for test purposes).

A USB cable (3 m) and the STARTER commissioning tool ¹⁾ are included as scope of delivery on a DVD.

Selection and ordering data

	Order No.
PC Inverter Connection Kit -2 for CU230P-2 Control Units	new 6SL3255-0AA00-2CA0
Including USB cable (3 m) and STARTER commissioning tool ¹⁾ on DVD	

Supplementary system components PC Inverter Connection Kit

Overview



Example: PC Connection Kit for CU240 Control Units

For controlling and commissioning an inverter directly from a PC, if the STARTER commissioning tool has been installed on the PC. With these, the inverter can be

- parameterized (commissioning, optimization)
- monitored (diagnostics)
- controlled (master control via the STARTER commissioning tool for test purposes).

This is an isolated RS232 adapter board for a reliable point-to-point connection to a PC with a serial RS232 interface. A USB/RS232 adapter can be used as an alternative (e.g. type 12.02.1086R supplied by Roline).

The scope of delivery includes a 9-pin Sub-D connector, an RS232 standard cable (3 m) and the STARTER commissioning tool ¹⁾ on DVD.

Selection and ordering data

	Order No.
PC Inverter Connection Kit	6SL3255-0AA00-2AA1
Including a 9-pin Sub-D connector, an RS232 standard cable (3 m), and the STARTER commissioning tool ¹⁾ on DVD	

¹⁾ The STARTER commissioning tool is also available in the Internet under <http://support.automation.siemens.com/WW/view/en/10804985/133100>

Standard inverters 0.37 kW to 250 kW (0.5 hp to 400 hp)

Supplementary system components
Brake Relay

Overview



The Brake Relay allows the Power Module to be connected to an electromechanical motor brake, thereby allowing the motor brake to be driven directly by the Control Unit.

Selection and ordering data

	Order No.
Brake Relay Including cable harness for connection to the Power Module	6SL3252-0BB00-0AA0

Integration

The Brake Relay has the following interfaces:

- A switch contact (NO contact) to control the motor brake solenoid
- A connection for the cable harness (CTRL) for connection to the Power Module

The Brake Relay can be installed on the shield bonding plate near the power terminals of the Power Module.

The supplied Brake Relay includes the cable harness for connection with the Power Module.

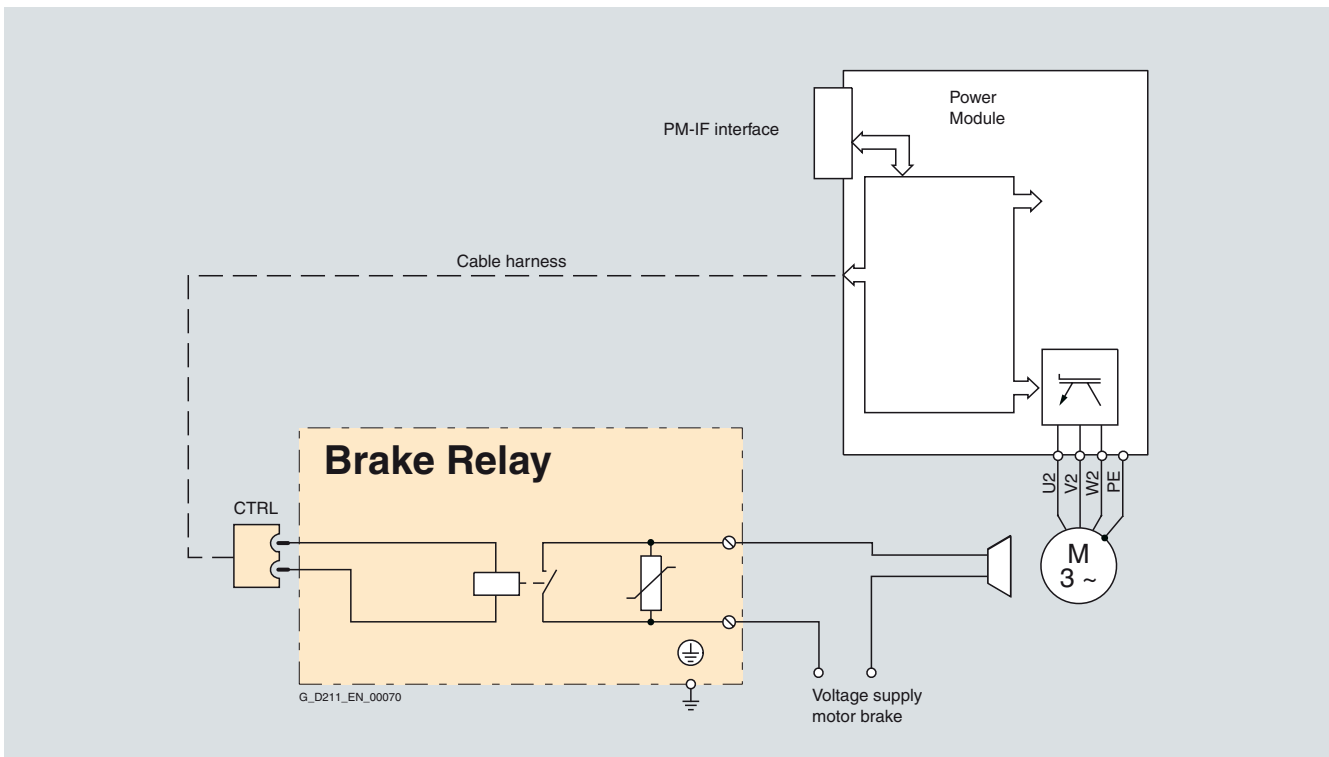

Connection example of a Brake Relay

Technical specifications

	Brake Relay
Max. switching capability of the NO contact	440 V AC / 3.5 A 30 V DC / 12 A
Max. conductor cross-section	2.5 mm ²
Degree of protection	IP20
Dimensions	
• Width	68 mm
• Height	63 mm
• Depth	33 mm
Weight, approx.	0.17 kg

SINAMICS G120

Standard inverters 0.37 kW to 250 kW (0.5 hp to 400 hp)

Supplementary system components Safe Brake Relay

Overview



The Safe Brake Relay allows the Power Module to be safely connected to an electromechanical motor brake, allowing the brake to be directly and safely controlled by the Control Unit in accordance with EN 954-1 Safety Category 3 and IEC 61508 SIL 2.

Selection and ordering data

	Order No.
Safe Brake Relay	6SL3252-0BB01-0AA0
Including cable harness for connection to the Power Module	

Integration

The Safe Brake Relay has the following interfaces:

- A two-channel transistor output stage to control the motor brake solenoid
- A connection for a 24 V DC power supply
- A connection for the cable harness (CTRL) for connection to the Power Module

The Safe Brake Relay can be mounted on the shield bonding plate near the power terminals of the Power Module.

The supplied Safe Brake Relay includes the cable harness for connection with the Power Module.

The 24 V DC solenoid of the motor brake is directly connected to the Safe Brake Relay. External surge suppressors are not required.

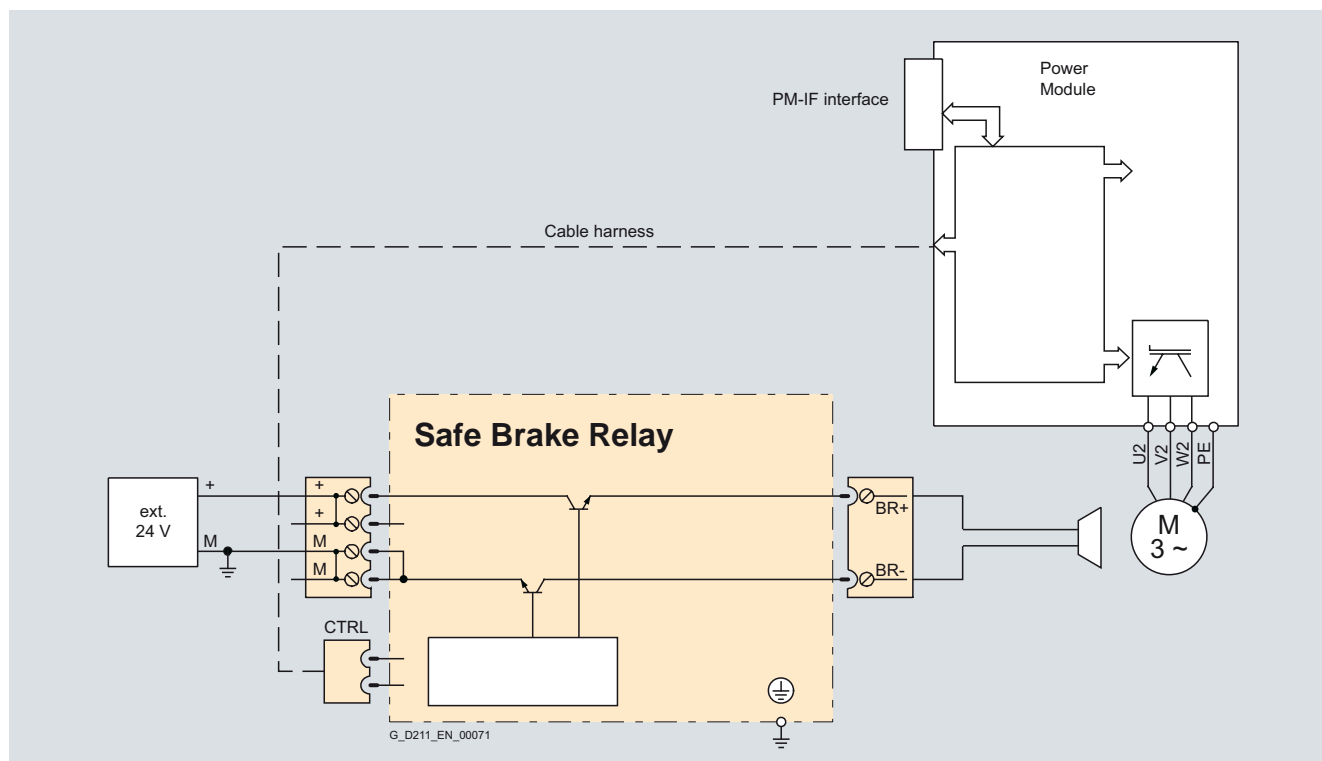

Connection example of a Safe Brake Relay

Technical specifications

	Safe Brake Relay
Supply voltage	20.4 ... 28.8 V DC Recommended rated value of the 26 V DC supply voltage (to equalize and compensate for the voltage drop along the feeder cable to the 24 V DC solenoid of the motor brake)
Max. current requirement of motor brake	2 A
Current requirement at 24 V DC, max.	0.005 A + the current requirement of motor brake

	Safe Brake Relay
Max. conductor cross-section	2.5 mm ²
Degree of protection	IP20
Dimensions	
• Width	68 mm
• Height	63 mm
• Depth	33 mm
Weight, approx.	0.17 kg

Standard inverters 0.37 kW to 250 kW (0.5 hp to 400 hp)

Supplementary system components
Adapter for mounting on DIN rails

Overview

The adapter for DIN rail mounting can be used to mount inverters, frame sizes FSA and FSB on DIN mounting rails (2 units with a center-to-center distance of 100 mm).

Furthermore, the motor cable shield connection and other cable shields required for mounting inverters on DIN rails comply with the same standards for emissions and conducted emissions as if the inverter were directly installed in a control cabinet.

The adapter for inverter frame size FSA can be used to mount converters singly or with matching line filter.

The adapter for inverter frame size FSB can be used to mount inverters with or without an integrated line filter.

Selection and ordering data

Adapter for mounting on DIN rails	Order No.
• for Power Module frame size FSA	6SL3262-1BA00-0BA0
• for Power Module frame size FSB	6SL3262-1BB00-0BA0

Supplementary system components
Shield Connection Kit

Overview

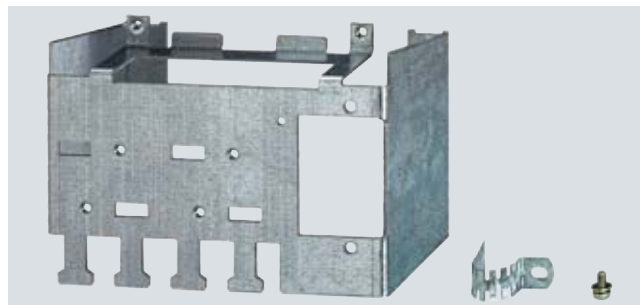

Example of Shield Connection Kit for Power Module frame size FSB

The Shield Connection Kit

- makes it easier to connect the shields of supply and control cables
- provides mechanical strain relief
- ensures optimum EMC performance
- is used to attach the Brake Relay and Safe Brake Relay

The Shield Connection Kit includes

- a shield bonding plate for the required Power Module
- a shield bonding plate for a CU240 Control Unit
- connection elements and clamps for mounting
- mounting device for Brake Relay or Safe Brake Relay – frame sizes FSB to FSF

Selection and ordering data

Shield Connection Kit	Order No.
• for PM240/PM250 Power Modules	
- Frame size FSA	6SL3262-1AA00-0BA0
- Frame size FSB	6SL3262-1AB00-0DA0
- Frame size FSC	6SL3262-1AC00-0DA0
- Frame sizes FSD and FSE	6SL3262-1AD00-0DA0
- Frame size FSF	6SL3262-1AF00-0DA0
• for PM260 Power Modules	
- Frame size FSD	6SL3262-1FD00-0CA0
- Frame size FSF	6SL3262-1FF00-0CA0

SINAMICS G120

Standard inverters 0.37 kW to 250 kW (0.5 hp to 400 hp)

Supplementary system components Shield Connection Kit 1 for CU230P-2

Overview

The Shield Connection Kit 1 for CU230P-2 Control Units offers for all signal and communication cables

- Optimum shield connection
- Strain relief

It contains the following:

- A matching shield bonding plate
- All of the necessary connecting and retaining elements for mounting

The Shield Connection Kit 1 is suitable for the following SINAMICS G120 Control Units:

- CU230P-2 HVAC
- CU230P-2 DP
- CU230P-2 CAN

Selection and ordering data

	Order No.
Shield Connection Kit 1 for CU230P-2 Control Units	new 6SL3264-1EA00-0FA0

Supplementary system components Shield Connection Kit for CU240S Control Units

Overview

The Shield Connection Kit for CU240S Control Units offers for all signal and communication cables

- Optimum shield connection
- Strain relief

It contains the following:

- A matching shield bonding plate
- All of the necessary connecting and retaining elements for mounting

The Shield Connection Kit is suitable for the following SINAMICS G120 Control Units:

- CU240S
- CU240S DP
- CU240S DP-F
- CU240S PN
- CU240S PN-F

Selection and ordering data

	Order No.
Shield Connection Kit For CU240S Control Units	new 6SL3264-1EA00-0EA0

Standard inverters 0.37 kW to 250 kW (0.5 hp to 400 hp)

Spare parts
CU240 Spare Parts Kit

Overview

The CU240 Spare Parts Kit includes:

- A replacement cover to cover the terminals
- A matching shield bar for the CU240E Control Unit, incl. screws
- A replacement connector for the CU240S Control Unit
- A protective element for the MMC card slot
- Screws to attach the shield bonding plate of the CU240S Control Unit

The CU240 Spare Parts Kit is suitable for the following SINAMICS G120 Control Units:

- CU240E
- CU240S
- CU240S DP
- CU240S DP-F
- CU240S PN
- CU240S PN-F

Selection and ordering data

	Order No.
CU240 Spare Parts Kit For CU240E and CU240S Control Units	new 6SL3200-0SK00-0AA0

Spare parts
Spare door for PM240 frame size FSGX

Overview

Complete replacement door for the PM240 Power Module frame size FSGX

Selection and ordering data

	Order No.
Replacement door for PM240 Power Module frame size FSGX	new 6SL3200-0SM10-0AA0

SINAMICS G120

Standard inverters 0.37 kW to 250 kW (0.5 hp to 400 hp)

Spare parts

Terminal Cover Kit for frame sizes FSD and FSE

Overview

The Terminal Cover Kit includes a replacement cover for the connecting terminals.

The Terminal Cover Kit is suitable for the following SINAMICS G120 Power Modules:

- PM240 frame sizes FSD and FSE
- PM250 frame sizes FSD and FSE

Selection and ordering data

	Order No.
Terminal Cover Kit for frame sizes FSD and FSE	new 6SL3200-0SM11-0AA0

Spare parts

Terminal Cover Kit for frame size FSF

Overview

The Terminal Cover Kit includes a replacement cover for the connecting terminals.

The Terminal Cover Kit is suitable for the following SINAMICS G120 Power Modules:

- PM240 frame size FSF
- PM250 frame size FSF
- PM260 frame size FSF

Selection and ordering data

	Order No.
Terminal Cover Kit for frame size FSF	new 6SL3200-0SM12-0AA0

SINAMICS G120

Standard inverters 0.37 kW to 250 kW (0.5 hp to 400 hp)

Spare parts
Spare connector

Overview

Replacement connector for the input and output sides.

The replacement connector is suitable for the following SINAMICS G120 PM260 Power Modules frame size FSD.

Selection and ordering data

	Order No.
Replacement connector for PM260 Power Modules frame size FSD	new 6SL3200-0ST04-0AA1

SINAMICS G120

Standard inverters 0.37 kW to 250 kW (0.5 hp to 400 hp)

Spare parts Replacement fan

Overview

The Power Module fans are designed for extra long service life. Replacement fans can be ordered for special applications.

Selection and ordering data

Rated power		SINAMICS G120 PM240 Power Module		Replacement fan	
kW	hp	Type 6SL3224-...	Frame size and number of fans	Order No.	
380 ... 480 V 3 AC					
0.37	0.50	OBE13-7UA0	FSA, 1 fan	6SL3200-0SF01-0AA0 (includes 1 replacement fan)	
0.55	0.75	OBE15-5UA0			
0.75	1.0	OBE17-5UA0			
1.1	1.5	OBE21-1UA0			
1.5	2	OBE21-5UA0			
2.2	3	OBE22-2 . A0	FSB, 2 fans ¹⁾		
3.0	4	OBE23-0 . A0			
4.0	5	OBE24-0 . A0			
7.5	10	OBE25-5 . A0	FSC, 2 fans ¹⁾	6SL3200-0SF03-0AA0 (includes 1 replacement fan)	
11.0	15	OBE27-5 . A0			
15.0	20	OBE31-1 . A0			
18.5	25	OBE31-5 . A0	FSD, 2 fans	6SL3200-0SF04-0AA0 (includes 2 replacement fans)	
22	30	OBE31-8 . A0			
30	40	OBE32-2 . A0		6SL3200-0SF05-0AA0 (includes 2 replacement fans)	
37	50	OBE33-0 . A0	FSE, 2 fans	6SL3200-0SF04-0AA0 (includes 2 replacement fans)	
45	60	OBE33-7 . A0			
55	75	OBE34-5 . A0	FSF, 2 fans	6SL3200-0SF06-0AA0 (includes 2 replacement fans)	
75	100	OBE35-5 . A0			
90	125	OBE37-5 . A0		6SL3200-0SF07-0AA0 (includes 2 replacement fans)	
110	150	OBE38-8UA0		6SL3200-0SF08-0AA0 (includes 2 replacement fans)	
132	200	OBE41-1UA0			
160	250	OXE41-3UA0	FSGX, 2 fans	6SL3362-0AG00-0AA1 (includes 2 replacement fans)	
200	300	OXE41-6UA0			
250	400	OXE42-0UA0			

Rated power		SINAMICS G120 PM250 Power Module		Replacement fan	
kW	hp	Type 6SL3225-...	Frame size and number of fans	Order No.	
380 ... 480 V 3 AC					
7.5	10	OBE25-5AA0	FSC, 2 fans ¹⁾	6SL3200-0SF03-0AA0 (includes 1 replacement fan)	
11.0	15	OBE27-5AA0			
15.0	20	OBE31-1AA0			
18.5	25	OBE31-5 . A0	FSD, 2 fans	6SL3200-0SF04-0AA0 (includes 2 replacement fans)	
22	30	OBE31-8 . A0			
30	40	OBE32-2 . A0		6SL3200-0SF05-0AA0 (includes 2 replacement fans)	
37	50	OBE33-0 . A0	FSE, 2 fans	6SL3200-0SF04-0AA0 (includes 2 replacement fans)	
45	60	OBE33-7 . A0			
55	75	OBE34-5 . A0	FSF, 2 fans	6SL3200-0SF06-0AA0 (includes 2 replacement fans)	
75	100	OBE35-5 . A0			
90	125	OBE37-5 . A0		6SL3200-0SF08-0AA0 (includes 2 replacement fans)	

Rated power		SINAMICS G120 PM260 Power Module		Replacement fan	
kW	hp	Type 6SL3225-...	Frame size and number of fans	Order No.	
660 ... 690 V 3 AC					
11.0	15	OBH27-5 . A1	FSD, 2 fans	6SL3200-0SF11-0AA0 (includes 2 replacement fans)	
15.0	20	OBH31-1 . A1			
18.5	25	OBH31-5 . A1			
30	40	OBH32-2 . A1	FSF, 2 fans	6SL3200-0SF07-0AA0 (includes 2 replacement fans)	
37	50	OBH33-0 . A1			
55	75	OBH33-7 . A1			

¹⁾ Recommended: Even if only one fan on the Power Module is defective, it is advisable to replace both. In this case, the order quantity must be doubled.