

VACON[®] 20 X
AC DRIVES

**INSTALLATION, TECHNICAL AND MAINTENANCE
MANUAL**

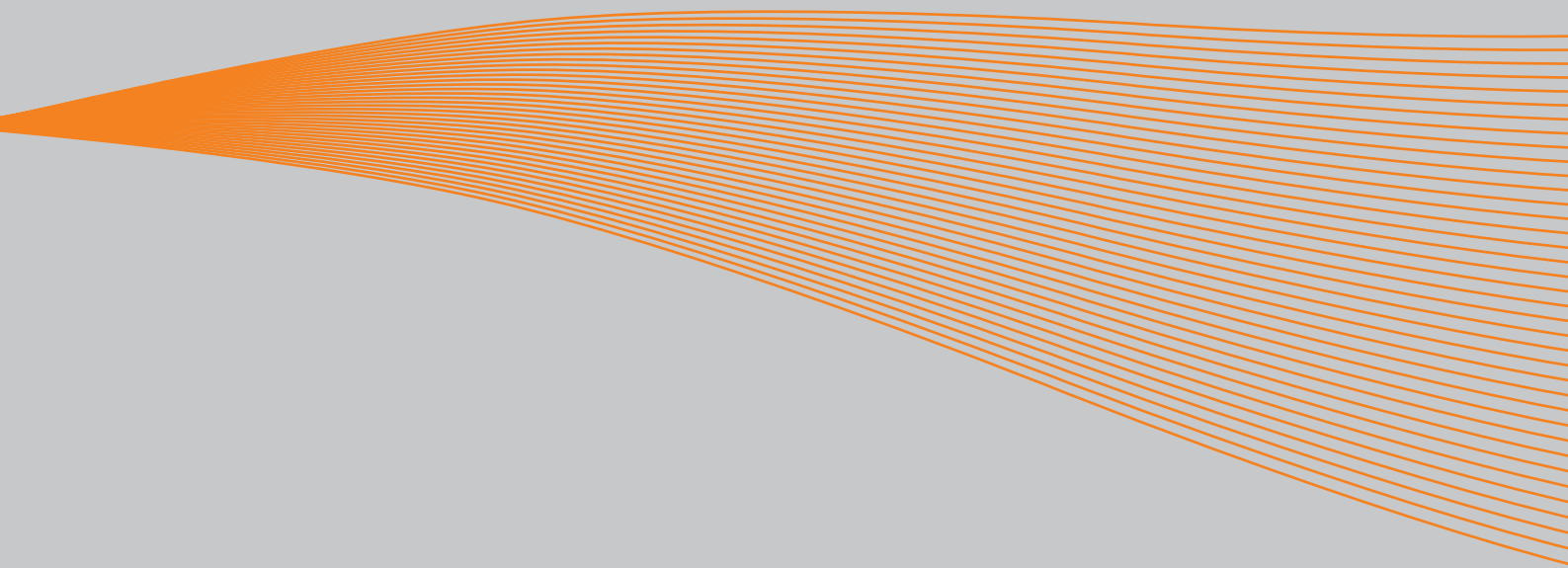

VACON[®]
DRIVEN BY DRIVES

INDEX

Document code (Original Instructions): DPD00992F

Order code: DOC-INS06663+DLUK

Rev. F

Revision release date: 4.2.15

| | |
|--|-----------|
| 1. Safety | 4 |
| 1.1 Signs | 4 |
| 1.2 Units | 4 |
| 1.3 Danger | 5 |
| 1.4 Warnings | 6 |
| 1.5 Earthing and earth fault protection | 7 |
| 1.6 Insulation system | 9 |
| 1.7 Compatibility with RCDs..... | 10 |
| 1.8 Extended temperature range..... | 11 |
| 1.9 Declaration of conformity | 12 |
| 2. Receipt of delivery..... | 16 |
| 2.1 Type designation code..... | 17 |
| 2.2 Order codes | 18 |
| 2.3 Unpacking and lifting the AC drive | 19 |
| 2.4 Accessories | 19 |
| 2.4.1 'Product modified' sticker..... | 20 |
| 2.4.2 Disposal..... | 20 |
| 3. Mounting..... | 22 |
| 3.1 Dimensions..... | 22 |
| 3.1.1 Frame MU2 and MU3 | 22 |
| 3.2 Cooling..... | 24 |
| 4. Power cabling..... | 26 |
| 4.1 Circuit breaker | 28 |
| 4.2 UL standards on cabling | 28 |
| 4.3 Description of the terminals | 29 |
| 4.3.1 MU2 three-phase version power connections..... | 29 |
| 4.3.2 MU2 single-phase version power connections..... | 30 |
| 4.3.3 MU3 power connections..... | 31 |
| 4.4 Cable dimensioning and selection | 32 |
| 4.5 Brake resistor cables..... | 34 |
| 4.6 Control cables | 34 |
| 4.7 Cable installation | 35 |
| 4.8 Wiring way | 41 |
| 5. Control unit | 42 |
| 5.1 Opening the drives | 42 |
| 5.2 Control units MU2 and MU3 | 44 |
| 5.3 Control unit cabling..... | 47 |
| 5.3.1 Control cable sizing..... | 47 |
| 5.3.2 Standard I/O terminals..... | 48 |
| 5.3.3 Relay terminals | 49 |
| 5.3.4 Safe Torque off (STO) terminals | 49 |
| 5.3.5 Description of additional echo connectors | 50 |
| 5.3.6 Led handling..... | 52 |
| 5.3.7 Selection of terminal functions with dip switches..... | 53 |
| 5.4 Fieldbus connection | 54 |
| 5.4.1 Modbus RTU protocol..... | 55 |

| | | |
|-----------|---|------------|
| 5.4.2 | Preparation for use through RS485..... | 56 |
| 6. | Commissioning..... | 58 |
| 6.1 | Commissioning of the drive..... | 59 |
| 6.2 | Changing EMC protection class..... | 60 |
| 6.2.1 | Changing EMC protection class - MU2 three-phase version..... | 60 |
| 6.2.2 | Changing EMC protection class - MU2 single-phase version..... | 62 |
| 6.2.3 | Changing EMC protection class - MU3..... | 63 |
| 6.3 | Running the motor..... | 64 |
| 6.3.1 | Cable and motor insulation checks..... | 64 |
| 6.4 | Maintenance..... | 65 |
| 7. | Technical data..... | 66 |
| 7.1 | AC drive power ratings..... | 66 |
| 7.1.1 | Mains voltage 3AC 208-240V..... | 66 |
| 7.1.2 | Mains voltage 1AC 208-240V..... | 66 |
| 7.1.3 | Mains voltage 3AC 380-480V..... | 67 |
| 7.1.4 | Definitions of overloadability..... | 67 |
| 7.2 | Brake resistor ratings..... | 68 |
| 7.3 | VACON® 20 X - technical data..... | 69 |
| 7.3.1 | Technical information on control connections..... | 72 |
| 8. | Options..... | 74 |
| 8.1 | Vacon keypad with seven-segment display..... | 74 |
| 8.1.1 | Mounting onto the drive..... | 74 |
| 8.1.2 | Text Keypad - buttons..... | 77 |
| 8.2 | Text keypad..... | 78 |
| 8.3 | Menu structure..... | 78 |
| 8.4 | Using the keypad..... | 79 |
| 8.4.1 | Main menu..... | 79 |
| 8.4.2 | Resetting fault..... | 80 |
| 8.4.3 | Local/Remote control button..... | 80 |
| 8.4.4 | Reference menu..... | 80 |
| 8.4.5 | Monitoring menu..... | 81 |
| 8.4.6 | Parameter menu..... | 82 |
| 8.4.7 | System/Fault menu..... | 83 |
| 8.4.8 | Fault tracing..... | 85 |
| 8.5 | Option boards..... | 89 |
| 8.5.1 | Option board installation..... | 90 |
| 8.6 | Mains switch..... | 94 |
| 8.6.1 | Installation..... | 95 |
| 8.7 | Simple operator panel..... | 98 |
| 8.7.1 | Installation..... | 99 |
| 9. | Safe Torque Off..... | 104 |
| 9.1 | General description..... | 104 |
| 9.2 | Warnings..... | 104 |
| 9.3 | Standards..... | 105 |
| 9.4 | The principle of STO..... | 106 |
| 9.4.1 | Technical details..... | 107 |
| 9.5 | Connections..... | 108 |
| 9.5.1 | Safety Capability Cat.4 / PL e / SIL 3..... | 109 |
| 9.5.2 | Safety Capability Cat. 3 / PL e / SIL 3..... | 111 |
| 9.5.3 | Safety Capability Cat. 2 / PL d / SIL 2..... | 111 |
| 9.5.4 | Safety Capability Cat.1 / PL c / SIL 1..... | 112 |
| 9.6 | Commissioning..... | 113 |

| | | |
|-------|-----------------------------------|-----|
| 9.6.1 | General wiring instructions | 113 |
| 9.6.2 | Checklist for commissioning | 113 |
| 9.7 | Parameters and fault tracing..... | 114 |
| 9.8 | Maintenance and diagnostics | 115 |

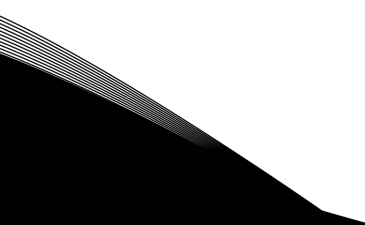

1. SAFETY

This manual contains clearly marked warning information which is intended for your personal safety and to avoid any unintentional damage to the product or connected appliances.

Please read the warning information carefully.

VACON® 20 X is a drive designed to control asynchronous AC motors and permanent magnet motors. The product is intended to be installed in a restricted access location and for a general purpose use.

Only Vacon authorized, trained and qualified personnel are allowed to install, operate and maintain the drive.

1.1 SIGNS

The cautions and warnings are marked as follows:



| | |
|---|-----------------------------|
|  | = DANGEROUS VOLTAGE! |
|  | = HOT SURFACE! |
|  | = WARNING or CAUTION |

Table 1. Warning signs.

1.2 UNITS

The dimensions used in this manual conform to International Metric System units, otherwise known as SI (Système International d'Unités) units. For the purpose of the equipment's UL certification, some of these dimensions are accompanied by their imperial equivalents.

| Physical dimension | SI value | US value | Conversion factor | US designation |
|--------------------|---------------------|--------------|--------------------|-----------------------|
| length | 1 mm | 0.0394 inch | 25.4 | inch |
| Weight | 1 kg | 2.205 lb | 0.4536 | pound |
| Speed | 1 min ⁻¹ | 1 rpm | 1 | revolution per minute |
| Temperature | 1 °C (T1) | 33.8 °F (T2) | T2 = T1 x 9/5 + 32 | Fahrenheit |
| Torque | 1 Nm | 8.851 lbf in | 0.113 | pound-force inches |
| Power | 1 kW | 1.341 HP | 0.7457 | horsepower |

Table 2. Unit conversion table.

1.3 DANGER



The **components of the power unit of VACON[®] 20 X drives are live** when the drive is connected to the mains potential. Coming into contact with this voltage is **extremely dangerous** and may cause death or severe injury.



The **motor terminals (U, V, W) are live** when VACON[®] 20 X Drive is connected to the mains, even if the motor is not running.



After disconnecting the AC drive from the mains, **wait** until the indicators on the keypad go out (if no keypad is attached, see the indicators on the cover). Wait an additional 30 seconds before starting any work on the connections of VACON[®] 20 X Drive. After expiration of this time, use measuring equipment to absolutely ensure that no voltage is present. **Always ensure absence of voltage before starting any electrical work!**



The control I/O-terminals are isolated from the mains potential. However, the **relay outputs and other I/O-terminals may have a dangerous control voltage** present even when VACON[®] 20 X Drive is disconnected from the mains.



During a coast stop (see the Application Manual), the motor is still generating voltage to the drive. Therefore, do not touch the components of the AC drive before the motor has completely stopped. Wait until the indicators on the keypad go out (if no keypad is attached, see the indicators on the cover). Wait an additional 30 seconds before starting any work on the drive.

1.4 WARNINGS



VACON® 20 X AC drive is meant for **fixed installations only**.



Only DVC A circuits (Decisive Voltage Class A, according to IEC 61800-5-1) are allowed to be connected to the control unit. This advice aims to protect both the drive and the client-application. Vacon is not responsible for direct or consequential damages resulting from unsafe connections of external circuits to the drive. See paragraph 1.6 for more details.



Do not perform any measurements when the AC drive is connected to the mains.



The **touch current** of VACON® 20 X drives exceeds 3.5mA AC. According to standard EN61800-5-1, **a reinforced protective ground connection** must be ensured. See paragraph 1.5.



If the AC drive is used as a part of a machine, the **machine manufacturer is responsible** for providing the machine with a **supply disconnecting device** (EN 60204-1). See paragraph 4.1



Only **spare parts** supplied by Vacon can be used.



At power-up, power brake or fault reset, **the motor will start immediately** if the start signal is active, unless the pulse control for Start/Stop logic has been selected. Furthermore, the I/O functionalities (including start inputs) may change if parameters, applications or software are changed. Disconnect, therefore, the motor if an unexpected start can cause danger. This is valid only if STO inputs are energized. For prevention on unexpected restart, use appropriate safety relay connected to the STO inputs.



The **motor starts automatically** after automatic fault reset if the autoreset function is activated. See the Application Manual for more detailed information. This is valid only if STO inputs are energized. For prevention on unexpected restart, use appropriate safety relay connected to the STO inputs.



Before performing any measurement on the motor or the motor cable, disconnect the motor cable from the AC drive.



Do not perform any voltage withstand test on any part of VACON® 20 X. The tests shall be performed according to a specific procedure. Ignoring this procedure may damage the product.



Do not touch the components on the circuit boards. Static voltage discharge may damage the components.



Check that the **EMC level** of the AC drive corresponds to the requirements of your supply network.



In a domestic environment, this product may cause radio interference, in which case supplementary mitigation measures may be required.

1.5 EARTHING AND EARTH FAULT PROTECTION



CAUTION!

The VACON® 20 X AC drive must always be earthed with an earthing conductor connected to the earthing terminal marked with \perp .

Since the touch current exceeds 3.5 mA AC (for the three-phase version), according to EN61800-5-1, the drive shall have a fixed connection and provision of an additional terminal for a second protective earthing conductor of the same cross-sectional area as the original protective earthing conductor.

Three screws (for the three-phase version) are provided for: the ORIGINAL protective earthing conductor, the SECOND protective conductor and the MOTOR protective conductor (the customer can choose the screw for each one). See Figure 1 for the location of the three screws in the two possible options available.

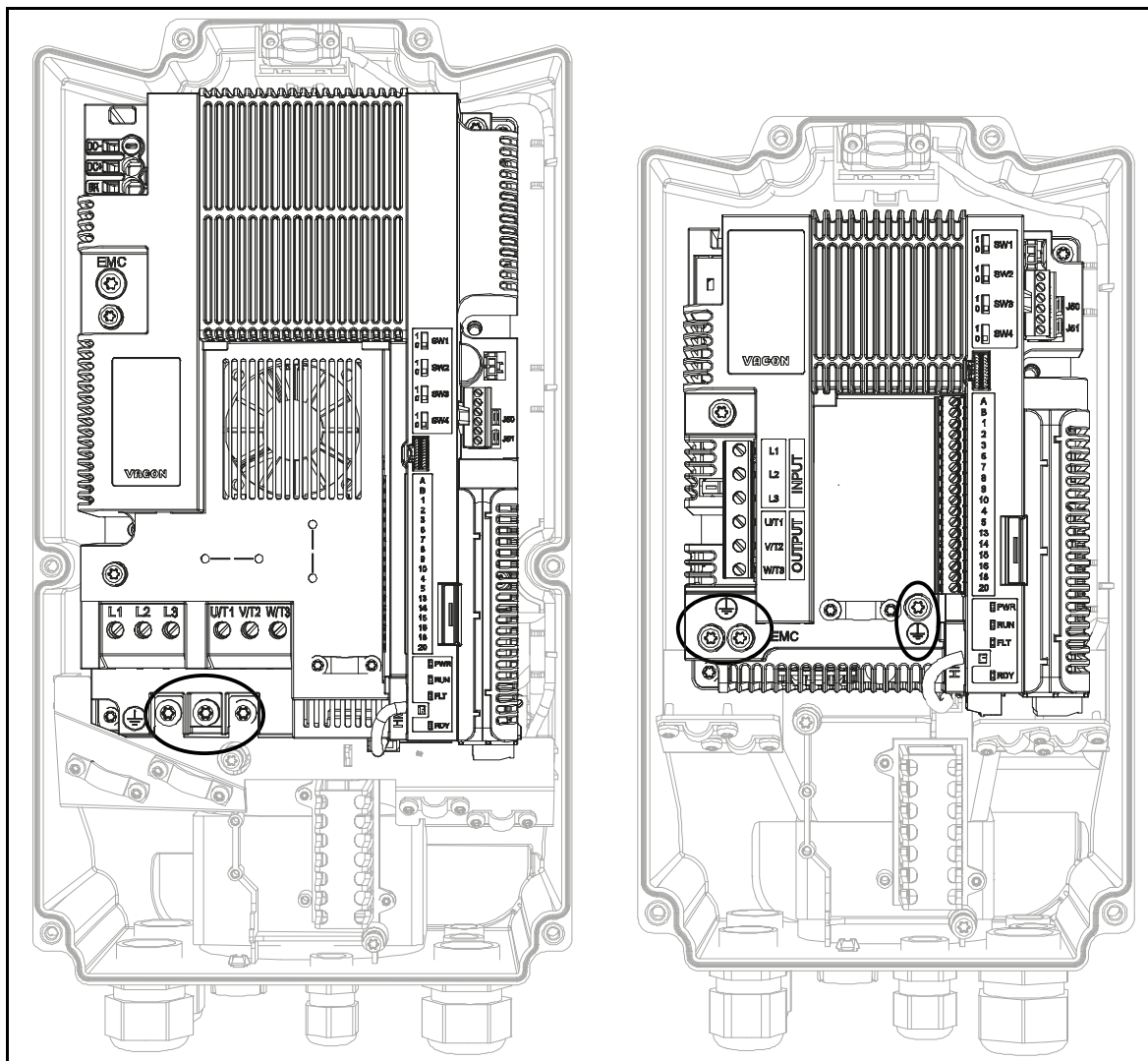

Figure 1. Protective earthing connections MU2 and MU3, three-phase version.

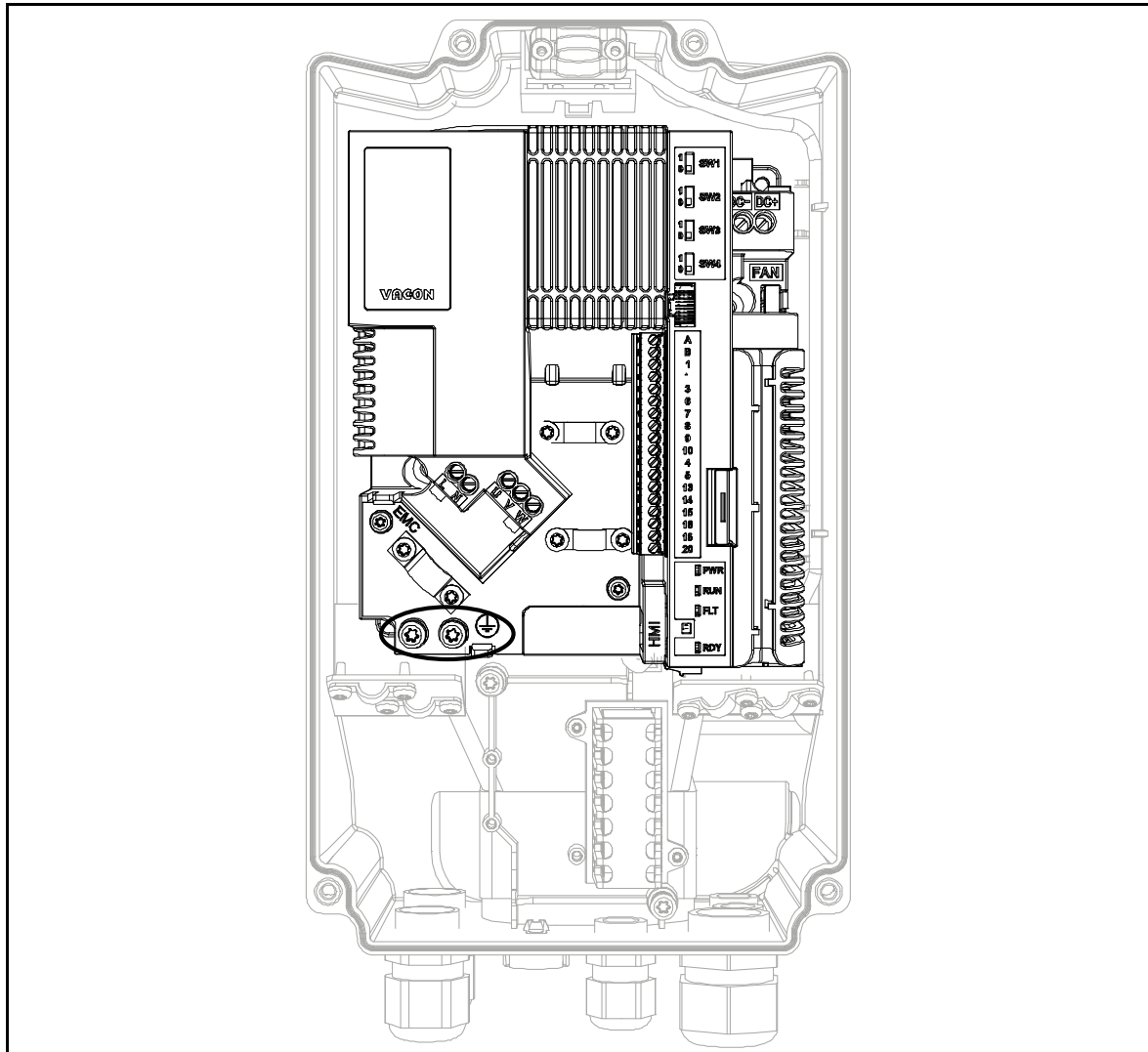

Figure 2. Protective earthing connections MU2, single-phase version.

In VACON[®] 20 X, the phase conductor and the corresponding protective earthing conductor can be of the same cross-sectional area, provided they are made of the same metal (because the cross-sectional area of the phase conductor is less than 16 mm²).

The cross-sectional area of every protective earthing conductor which does not form a part of the supply cable or cable enclosure shall, in any case, be not less than:

- 2.5 mm² if mechanical protection is provided or
- 4 mm² if mechanical protection is not provided. For cord-connected equipment, provisions shall be made so that the protective earthing conductor in the cord shall, in the case of failure of the strain-relief mechanism, be the last conductor to be interrupted.

However, always follow the local regulations for the minimum size of the protective earthing conductor.

NOTE: Due to the high capacitive currents present in the AC drive, fault current protective switches may not function properly.

1.6 INSULATION SYSTEM



Please, consider carefully the insulation system depicted in Figure 2, before connecting any circuit to the unit.



The control unit of VACON® 20 X fulfils the insulation requirements of the standard IEC 61800-5-1 regarding DVC A circuits and also the strongest insulation requirements of IEC 60950-1 regarding SELV circuits.

A distinction has to be made for the following three groups of terminals, according to the insulation system of VACON® 20 X:

- Mains and motor connections (L1, L2, L3, U, V, W) or (L, N, U, V, W)
- Relays (R01, R02)^(**)
- Control terminals (I/Os, RS485, STO)

The Control terminals (I/Os, RS485, STO) are isolated from the Mains (the insulation is reinforced, according to IEC 61800-5-1) and **the GND terminals are referred to PE.**

This is important when you need to connect other circuits to the drive and test the complete assembly. Should you have any doubts or questions, please contact your local Vacon distributor.

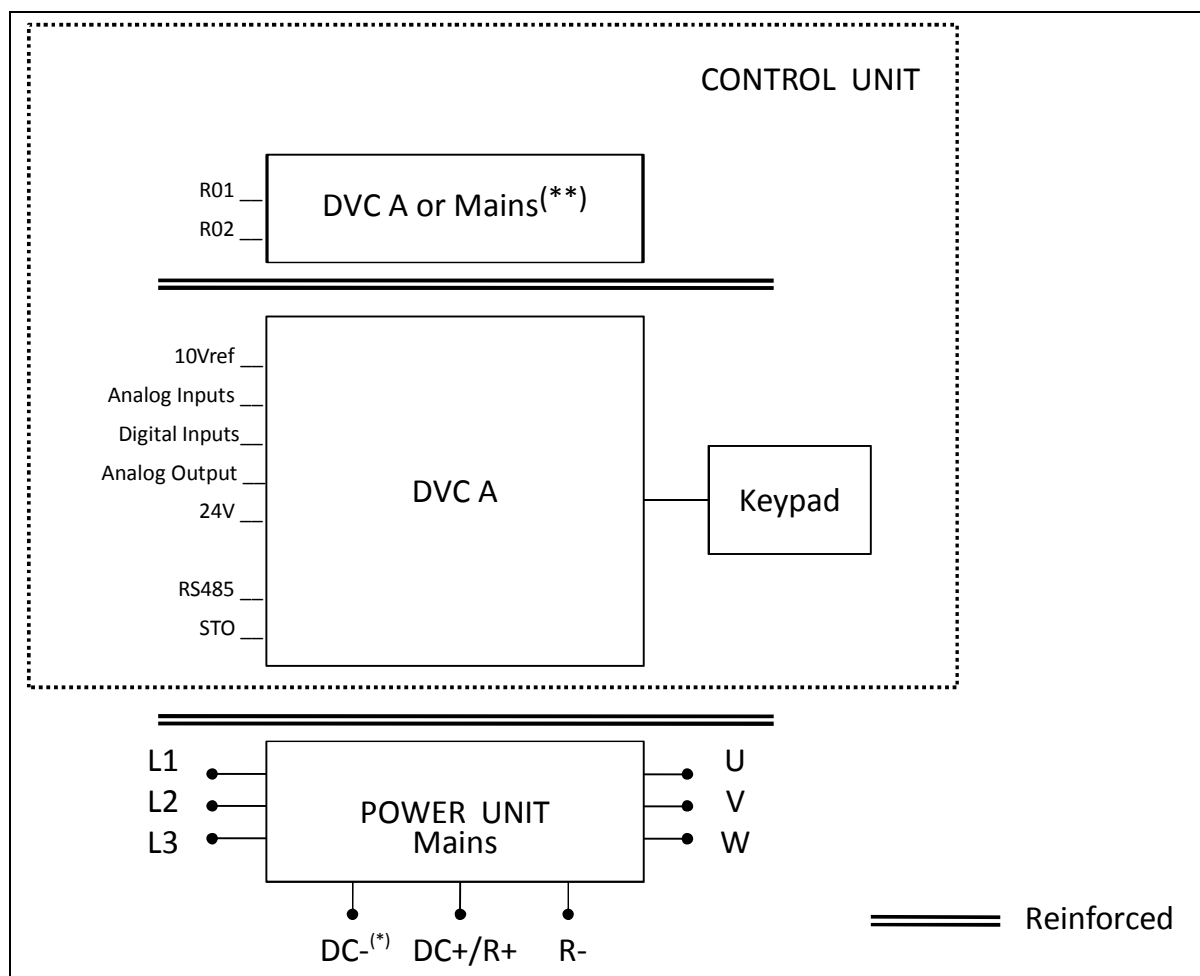

Figure 3. Insulation system (three-phase version).

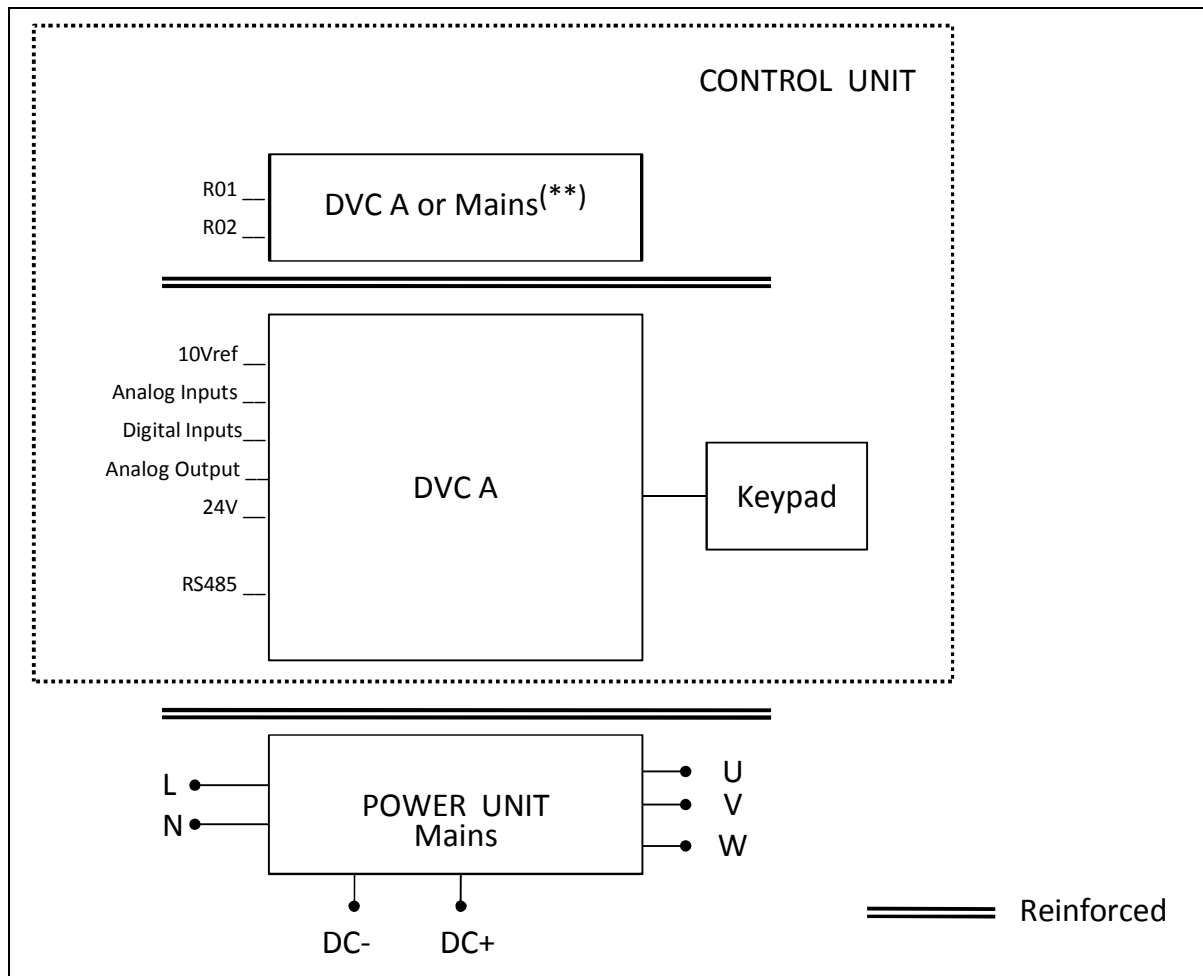

Figure 4. Insulation system (single-phase version).

(*) Only for MU3.



(**) The relays may be used also with DVC A circuits. This is possible only if both relays are used for DVC A circuitry: **to mix Mains and DVC A is not allowed.**



By performing the cabling, a suitable clearance has to be guaranteed between DVC A circuits and Mains (reinforced insulation is required, according to IEC 61800-5-1).



1.7 COMPATIBILITY WITH RCDS



This product can cause a d.c. current in the protective earthing conductor. Where a residual current-operated protective (RCD) or monitoring (RCM) device is used for protection in case of direct or indirect contact, only an RCD or RCM of Type B is allowed on the supply side of this product.

1.8 EXTENDED TEMPERATURE RANGE

VACON® 20 X has **an integrated cooling system**, independent from the motor fan. Under maximum operating conditions, the ambient temperature cannot exceed **40 °C**. See Table 24 for the output rated current. Higher temperatures are allowed only with derating of the output current. With derating the unit can **operate up to 50°C**.

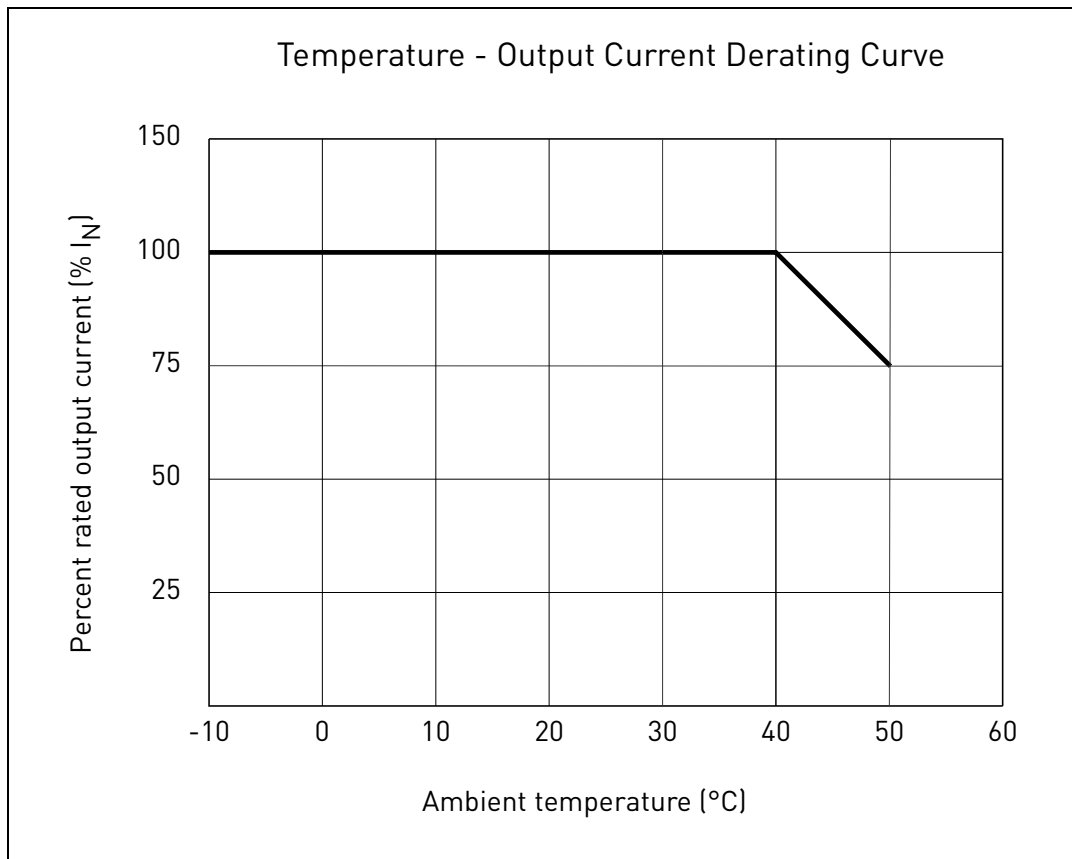

Figure 5. Temperature-output current derating curve.

The AC drive is cooled down by air-ventilation. Therefore, make sure that enough free space is left around the AC drive to ensure sufficient air circulation (see for more details the mounting instructions on chapter 3).

NOTE: Up to 1.5 kW (Voltage range 380-480V) and 0.75 kW (Voltage range 208-240V) the drive is not equipped with external cooling fan.

1.9 DECLARATION OF CONFORMITY



EC DECLARATION OF CONFORMITY

Manufacturer's name: Vacon Srl

Manufacturer's address: Via Roma, 2
I-39014 Postal (BZ), Italy

We hereby declare that the following product

Product name: Vacon 20 AC drive

Product Identification: VACON0020-3L-a-b-c ±d ±e and VACON0020-1L-a-b-c ±d ±e
a = 0001 – 0008; (Frame Size 2)
a = 0009 – 0016; (Frame Size 3)
b = 2, 4, 5; (Voltage Rating)
c = CP, X; (Enclosure option)
±d, ±e = Additional Codes

Product Safety Functions: Safe Torque Off (EN 61800-5-2:2007) and Emergency stop
(EN 60204-1:2006 + A1:2009 + AC:2010 in extracts) available only on VACON0020-3L-a-b-c ±d ±e

Complies with the following EU legislation: Low Voltage Directive (LVD) 2006/95/EC, Electromagnetic Compatibility (EMC) 2004/108/EC, EC Machinery Directive 2006/42/EC.

Notified body that carried out the EC type examination:

TÜV Rheinland Industrie Service GmbH,
Alboinstr. 56, 12103 Berlin / Germany

Certification Body for Machinery NB 0035, Certificate No. 01/205/5215/12 (applied to b = 4, 5)

The following standards and/or technical specifications referenced below were used:

EN 61800-5-2:2007
EN 61800-5-1:2007 (LV Directive compliance)
EN 61800-3:2004+A1:2012 (EMC Directive compliance)
EN ISO 13849-1:2008+AC:2009
EN 62061:2005+AC:2010

These products are intended for installation in machines. Operation is prohibited until it has been determined that the machines in which these products are to be installed, conforms to the above mentioned EC Directive(s).

Signature

Postal, 27.10.2014

Andrea Perin
Country Manager



Figure 6. Declaration of conformity.

TÜVRheinland®

**ZERTIFIKAT
CERTIFICATE**

EC Type-Examination Certificate

Reg.-No.: 01/205/5215/12

| | | | |
|--|--|--|---|
| Product tested | Safety function "Safe Torque Off (STO)" within Adjustable Frequency AC Drive | Certificate holder | Vacon S.R.L. Via Roma, 2 I-39014 Postal (BZ) Italy |
| Type designation | Vacon 20 AC Drive VACON0020-3L-a-b-c +d +e a = 0001-0008; (Frame Size 2), a = 0009-0016; (Frame Size 3), b = 4, 5; (Voltage Rating), c = CP, X; (Enclosure Option), +d, +e = Additional Codes | Manufacturer | see certificate holder |
| Codes and standards forming the basis of testing | EN 61800-5-2:2007 EN 61800-5-1:2007 EN 61800-3:2004 EN ISO 13849-1:2008 + AC:2009 | EN 62061:2005 + AC:2010 IEC 61508 Parts 1-7:2010 EN 60204-1:2006 + A1:2009 + AC:2010 (in extracts) | |
| Intended application | The safety function "Safe Torque Off" complies with the requirements of the relevant standards (PL e acc. to EN ISO 13849-1, SIL CL 3 acc. to EN 61800-5-2 / EN 62061 / IEC 61508) and can be used in applications up to PL e acc. to EN ISO 13849-1 and SIL 3 acc. to EN 62061 / IEC 61508. | | |
| Specific requirements | The instructions of the associated Installation and Operating Manual shall be considered. | | |
| It is confirmed that the product under test complies with the requirements for machines defined in Annex I of the EC Directive 2006/42/EC. | | | |
| This certificate is valid until 2017-04-27. | | | |

The test report-no.: 968/M 349.00/12 dated 2012-04-27 is an integral part of this certificate.

This certificate is valid only for products which are identical with the product tested at any change of the codes and standards forming the intended application.



Berlin, 2012-04-27

Certification Body for Machinery, NB 0035



Dipl.-Ing. Eberhard Frejno

TÜV Rheinland Industrie Service GmbH, Alboinistr. 56, 12103 Berlin / Germany
 Tel.: +49 30 7562-1557, Fax: +49 30 7562-1370, E-Mail: tura@de.tuv.com

Figure 7. STO certificate.

NOTE! You can download the English and French product manuals with applicable safety, warning and caution information from www.vacon.com/downloads.

REMARQUE Vous pouvez télécharger les versions anglaise et française des manuels produit contenant l'ensemble des informations de sécurité, avertissements et mises en garde applicables sur le site www.vacon.com/downloads.

2. RECEIPT OF DELIVERY

Check correctness of delivery by comparing your order data to the drive information found on the package label. If the delivery does not correspond to your order, contact your supplier immediately. See paragraph 2.4.

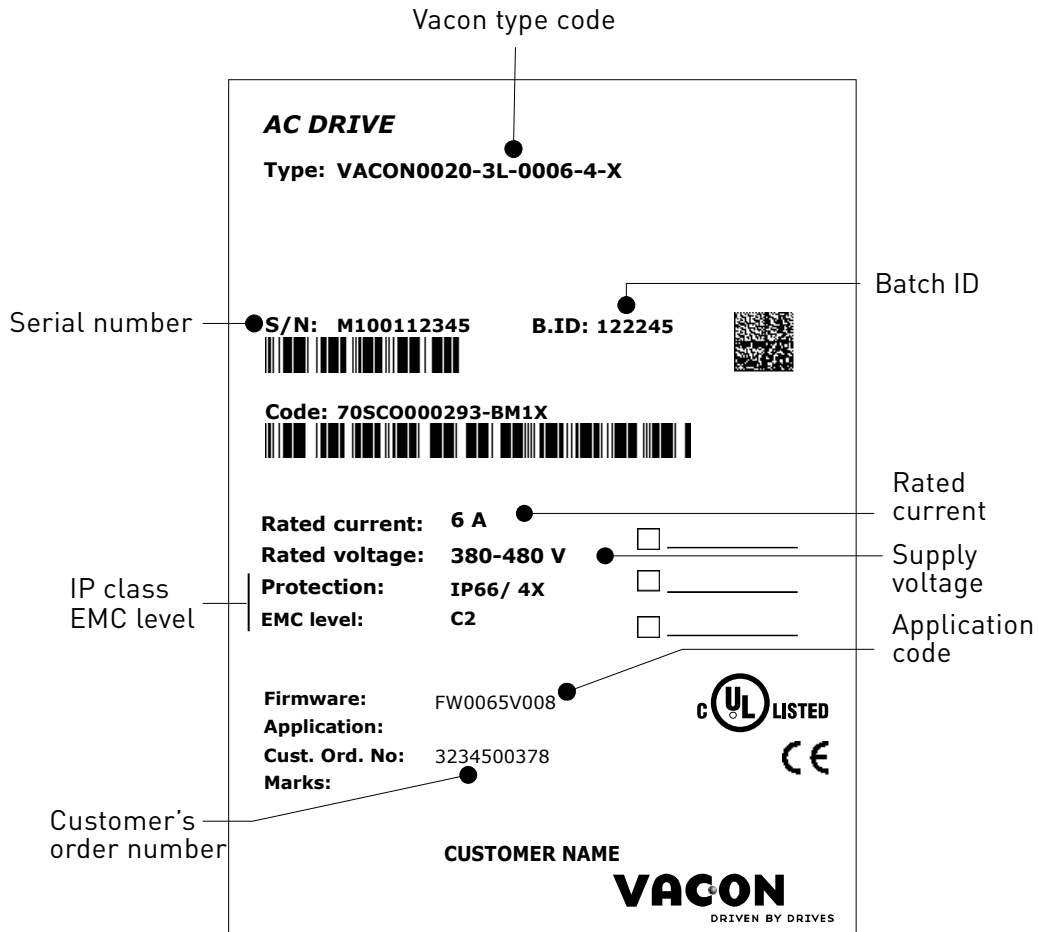

Figure 8. Vacon package label.

2.1 TYPE DESIGNATION CODE

VACON® type designation code is formed of a nine-segment code and optional +codes. Each segment of the type designation code uniquely corresponds to the product and options you have ordered. The format of the code is as follows:

VACON0020-3L-0009-4-X +xxxx +yyyy

VACON

This segment is common for all products.

0020

Product range:

0020 = Vacon 20

3L

Input/Function:

3L = Three-phase input

1L = Single-phase input

0009

Drive rating in ampere; e.g. 0009 = 9 A

See Table 27 and Table 29 for all the drive ratings

4

Supply voltage:

2 = 208-240 V

4 = 380-480 V

X

- IP66/Type 4X enclosure

+xxxx +yyyy

Additional codes.

Examples of additional codes:

+HMTX

Text keypad IP66

+QDSS

Integrated disconnect switch

+QDSH

Simple operator panel

2.2 ORDER CODES

The order codes for Vacon 20 X drive family are shown in the following table:

| Frame size | Order code | Description |
|------------------------------------|-----------------------|------------------------|
| Supply voltage 3AC 208-240V | | |
| MU2 | VACON0020-3L-0004-2-X | 0.75 kW - 1.0 HP drive |
| | VACON0020-3L-0005-2-X | 1.1 kW - 1.5 HP drive |
| | VACON0020-3L-0007-2-X | 1.5 kW - 2.0 HP drive |
| MU3 | VACON0020-3L-0011-2-X | 2.2 kW - 3.0 HP drive |
| | VACON0020-3L-0012-2-X | 3.0 kW - 4.0 HP drive |
| | VACON0020-3L-0017-2-X | 4.0 kW - 5.0 HP drive |
| Supply voltage 1AC 208-240V | | |
| MU2 | VACON0020-1L-0004-2-X | 0.75 kW - 1.0 HP drive |
| | VACON0020-1L-0005-2-X | 1.1 kW - 1.5 HP drive |
| | VACON0020-1L-0007-2-X | 1.5 kW - 2.0 HP drive |
| Supply voltage 3AC 380-480V | | |
| MU2 | VACON0020-3L-0003-4-X | 0.75 kW - 1.0 HP drive |
| | VACON0020-3L-0004-4-X | 1.1 kW - 1.5 HP drive |
| | VACON0020-3L-0005-4-X | 1.5 kW - 2.0 HP drive |
| | VACON0020-3L-0006-4-X | 2.2 kW - 3.0 HP drive |
| | VACON0020-3L-0008-4-X | 3.0 kW - 4.0 HP drive |
| MU3 | VACON0020-3L-0009-4-X | 4.0 kW - 5.0 HP drive |
| | VACON0020-3L-0012-4-X | 5.5 kW - 7.5 HP drive |
| | VACON0020-3L-0016-4-X | 7.5 kW - 10.0 HP drive |

Table 3. Order codes of Vacon 20 X.

For all technical details, see chapter 7.

2.3 UNPACKING AND LIFTING THE AC DRIVE

The weights of the AC drives vary according to frame size. Note the weights of each individual frame size in Table 4 below.

| Frame | Weight | |
|-------|--------|------|
| | [kg] | [lb] |
| MU2 | 3.4 | 7.5 |
| MU3 | 6.0 | 13.2 |

Table 4. Frame weights.

VACON® 20 X drives have undergone scrupulous tests and quality checks at the factory before they are delivered to the customer. However, after unpacking the product, check that no signs of transport damage are to be found on the product and that the delivery is complete.

Should the drive have been damaged during shipping, please contact the cargo insurance company or the carrier in the first instance.

2.4 ACCESSORIES

After lifting the converter out, check that the delivery is complete and the following accessories are included:

| Item | Quantity | Purpose |
|----------------------------|----------|--|
| STO terminal connector | 1 | Six pin black connector (see Figure 9) to use STO function |
| M3.5 x 8 TapTite screw | 4 | Screws for control cable clamps |
| M1-3 Cable clamp | 2 | Clamping control cables |
| 'Product modified' sticker | 1 | Information about modifications |
| HMI cap* | 1 | Closing cap for the HMI connector |

Table 5. Content of accessory bag.

*. Provided only if the drive is delivered with the keypad mounted.

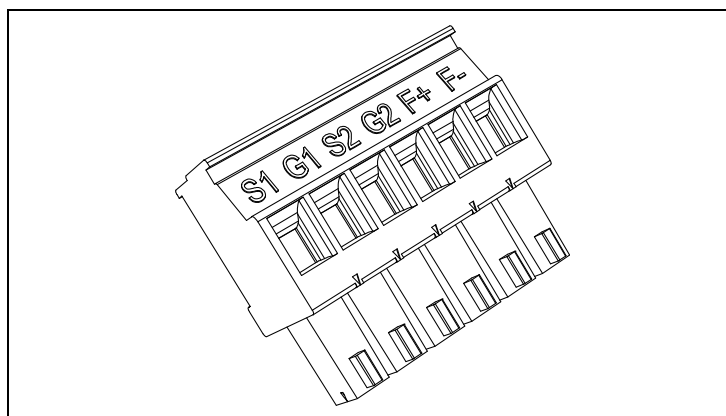

Figure 9. STO connector.

2.4.1 'PRODUCT MODIFIED' STICKER

In the small plastic bag included in the delivery, you will find a silver *Product modified* sticker. The purpose of the sticker is to notify the service staff about the modifications made in the AC drive. Attach the sticker on the side of the AC drive to avoid losing it. Should the AC drive be later modified, mark the change on the sticker.

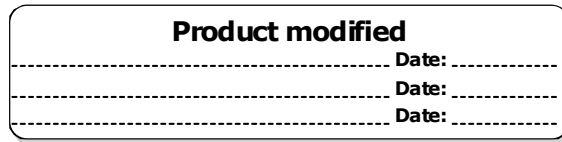

Figure 10. 'Product modified' sticker.

2.4.2 DISPOSAL

| | |
|--|---|
| | <p>When the device reaches the end of its operating life do not dispose of it as a part of standard household garbage. Main components of the product can be recycled, but some need to be fragmented to separate different types of materials and components that need to be treated as special waste from electrical and electronic components. To ensure environmentally sound and safe recycling treatment, the product can be taken to appropriate recycling center or returned to the manufacturer.</p> <p>Observe local and other applicable laws as they may mandate special treatment for specific components or special treatment may be ecologically sensible.</p> |
|--|---|

3. MOUNTING

The AC drive **has to be mounted** on the wall or on the back plane of a cubicle. Ensure that the mounting plane is relatively even. Both frame sizes can be mounted in any position. The drive shall be fixed with four screws (or bolts, depending on the unit size).

3.1 DIMENSIONS

3.1.1 FRAME MU2 AND MU3

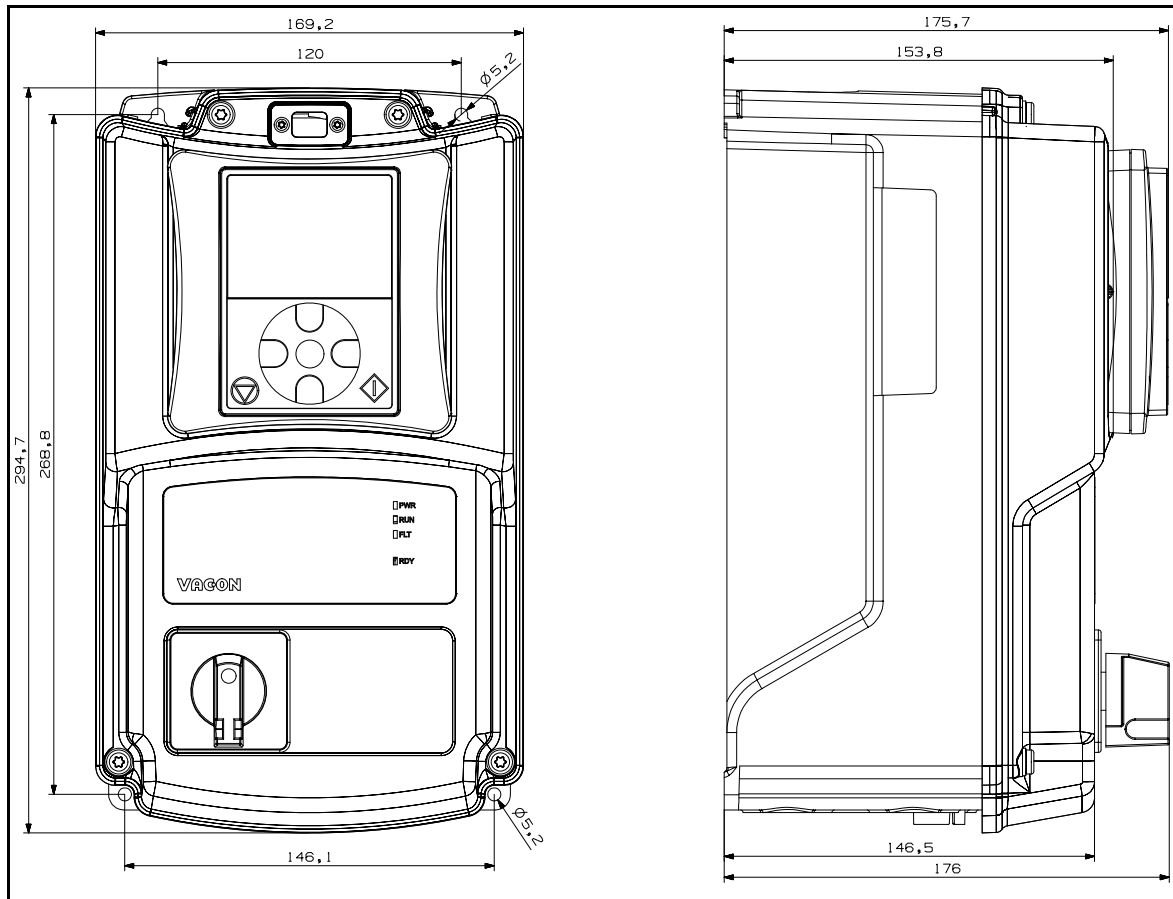

Figure 11. VACON® 20 X, MU2.

| Frame | Dimensions W x H x D | |
|-----------|-----------------------|---------------------|
| | [mm] | [in] |
| MU2 | 169.2 x 294.7 x 153.8 | 6.66 x 11.60 x 6.06 |
| MU2 +HMTX | 169.2 x 294.7 x 175.7 | 6.66 x 11.60 x 6.92 |
| MU2 +QDSS | 169.2 x 294.7 x 176 | 6.66 x 11.60 x 6.93 |

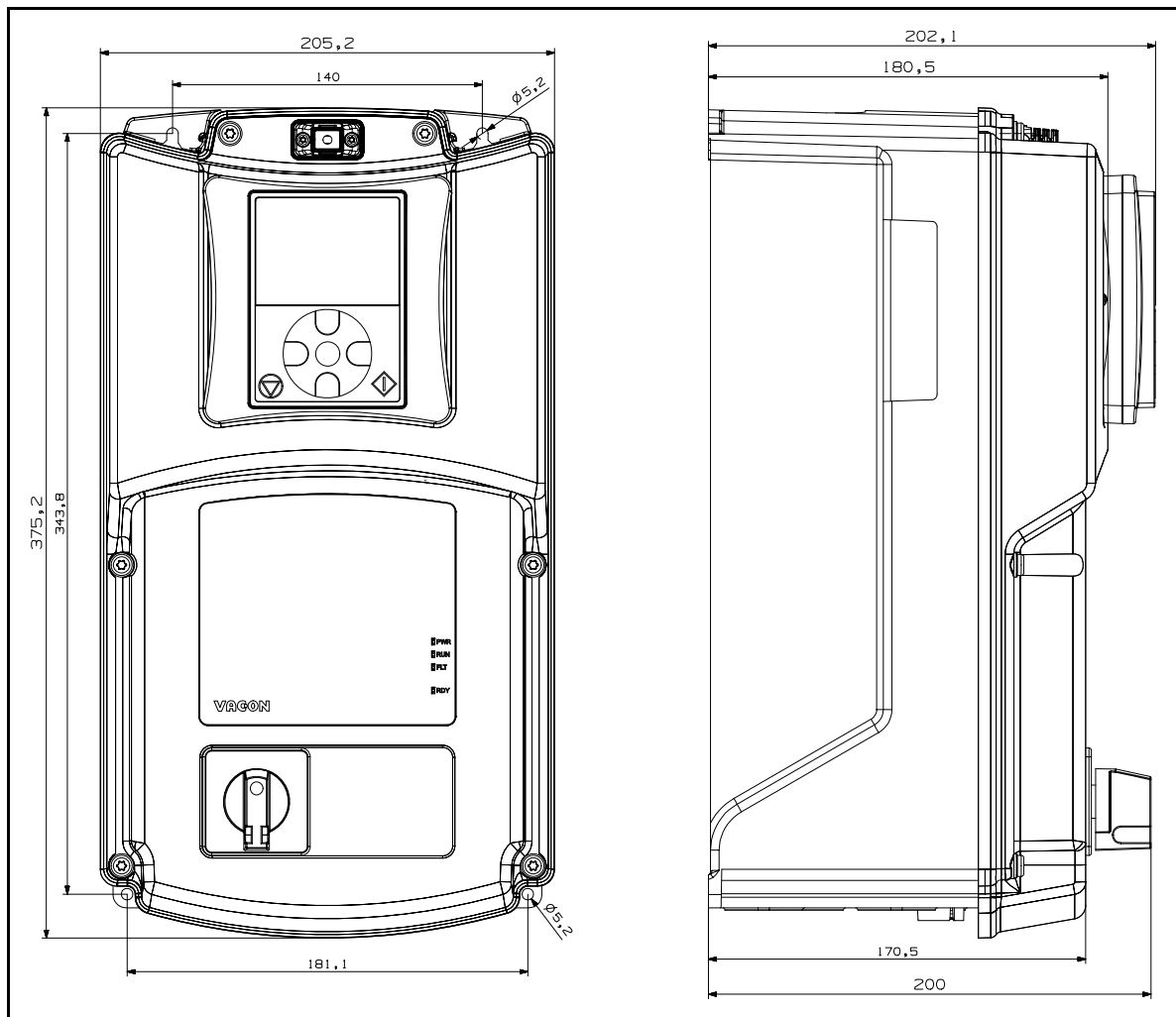

Figure 12. VACON® 20 X, MU3.

| Frame | Dimensions W x H x D | |
|-----------|-----------------------|---------------------|
| | [mm] | [in] |
| MU3 | 205.2 x 375.2 x 180.5 | 8.08 x 14.77 x 7.11 |
| MU3 +HMTX | 205.2 x 375.2 x 202.1 | 8.08 x 14.77 x 7.96 |
| MU3 +QDSS | 205.2 x 375.2 x 200.0 | 8.08 x 14.77 x 7.87 |

The drive can be mounted in vertical or horizontal position on the wall or any other relatively even mounting plane or machine frame and fixed with the screws recommended in Table 6. Recommended screw or bolt size for MU2 and MU3 is M5.

| Frame | Screw number | Screw size |
|-------|--------------|------------|
| MU2 | 4 | M5 |
| MU3 | 4 | M5 |

Table 6. Screws for wall mounting.

3.2 COOLING

The AC drive produces heat in operation and is cooled down by air circulated by a fan. Enough free space shall be left around the AC drive to ensure sufficient air circulation and cooling. Different acts of maintenance may also require certain amount of free space.

The minimum clearances given in Table 7 should be respected. It is also important to ensure that the temperature of the cooling air does not exceed the maximum environment temperature of the converter.

Contact our factory for more information on required clearances in different installations.

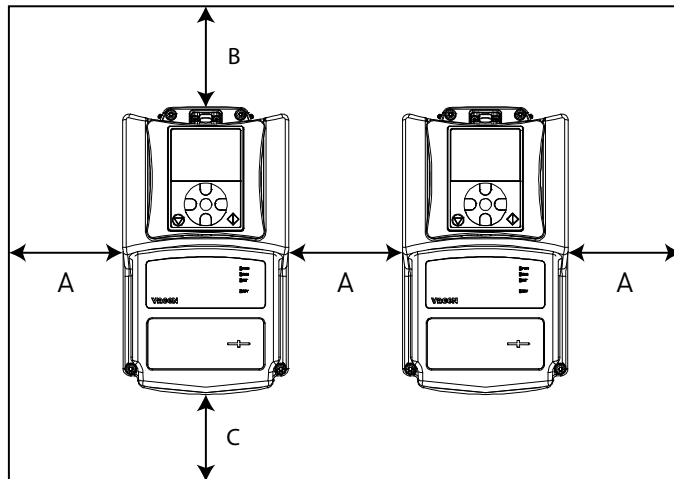

| Min clearance [mm] | | | |
|--------------------|----|----|----|
| Type | A | B | C |
| MU2 | 15 | 30 | 60 |
| MU3 | 15 | 30 | 80 |

Table 7. Min. clearances around AC drive.

A = Clearance left and right from the drive

B = Clearance above the drive

C = Clearance underneath the AC drive

Figure 13. Installation space.

| Type | Cooling air required [m ³ /h] |
|------|--|
| MU2 | 50 |
| MU3 | 110 |

Table 8. Required cooling air.

Note that if several units are mounted **above** each other the required free space equals B+C (see the Figure 14.). Moreover, the outlet air used for cooling by lower unit must be directed away from the air intake of the upper unit by means of e.g. a piece of metal plate fixed to the wall between the drives as shown in Figure 14..

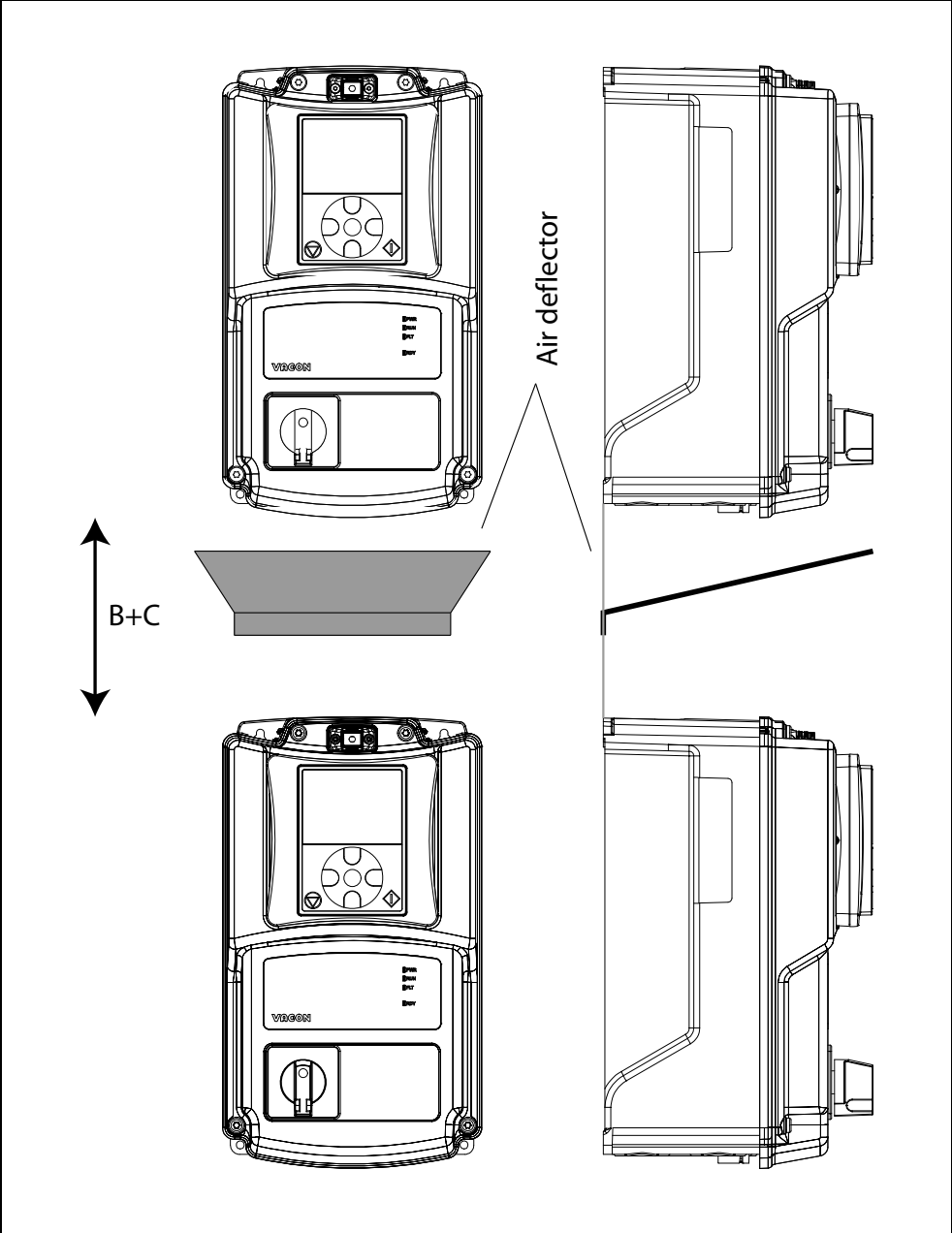

Figure 14. Installation space when drives are mounted on top of each other.

4. POWER CABLING

The mains cables are connected to terminals L1, L2 and L3 (or L and N) and the motor cables to terminals marked with U, V and W. See principal connection diagrams in Figure 15 and Figure 16.

See also Table for the cable recommendations for different EMC levels.

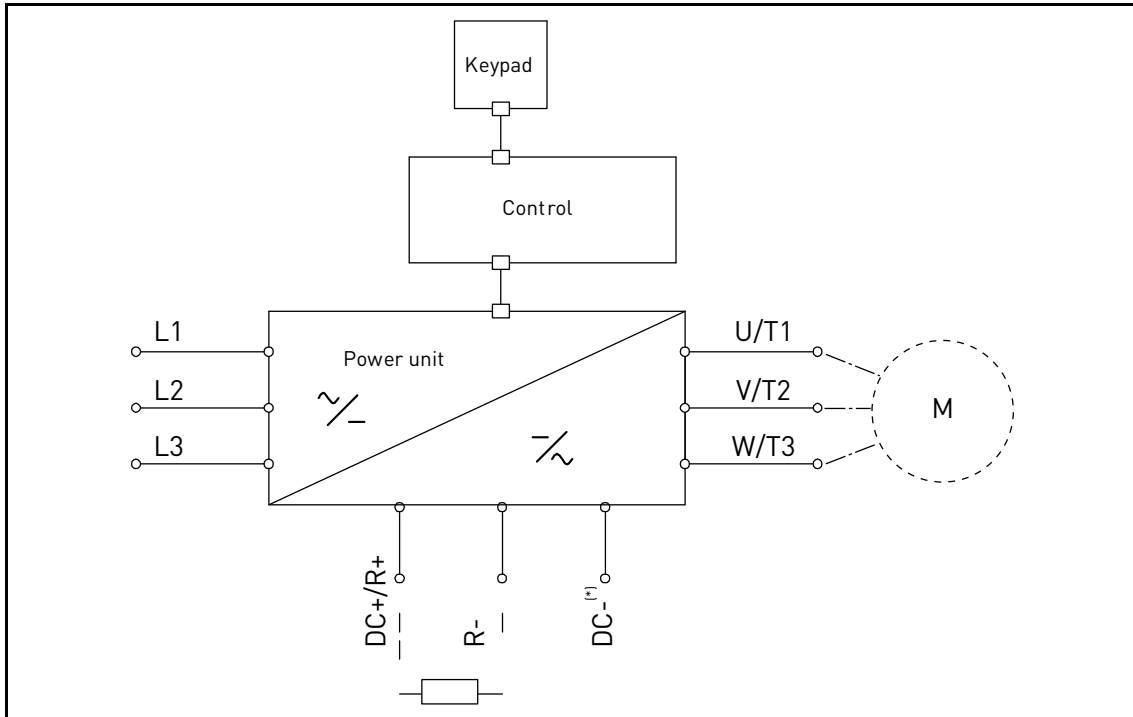

Figure 15. Principal connection diagram (three-phase version).

* only MU3.

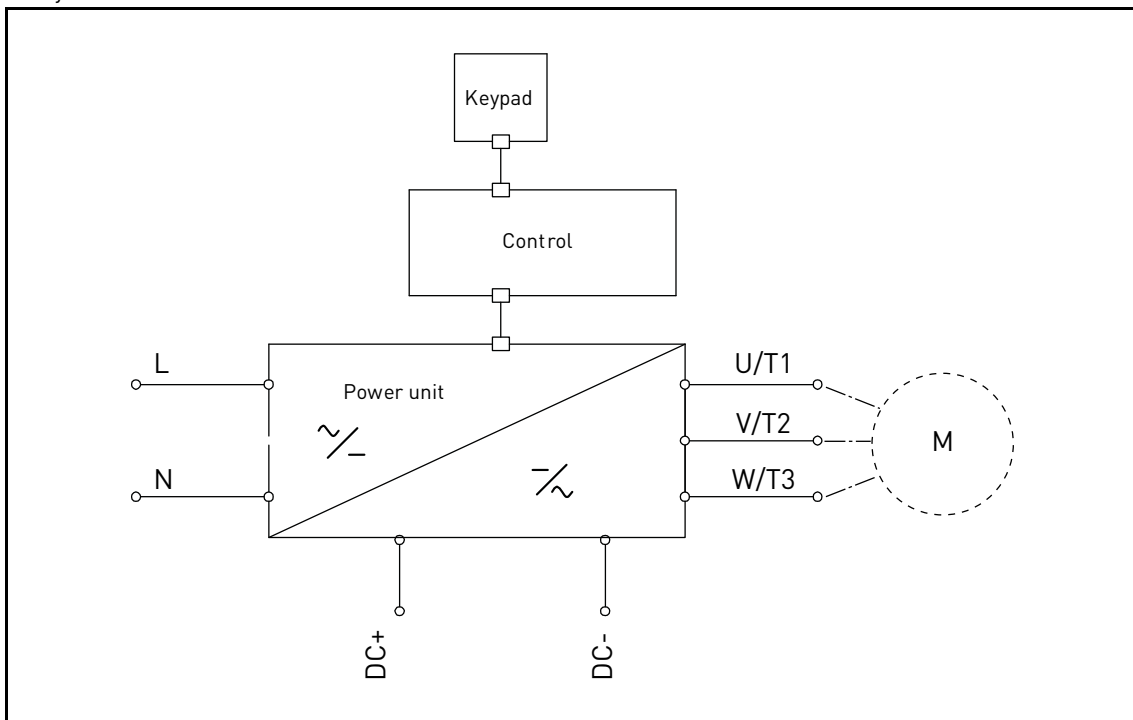

Figure 16. Principal connection diagram (single-phase version)

Use cables with heat resistance in accordance with the application requirements. The cables and the fuses must be dimensioned according to the AC drive nominal OUTPUT current which you can find on the rating plate.

| Cable type | EMC levels | | |
|---------------|-----------------------------|-----------------------------|-------------|
| | 1 st environment | 2 nd environment | |
| | Category C1 and C2 | Category C3 | Category C4 |
| Mains cable | 1 | 1 | 1 |
| Motor cable | 3* | 2 | 2 |
| Control cable | 4 | 4 | 4 |

Table 9: Cable types required to meet standards.

- 1 = Power cable intended for fixed installation and the specific mains voltage. Shielded cable not required. (MCMK or similar recommended).
- 2 = Symmetrical power cable equipped with concentric protection wire and intended for the specific mains voltage. (MCMK or similar recommended). See Figure 17.
- 3 = Symmetrical power cable equipped with compact low-impedance shield and intended for the specific mains voltage. [MCCMK, EMCCK or similar recommended; Recommended cable transfer impedance (1...30MHz) max. 100mohm/m]. See Figure 17.
*360° earthing of the shield with cable glands in motor end needed for EMC category C2.
- 4 = Screened cable equipped with compact low-impedance shield (JAMAK, SAB/ÖZCuY-0 or similar).

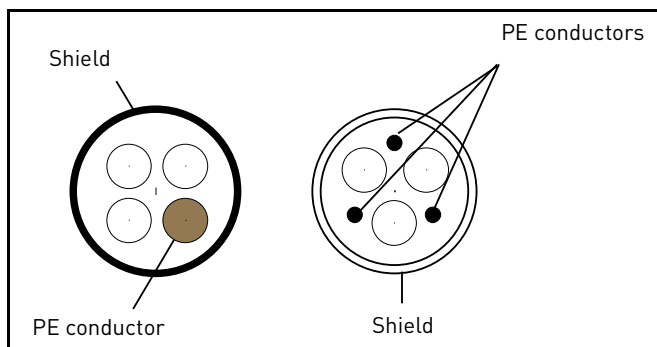

Figure 17.

NOTE: The EMC requirements are fulfilled at factory defaults of switching frequencies (all frames).

NOTE: If safety switch is connected the EMC protection shall be continuous over the whole cable installation.

4.1 CIRCUIT BREAKER

Please, disconnect the drive via an external circuit breaker. You have to provide a switching device between supply and main connection terminals.

When connecting the input terminals to the power supply using a circuit breaker, observe that this is of **type B or type C** and ensure it has a **capacity of 1.5 to 2 times of the inverter's rated current** (see Table 27 and Table 29).

NOTE: circuit breaker is not allowed in installations where C-UL is required. Only fuses are recommended.

4.2 UL STANDARDS ON CABLING

To meet the UL (Underwriters Laboratories) regulations, use a UL-approved copper cable with a minimum heat-resistance of +70/75°C. Use Class 1 wire only.

The units are suitable for use on a circuit capable of delivering no more than 50,000 rms symmetrical amperes, 600V AC maximum, when protected by T or J class fuses.



Integral solid state short circuit protection does not provide branch circuit protection. Branch circuit protection must be provided in accordance with the **National Electrical Code** and any additional local codes.

4.3 DESCRIPTION OF THE TERMINALS

The following pictures describe the power terminals and the typical connections in Vacon® 20X drives.

4.3.1 MU2 THREE-PHASE VERSION POWER CONNECTIONS

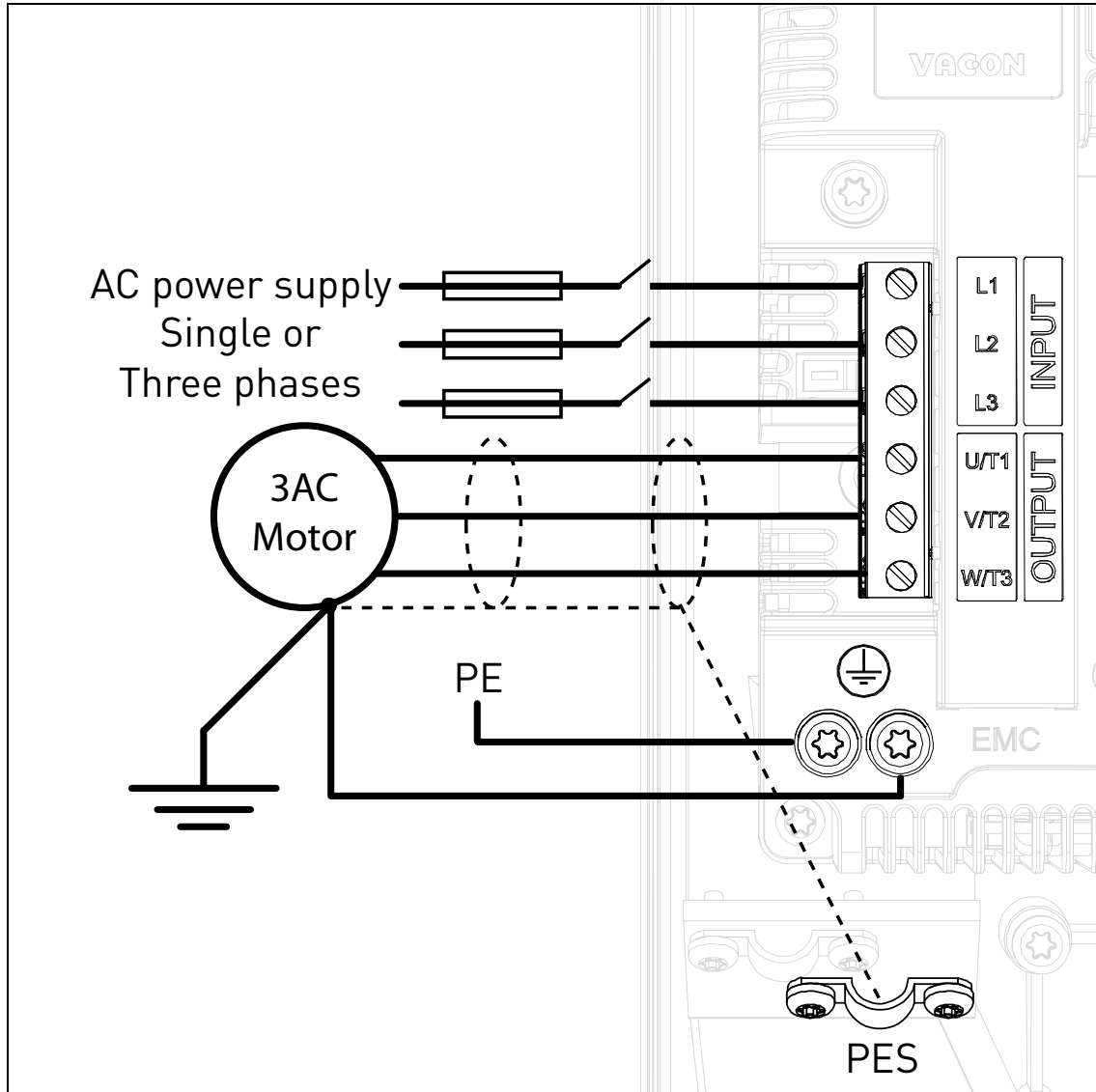

Figure 18. Power connections, MU2 three-phase version.

| Terminal | Description |
|----------------------|---|
| L1 L2 L3 | These terminals are the input connections for the power supply. 230 VAC models can be supplied by single-phase voltage by connecting to L1 and L2 terminals (with derating of 50%). |
| U/T1 V/T2 W/T3 | These terminals are for motor connections. |

Table 10. Description of Vacon 20X MU2 power terminals.

4.3.2 MU2 SINGLE-PHASE VERSION POWER CONNECTIONS

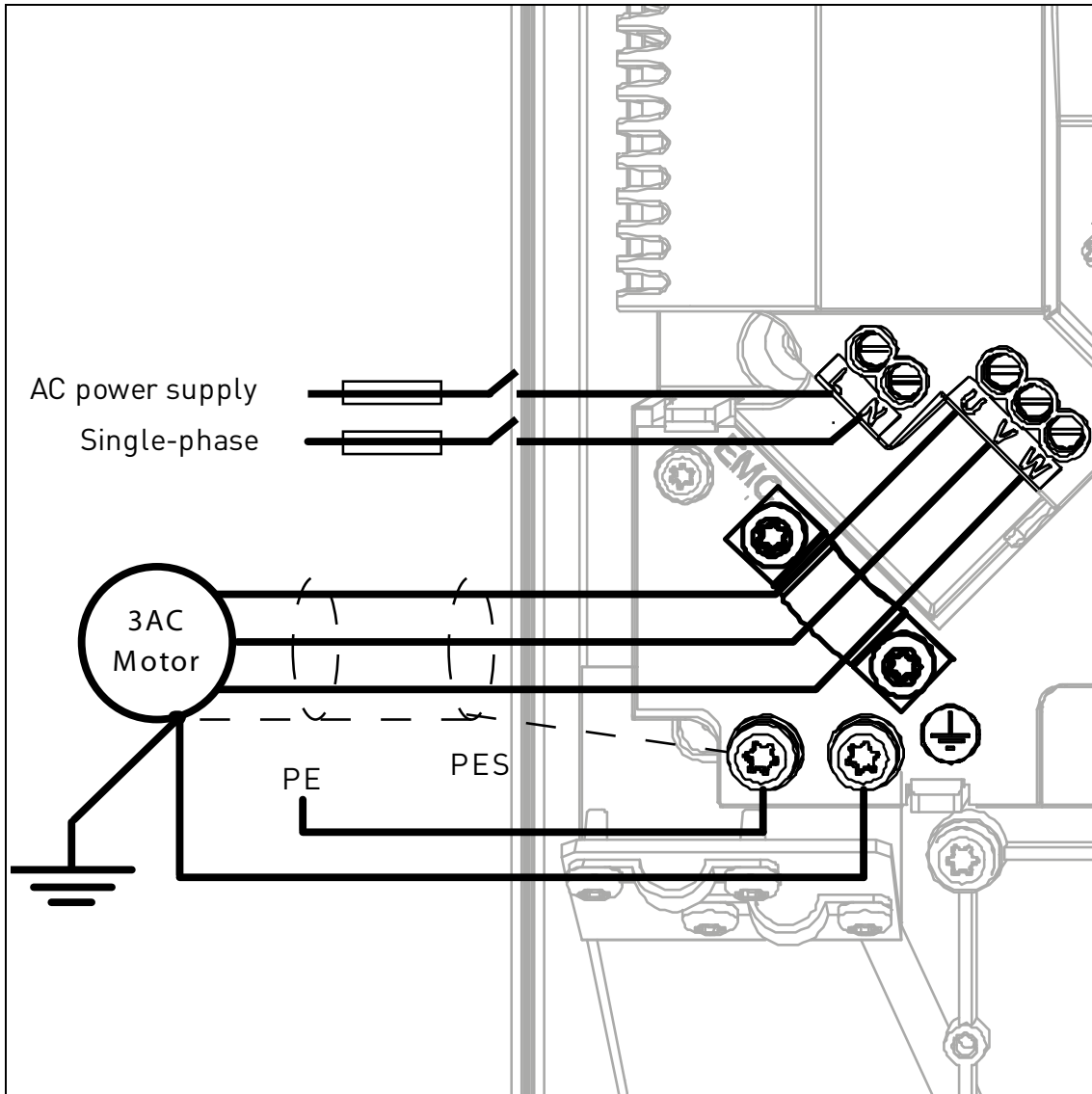

Figure 19. Power connections, MU2 single-phase version.

| Terminal | Description |
|-------------|--|
| L N | These terminals are the input connections for the power supply. Single-phase 230 VAC voltage has to be connected to L and N terminals. |
| U V W | These terminals are for motor connections. |

Table 11. Description of Vacon 20X MU2 power terminals (single-phase version).

4.3.3 MU3 POWER CONNECTIONS

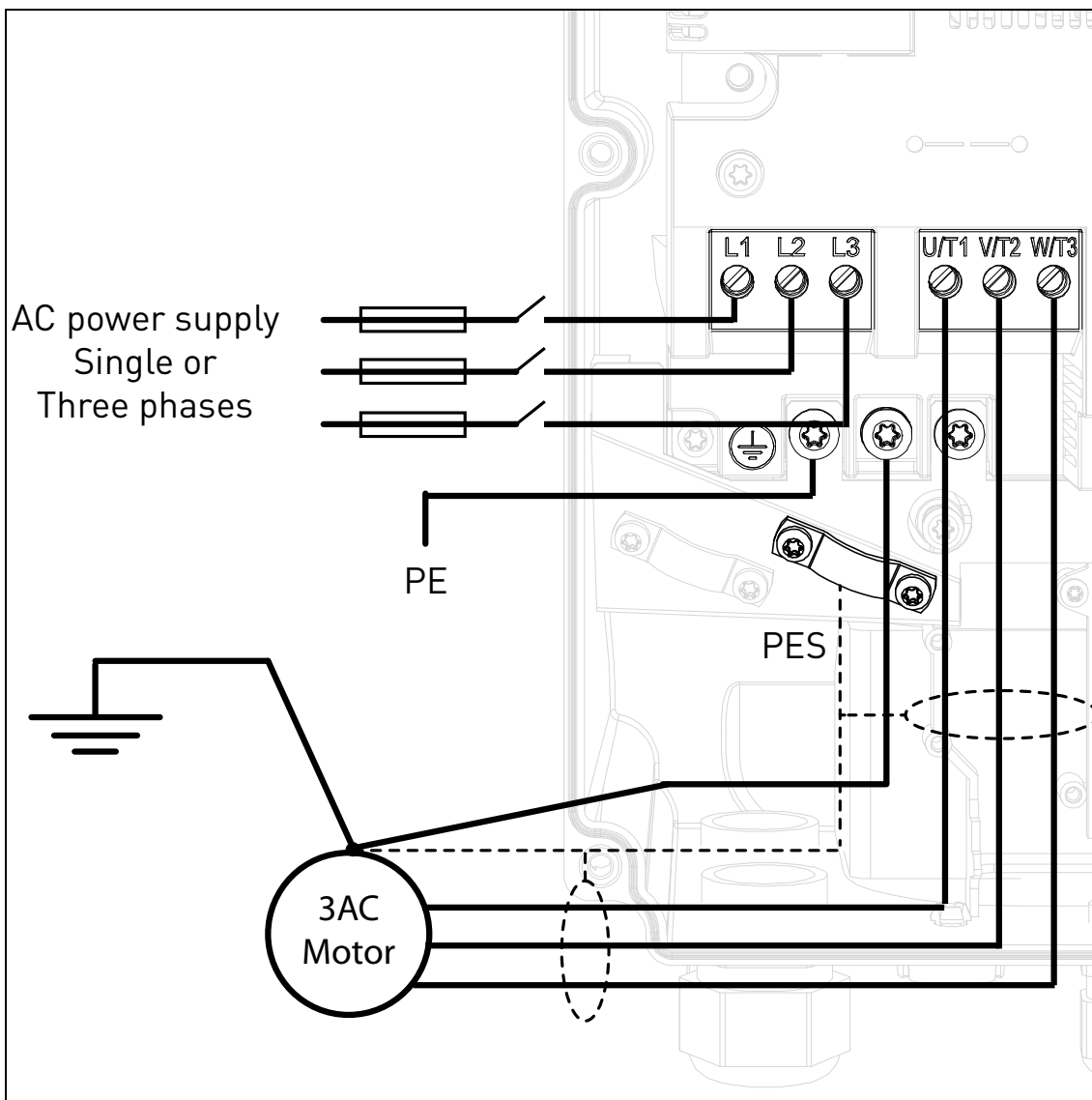

Figure 20. Power connections, MU3.

| Terminal | Description |
|----------------------|---|
| L1 L2 L3 | These terminals are the input connections for the power supply. 230 VAC models can be supplied by single-phase voltage by connecting to L1 and L2 terminals (with derating of 50%). |
| U/T1 V/T2 W/T3 | These terminals are for motor connections. |

Table 12. Description of Vacon 20X power terminals.

4.4 CABLE DIMENSIONING AND SELECTION

Table 13 shows the minimum dimensions of the Cu cables and the corresponding fuse sizes.

These instructions apply only to cases with one motor and one cable connection from the AC drive to the motor. In any other case, ask the factory for more information.

4.4.0.1 CABLE AND FUSE SIZES, FRAMES MU2 AND MU3

The recommended fuse types are gG/gL (IEC 60269-1) or class T (UL & CSA). The fuse voltage rating should be selected according to the supply network. The final selection should be made according to local regulations, cable installation conditions and cable specifications. Bigger fuses than those recommended below shall not be used.

Check that the fuse operating time is less than 0.4 seconds. Operating time depends on used fuse type and impedance of the supply circuit. Consult the factory about faster fuses. Vacon also recommends for high speed J (UL & CSA), aR (UL recognized, IEC 60269-4) and gS (IEC 60269-4) fuse ranges.

| Frame | Type | I _{INPUT} [A] | Fuse (gG/gL) [A] | Mains and motor cable Cu [mm ²] | Terminal cable size | |
|----------------|------------------------------------|---------------------------|------------------------|---|--|---------------------|
| | | | | | Main terminal [mm ²] | Earth terminal |
| MU2 | 0004 2 0003 4 - 0004 4 | 4.3 3.2 - 4.0 | 6 | 3*1.5+1.5 | 0.2 — 2.5 | M4 ring terminal |
| | 0005 2 - 0007 2 0005 4 - 0006 4 | 6.8 - 8.4 5.6 - 7.3 | 10 | 3*1.5+1.5 | 0.2 — 2.5 | M4 ring terminal |
| | 0008 4 | 9.6 | 10 | 3*2.5+2.5 | 0.2 — 2.5 | M4 ring terminal |
| MU2 1-phase | 0004 2 | 8.3 | 20 | (Mains) 2*1.5+1.5 (Motor) 3*1.5+1.5 | 0.2 — 2.5 stranded | M4 ring terminal |
| | 0005 2 | 11.2 | 20 | (Mains) 2*2.5+2.5 (Motor) 3*2.5+2.5 | 0.2 — 2.5 stranded | M4 ring terminal |
| | 0007 2 | 14.1 | 25 | (Mains) 2*2.5+2.5 (Motor) 3*2.5+2.5 | 0.2 — 2.5 stranded | M4 ring terminal |
| MU3 | 0011 2 0009 4 | 13.4 11.5 | 16 | 3*2.5+2.5 | 0.5 — 16.0 | M5 ring terminal |
| | 0012 2 0012 4 | 14.2 14.9 | 20 | 3*2.5+2.5 | 0.5 — 16.0 | M5 ring terminal |
| | 0017 2 0016 4 | 20.6 20.0 | 25 | 3*6+6 | 0.5 — 16.0 | M5 ring terminal |

Table 13. Cable and fuse sizes for VACON® 20 X.

The cable dimensioning is based on the criteria of the International Standard **IEC60364-5-52**: Cables must be PVC-isolated; use only cables with concentric copper shield; Max number of parallel cables is 9.

When using cables in parallel, **NOTE HOWEVER** that the requirements of both the cross-sectional area and the max number of cables must be observed.

For important information on the requirements of the earthing conductor, see chapter Earthing and earth fault protection of the standard.

For the correction factors for each temperature, see International Standard **IEC60364-5-52**.

4.4.0.2 CABLE AND FUSE SIZES, FRAMES MU2 AND MU3, NORTH AMERICA

The recommended fuse types are gG/gL (IEC 60269-1) or class T (UL & CSA). The fuse voltage rating should be selected according to the supply network. The final selection should be made according to local regulations, cable installation conditions and cable specifications. Bigger fuses than those recommended below shall not be used.

Check that the fuse operating time is less than 0.4 seconds. Operating time depends on used fuse type and impedance of the supply circuit. Consult the factory about faster fuses. Vacon also recommends for high speed J (UL & CSA), aR (UL recognized, IEC 60269-4) and gS (IEC 60269-4) fuse ranges.

| Frame | Type | I _{INPUT} [A] | Fuse (class T) [A] | Mains and motor cable Cu | Terminal cable size | |
|----------------|------------------------------------|---------------------------|--------------------------|--------------------------------|---------------------|-------------------|
| | | | | | Main terminal | Earth terminal |
| MU2 | 0004 2 | 4.3 | 6 | AWG14 | AWG24-AWG12 | AWG17-AWG10 |
| | 0003 4 - 0004 4 | 3.2 - 4.0 | | | | |
| | 0005 2 - 0007 2 0005 4 - 0006 4 | 6.8 - 8.4 5.6 - 7.3 | 10 | AWG14 | AWG24-AWG12 | AWG17-AWG10 |
| | 0008 4 | 9.6 | 10 | AWG14 | AWG24-AWG12 | AWG17-AWG10 |
| MU2 1-phase | 0004 2 | 8.3 | 20 | AWG14 | AWG24-AWG12 | AWG17-AWG10 |
| | 0005 2 | 11.2 | 20 | AWG14 | AWG24-AWG12 | AWG17-AWG10 |
| | 0007 2 | 14.1 | 25 | AWG14 | AWG24-AWG12 | AWG17-AWG10 |
| MU3 | 0011 2 | 13.4 | 15 | AWG14 | AWG20-AWG6 | AWG17-AWG10 |
| | 0009 4 | 11.5 | | | | |
| | 0012 2 | 14.2 | 20 | AWG12 | AWG20-AWG6 | AWG17-AWG10 |
| | 0012 4 | 14.9 | | | | |
| | 0017 2 | 20.6 | 25 | AWG10 | AWG20-AWG6 | AWG17-AWG10 |
| 0016 4 | 20.0 | | | | | |

Table 14. Cable and fuse sizes for VACON® 20 X, North America.

The cable dimensioning is based on the criteria of the **Underwriters' Laboratories UL508C**: Cables must be PVC-isolated; Max ambient temperature +40 °C (104 °F), max temperature of cable surface +70/+75 °C (158/167 °F); Use only cables with concentric copper shield; Max number of parallel cables is 9.

When using cables in parallel, **NOTE HOWEVER** that the requirements of both the cross-sectional area and the max number of cables must be observed.

For important information on the requirements of the earthing conductor, see standard Underwriters' Laboratories UL508C.

For the correction factors for each temperature, see the instructions of standard **Underwriters' Laboratories UL508C**.

4.5 BRAKE RESISTOR CABLES

VACON[®] 20 X AC drives(three-phase version) are equipped with terminals for an optional external brake resistor.

For MU2, brake resistor wires with faston 6.3 mm have to be used.

For MU3, a PCB terminal block with push-in spring-cage connector is provided. Stranded wires (max. 4 mm²) with ferrules should be used.

See Table 30 and Table 31 for the resistor ratings.

4.6 CONTROL CABLES

For information on control cables see chapter Control unit cabling.

4.7 CABLE INSTALLATION

- Before starting, check that none of the components of the AC drive is live. Read the warnings in chapter 1 carefully
- Place the motor cables sufficiently far from other cables
- Avoid placing the motor cables in long parallel lines with other cables.
- If the motor cables run in parallel with other cables note the minimum distances between the motor cables and other cables given in table below.

| Distance between cables, [m] | Shielded cable, [m] |
|------------------------------|---------------------|
| 0.3 | ≤ 50 |
| 1.0 | ≤ 200 |

- The given distances also apply between the motor cables and signal cables of other systems.
- The **maximum length** for motor cables is **30m**
- The motor cables should cross other cables at an angle of 90 degrees.
- If cable insulation checks are needed, see chapter Cable and motor insulation checks.

Start the cable installation according to the instructions below:

| | |
|----------|--|
| 1 | Strip the motor and mains cables as recommended below. |
|----------|--|

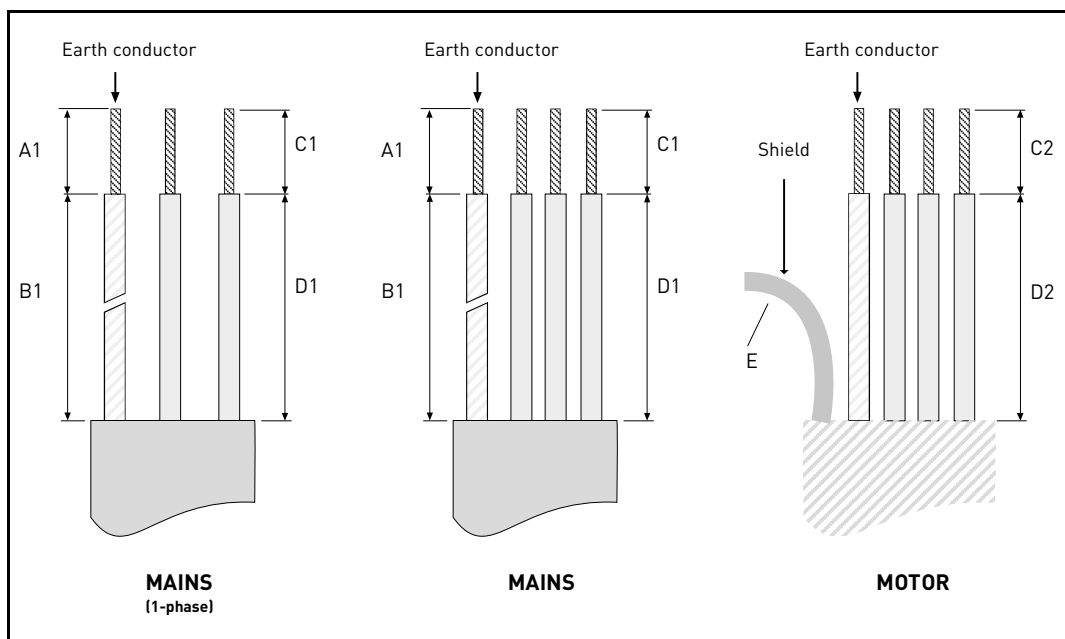

Figure 21. Stripping of cables.

| Frame | A1 | B1 | C1 | D1 | C2 | D2 | E |
|-------------|----|----|----|----|----|----|----------------------------|
| MU2 | 8 | 8 | 8 | 20 | 36 | 20 | Leave as short as possible |
| MU2 1-phase | 7 | 8 | 8 | 20 | 36 | 20 | |
| MU3 | 8 | 8 | 8 | 20 | 36 | 20 | |

Table 15. Cables stripping lengths [mm].

2

- Remove the plastic cover of the drive as shown in Figure 22.

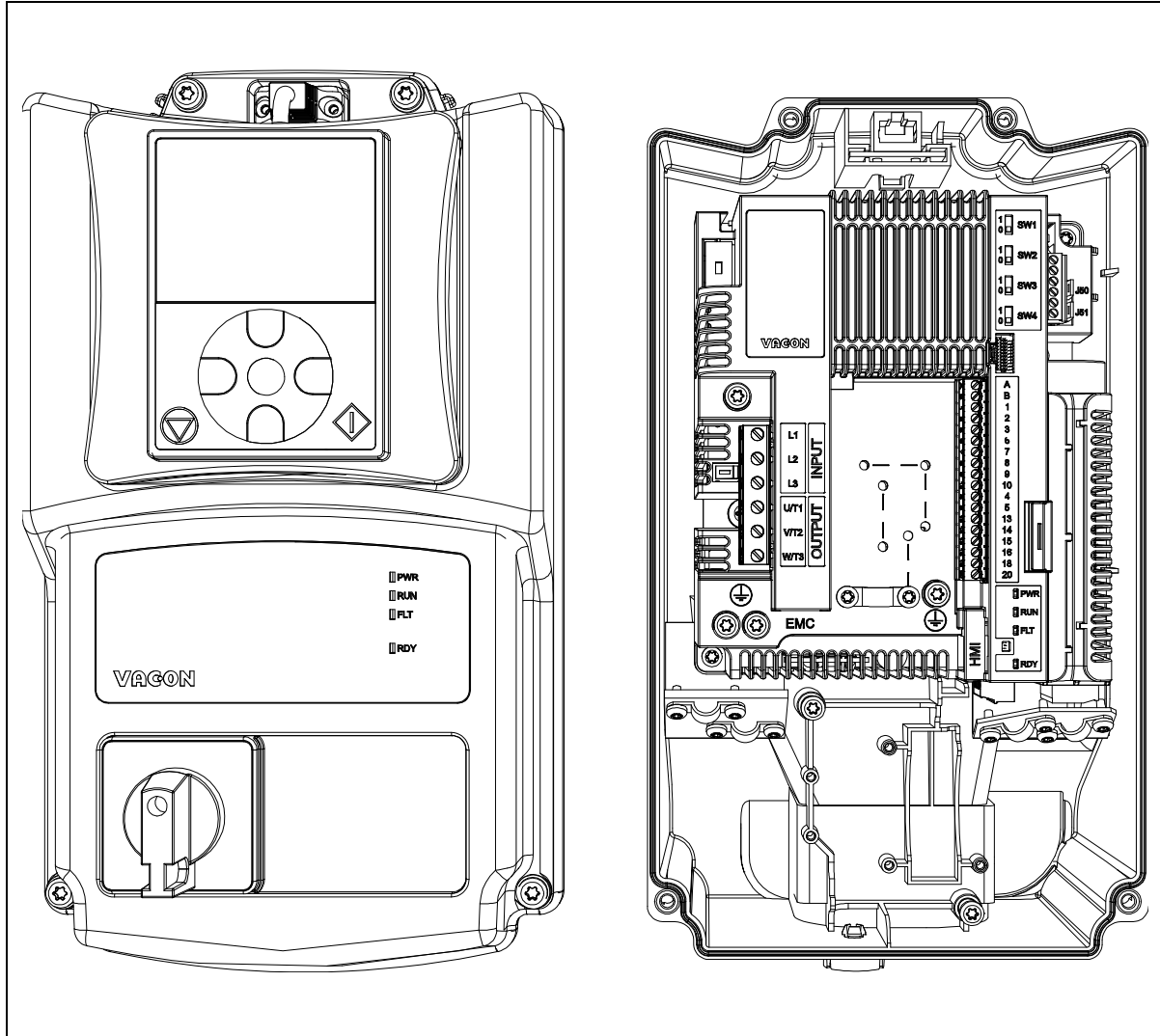

Figure 22. MU2 example: open cover.

IEC installations:

3

- The cable entries consists of several openings available for the cables with ISO metric thread.
- Open only the inlet holes where you need to run the cables.

4

- Choose the correct cable glands (in compliance with CE rules) according to drive and cable size as shown in the following pictures.

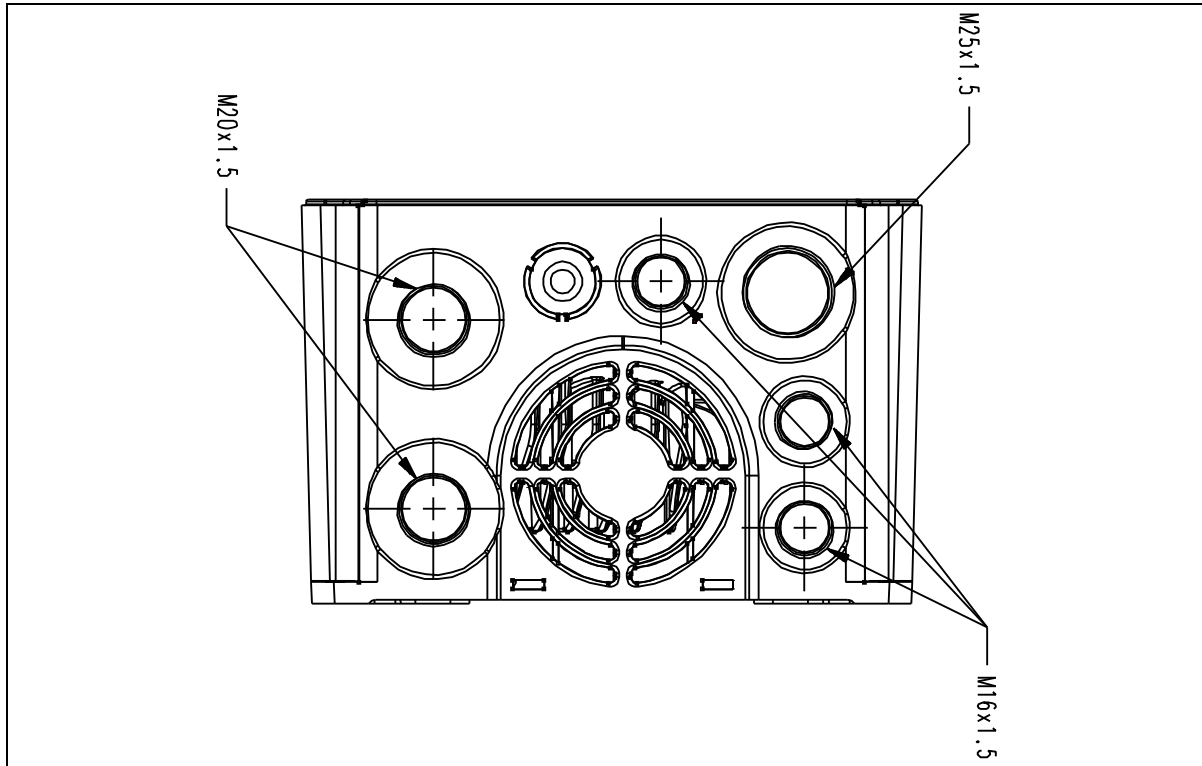

Figure 23. Cable entries, MU2.

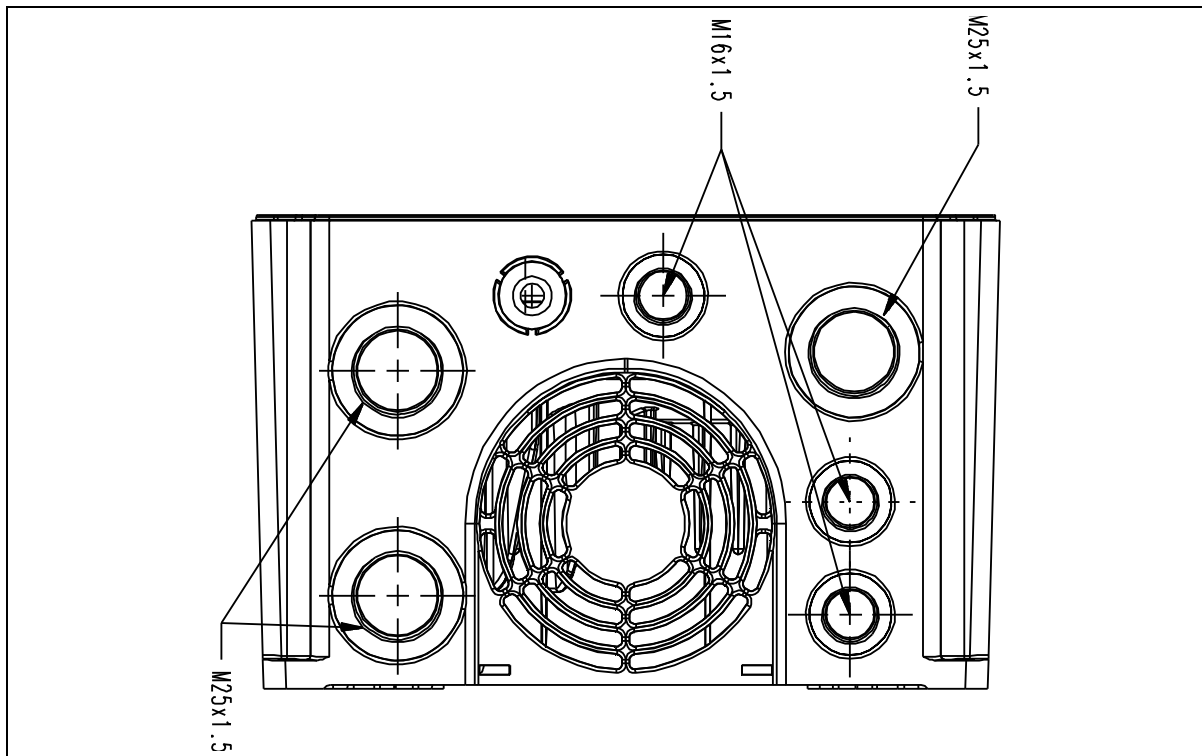

Figure 24. Cable entries, MU3.

| | |
|----------|--|
| 5 | <ul style="list-style-type: none"> • Cable glands must be made of plastic materials. They are used for sealing cables passing through cable entries to ensure the characteristics of the enclosure. |
|----------|--|

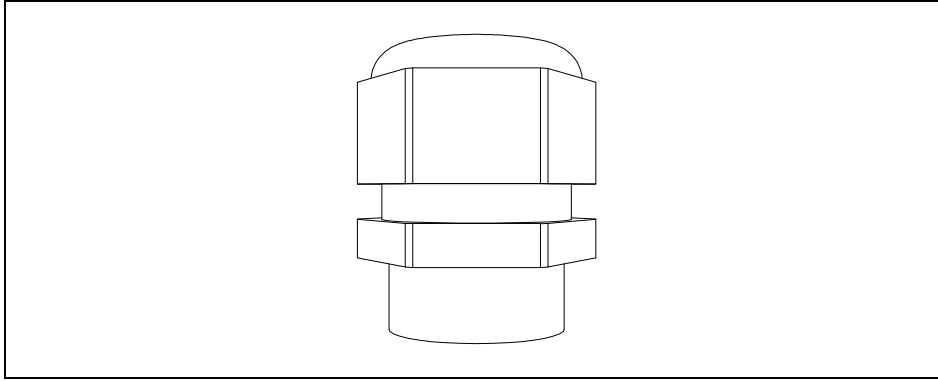

Figure 25. Cable gland.



Plastic cable glands are recommended. If metal cable glands are needed, all insulation system and protective earthing requirements have to be fulfilled in accordance with the national electrical regulations and IEC 61800-5-1.

6

- Screw the cable glands (in compliance with CE rules) on the cable entry holes using the proper tightening torque as shown in Table 16.

Tightening torque and dimensions of cable glands:

| Frame | Gland screw type [metric] | Tightening torque | |
|-------|---------------------------|-------------------|---------|
| | | [Nm] | lbs-in. |
| MU2 | M16 | 1.0 | 8.9 |
| | M20 | 2.0 | 17.7 |
| | M25 | 4.0 | 35.5 |
| MU3 | M16 | 1.0 | 8.9 |
| | M25 | 4.0 | 35.5 |

Table 16. Tightening torque and dimension of cable glands.

UL installations:

| | |
|----------|---|
| 7 | <ul style="list-style-type: none"> • Flexible conduit (plastic or metallic) are used as raceway for wires and cables in accordance with the National Electrical Code. |
| 8 | <ul style="list-style-type: none"> • To connect NPT conduits to the metric threads of cable entries, adapters must be used. These adapters must first be connected to the cable entries plate, using the proper tightening torque as shown in the Table 16, and then to the pipes according to UL regulations. |
| 9 | <ul style="list-style-type: none"> • For MU2 three NPT-to-Metric adapters must be used: number two 1/2" - M20 adapters and number one 3/4" - M25 adapter. See Table 17 for further details. |

| | |
|-----------|---|
| 10 | <ul style="list-style-type: none"> For MU3 three NPT-to-Metric adapters must be used: 3/4" - M25 adapters. See Table 17 for further details. |
|-----------|---|

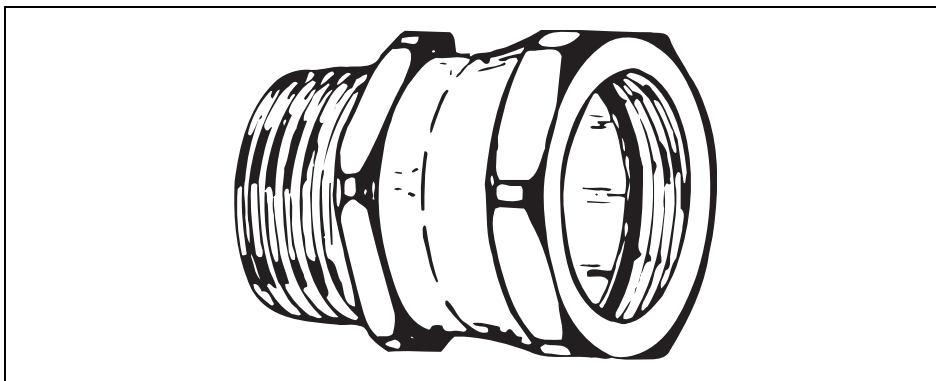

Figure 26. NPT-to-metric threads adapter.

| | |
|-----------|--|
| 11 | <ul style="list-style-type: none"> Teflon tape has to be used to ensure that you get a water tight seal on pipe joints. |
| 12 | <ul style="list-style-type: none"> Start by cleaning the male threads at the end of the pipe with a clean rag. Place the end of the Teflon tape on the second thread in and hold it in place with one hand. Wrap the tape in the same direction of the threads. Keep tension on the tape and wrap it several times working away from the end of the NPT pipe. When you have finished wrapping the Teflon smooth the loose end down into the threads. Screw the NPT-to-metric adapter on the cable entry plate using the proper tightening torque. See Table 17 for more details. Screw the NPT pipes on the adapters. |

Tightening torque of NPT adapters to metric threads cable entries:

| Frame | Thread male metric | Thread female NPT | Tightening torque | |
|-------|--------------------|-------------------|-------------------|---------|
| | | | [Nm] | lbs-in. |
| MU2 | M20 | 1/2" | 2.0 | 17.7 |
| | M25 | 3/4" | 4.0 | 35.5 |
| MU3 | M25 | 3/4" | 4.0 | 35.5 |

Table 17. Tightening torque of NPT adapters to metric threads cable entries.



The Vacon 20X drive is IP66/Type 4X rated. To keep this rating, the use of a sealed conduit is required: if the approved conduit is not used, all warranty claims against water will be void.

Cables installation:

| | |
|-----------|---|
| 13 | <ul style="list-style-type: none"> Pass the cables (supply cable, motor cable, brake cable and I/O cables) through the pipes and adapters (UL installations) or through the cable glands (IEC installations) and cable entries. |
| 14 | <ul style="list-style-type: none"> Detach the cable clamps and the grounding clamps. |
| 15 | <p>Connect the stripped cables:</p> <ul style="list-style-type: none"> Expose the shield of the motor cable in order to make a 360-degree connection with the cable clamp (reverse the shield over the plastic cover of the cable and fix all together). Connect the phase conductors of the supply and motor cables into their respective terminals. Form the rest of the cable shield of both cables into "pigtailed" and make a grounding connection with the clamp. Make the pigtailed just long enough to reach and be fixed to the terminal - no longer. |

Tightening torques of cable terminals:

| Frame | Type | Tightening torque Power and motor terminals | | Tightening torque EMC grounding clamps | | Tightening torque, Grounding terminals | |
|------------|---------------|---|-----------|--|---------|---|---------|
| | | [Nm] | lbs-in. | [Nm] | lbs-in. | [Nm] | lbs-in. |
| MU2 | 0003 4—0008 4 | 0.5—0.6 | 4.5—5.3 | 1.5 | 13.3 | 2.0 | 17.7 |
| | 0004 2—0007 2 | | | | | | |
| MU3 | 0009 4—0016 4 | 1.2—1.5 | 10.6—13.3 | 1.5 | 13.3 | 2.0 | 17.7 |
| | 0011 2—0017 2 | | | | | | |

Table 18. Tightening torques of terminals.

| | |
|-----------|--|
| 16 | <ul style="list-style-type: none"> Check the connection of the earth cable to the motor and the AC drive terminals marked with . |
|-----------|--|

4.8 WIRING WAY

In the following picture an example of wire cabling is given:

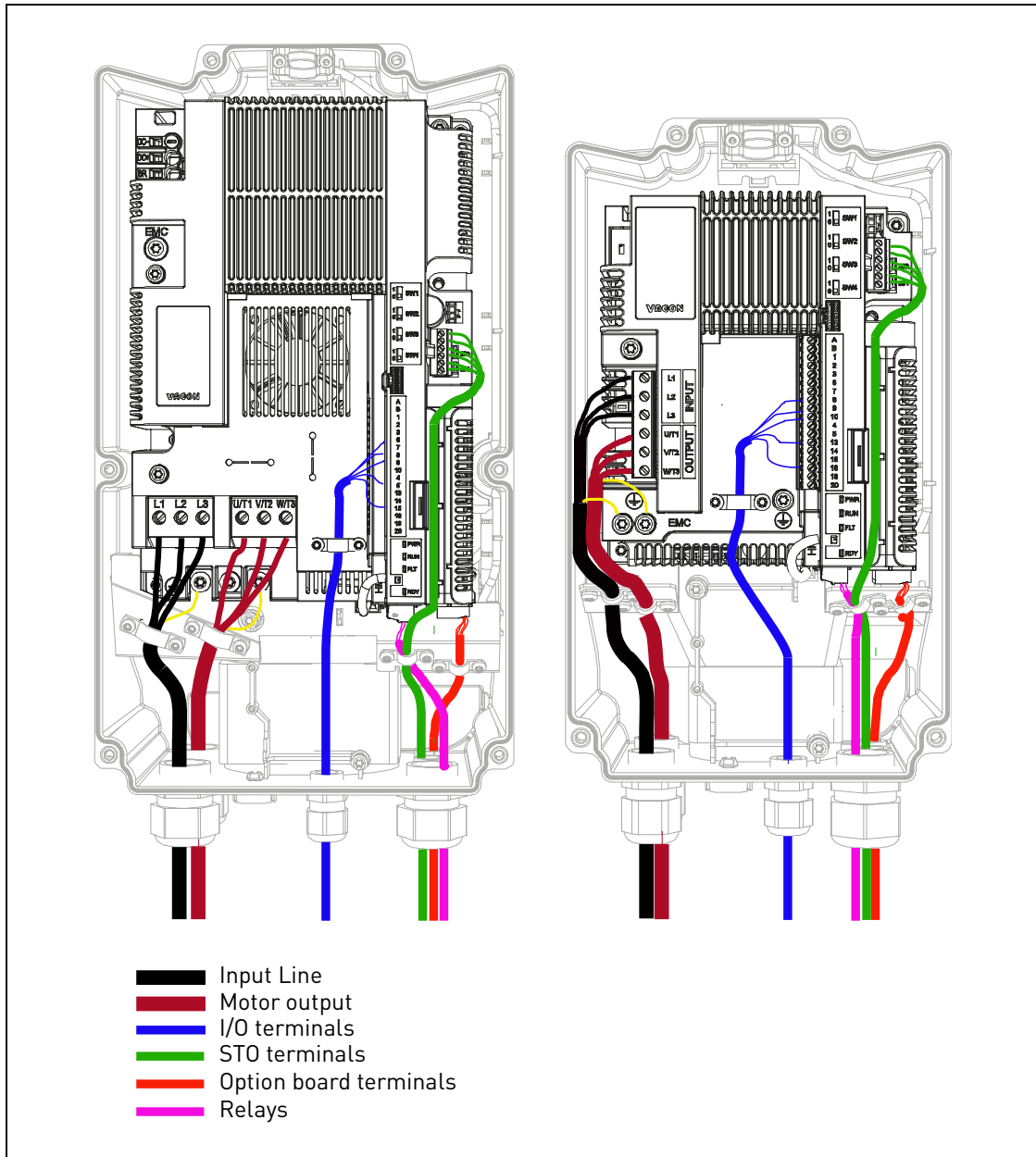

Figure 27. Wiring example with three-phase versions.

5. CONTROL UNIT

5.1 OPENING THE DRIVES

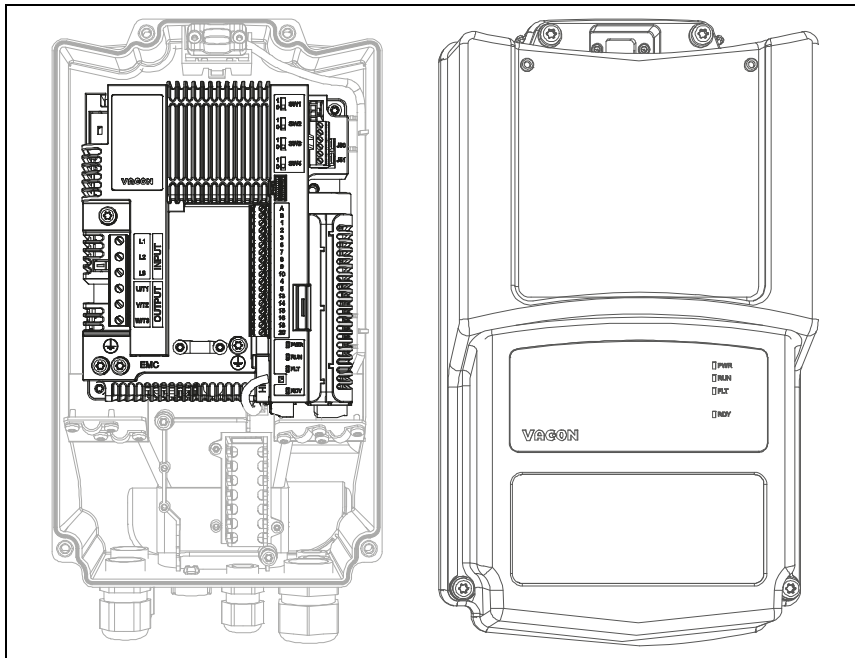

Figure 28. Open front cover of the drive: control unit MU2 (three-phase version).

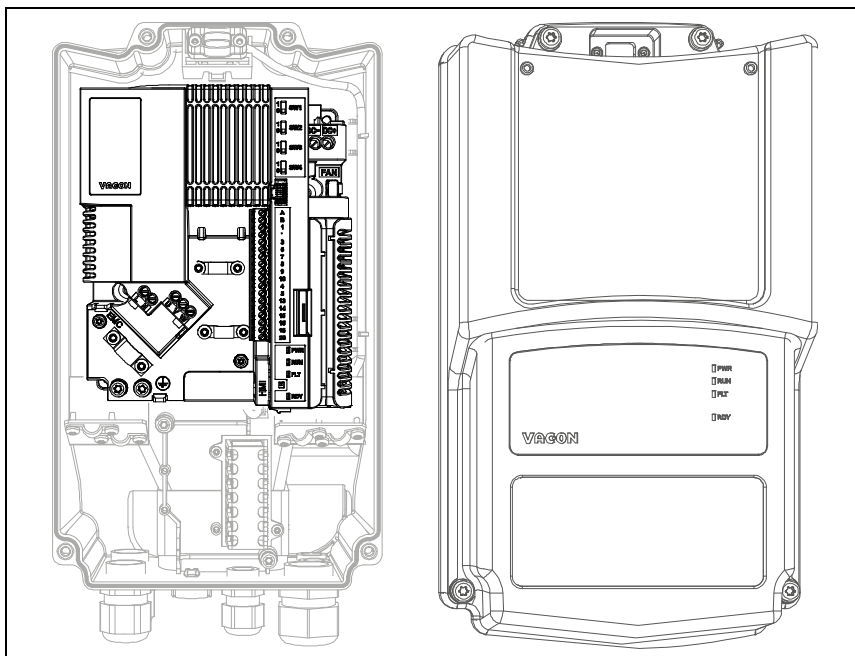

Figure 29. Open front cover of the drive: control unit MU2 (single-phase version).

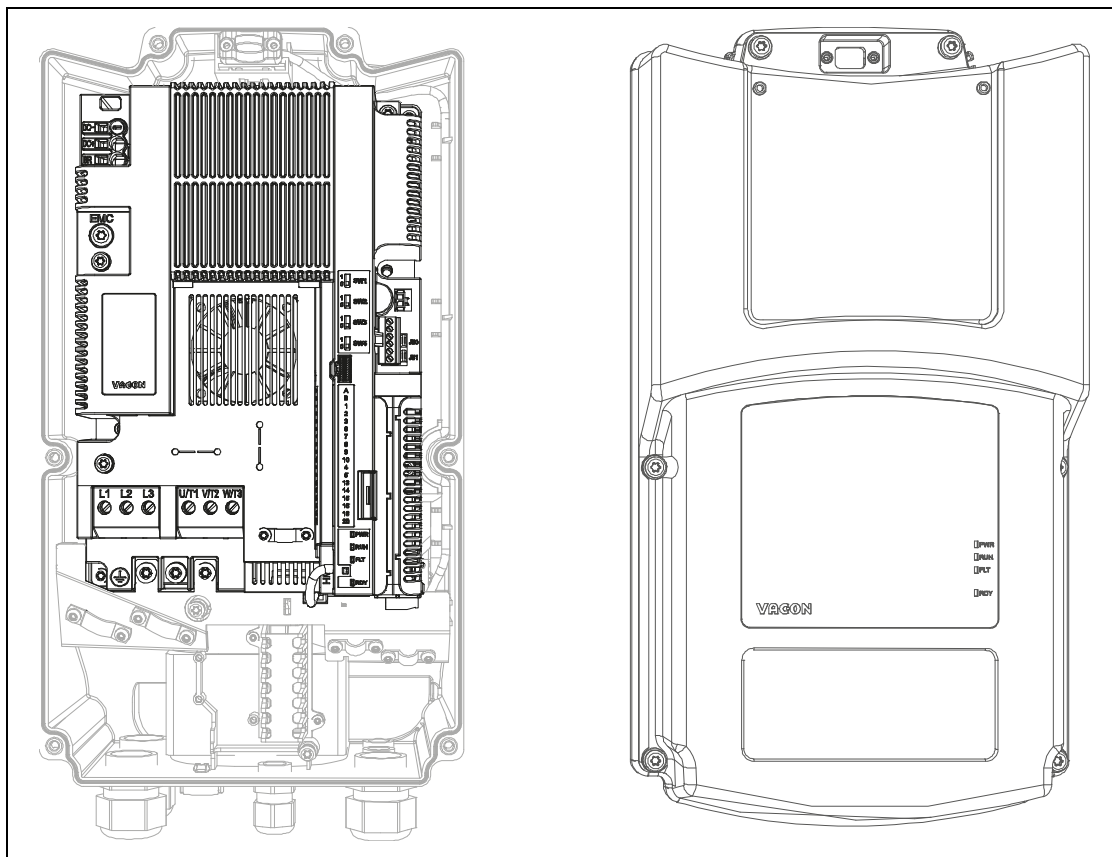

Figure 30. Open front cover of the drive: control unit MU3.

5.2 CONTROL UNITS MU2 AND MU3

The control unit of the AC drive consists of the control board and additional boards (option boards) connected to the slot connectors of the control board. The locations of boards, terminals and switches are presented in Figure 31, Figure 32 and Figure 33.

| Number | Meaning |
|--------|---|
| 1 | Control terminals A-20 |
| 2 | STO terminals (only in three-phase version) |
| 3 | Relay terminals |
| 4 | Option board terminals |
| 5 | STO Jumpers (only in three-phase version) |
| 6 | DIP switches |
| 7 | Status LEDs |
| 8 | HMI connector (RJ45 keypad connector)* |
| 9 | Optional brake resistor terminals |
| 10 | Supply voltage connector for external fan |
| 11 | Control terminals A-20 echo connector |
| 12 | HMI echo connector (keypad connector) |
| 13 | DC-bus terminals |

Table 19. Locations of components in control unit



* The HMI connector is only to connect the keypad and not for Ethernet communication.

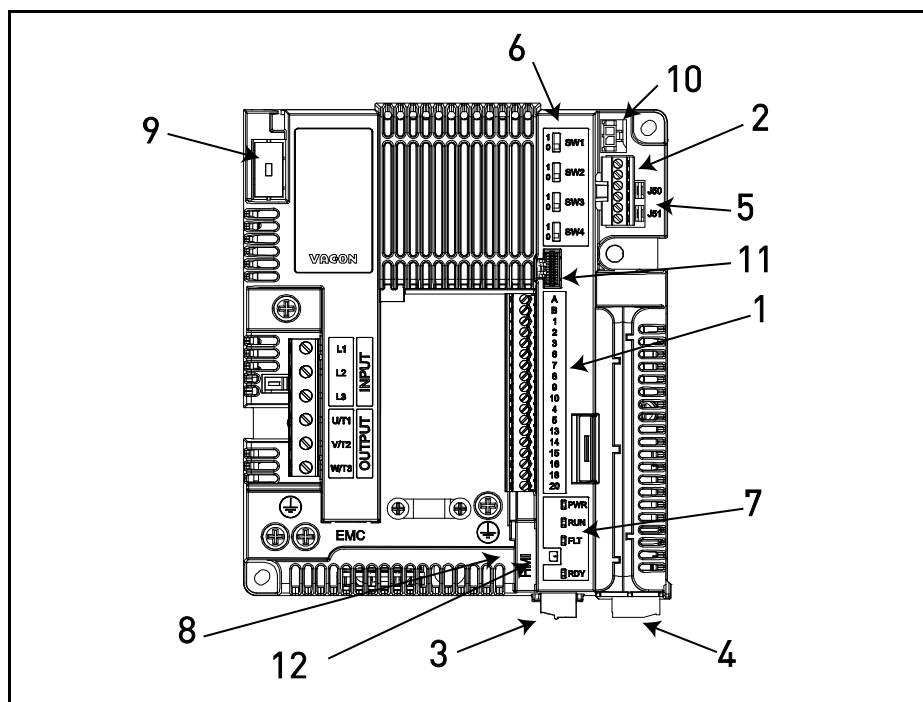

Figure 31. Locations of the components in control unit of MU2(three-phase version).

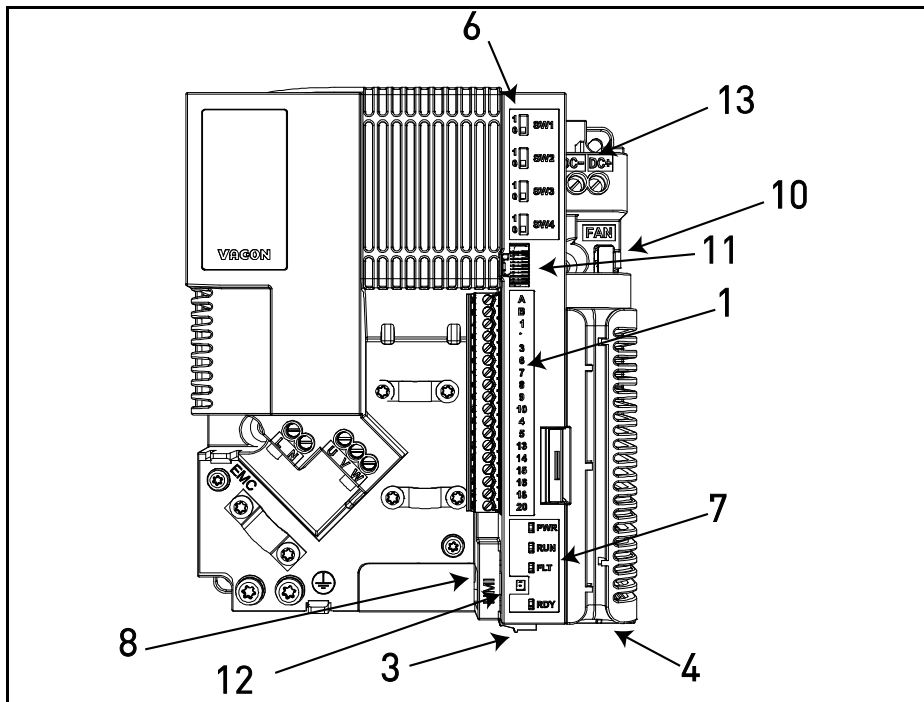

Figure 32. Locations of the components in control unit of MU2 (single-phase version).

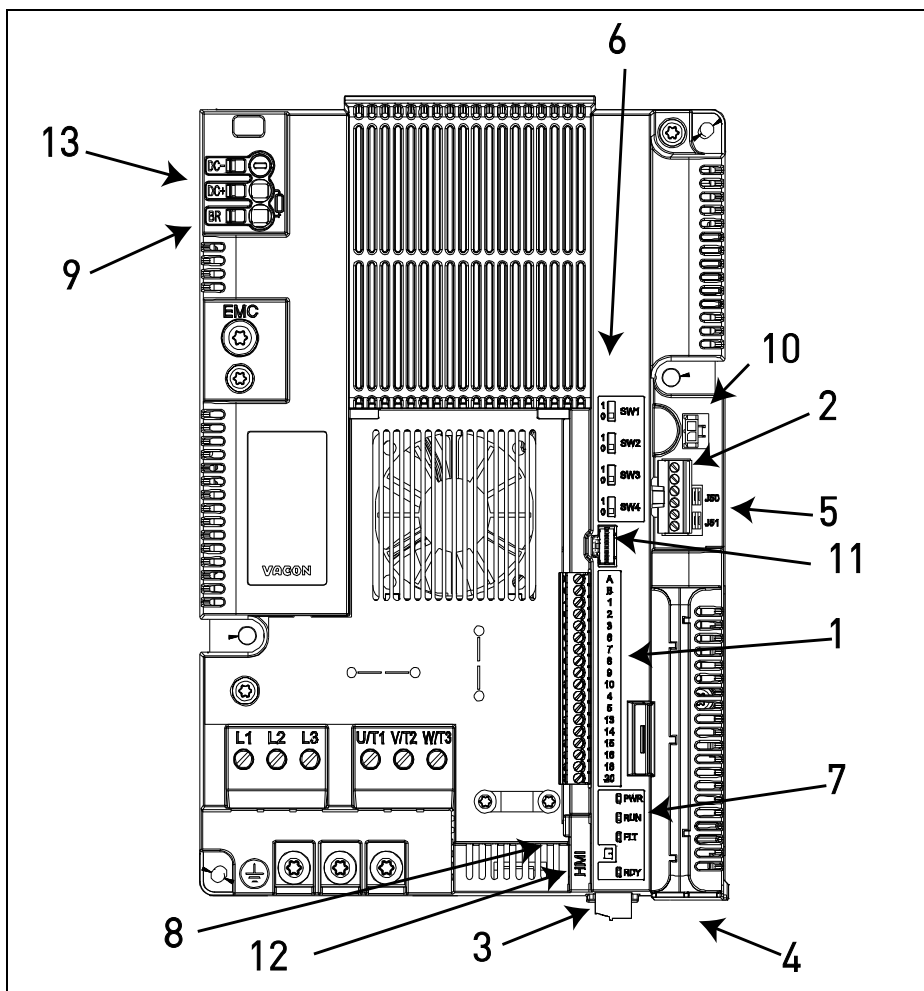

Figure 33. Location of the components in the control unit of MU3.

When delivered from the factory, the control unit of the AC drive contains the standard controlling interface - the control terminals of the control board and the relay board - unless otherwise specifically ordered. In the following pages you will find the arrangement of the control I/O and the relay terminals, the general wiring diagram and the control signal descriptions.

The control board can be powered externally (+24VDC \pm 10%, 1000mA) by connecting the external power source between terminal #6 and GND, see chapter 5.3.2. This voltage is sufficient for parameter setting and for keeping the control unit active. Note however that the values of the measurements of the main circuit (e.g. DC-link voltage, unit temperature) are not available when the mains is not connected.

5.3 CONTROL UNIT CABLING

The principal terminal block placement is shown in Figure 34 below. The control board is equipped with 18 fixed control I/O terminals and the relay board with 5. Additionally, the terminals for the Safe Torque Off (STO) function (see chapter 9) can be seen in the picture below. All signal descriptions are also given in Table 21.

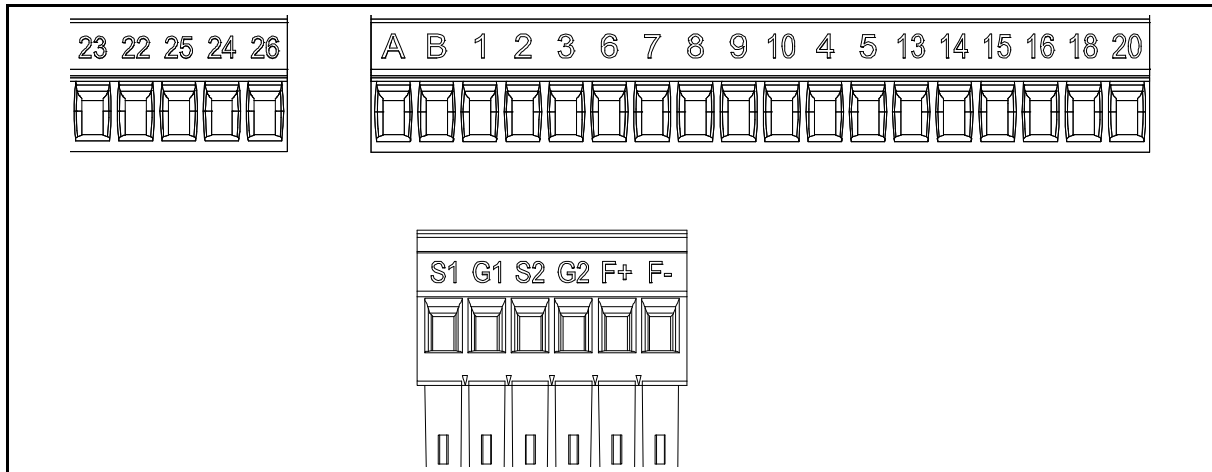

Figure 34. Control terminals.

5.3.1 CONTROL CABLE SIZING

The control cables shall be at least 0.14 mm² screened multi core cables, see Table 13 and Table 14. The maximum terminal wire size for the I/O terminals is 1.5 mm².

Find the tightening torques of the I/O (control and relays) and STO terminals in the Table 20 below.

| Terminal screw | Tightening torque | |
|--|----------------------|----------------------|
| | Nm | lb-in. |
| I/O terminals and STO terminals (screw M2) | 0.22 min 0.25 max | 1.94 min 2.21 max |

Table 20. Control cable tightening torques.

5.3.2 STANDARD I/O TERMINALS

The terminals of the *Standard I/O* and the *Relays* are described below. For more information on connections, see chapter 7.3.1.

The terminals shown on shadowed background are assigned for signals with optional functions selectable with DIP switches. For more information, see chapter 5.3.7.

Table 21. Control I/O terminal signals and connection example.

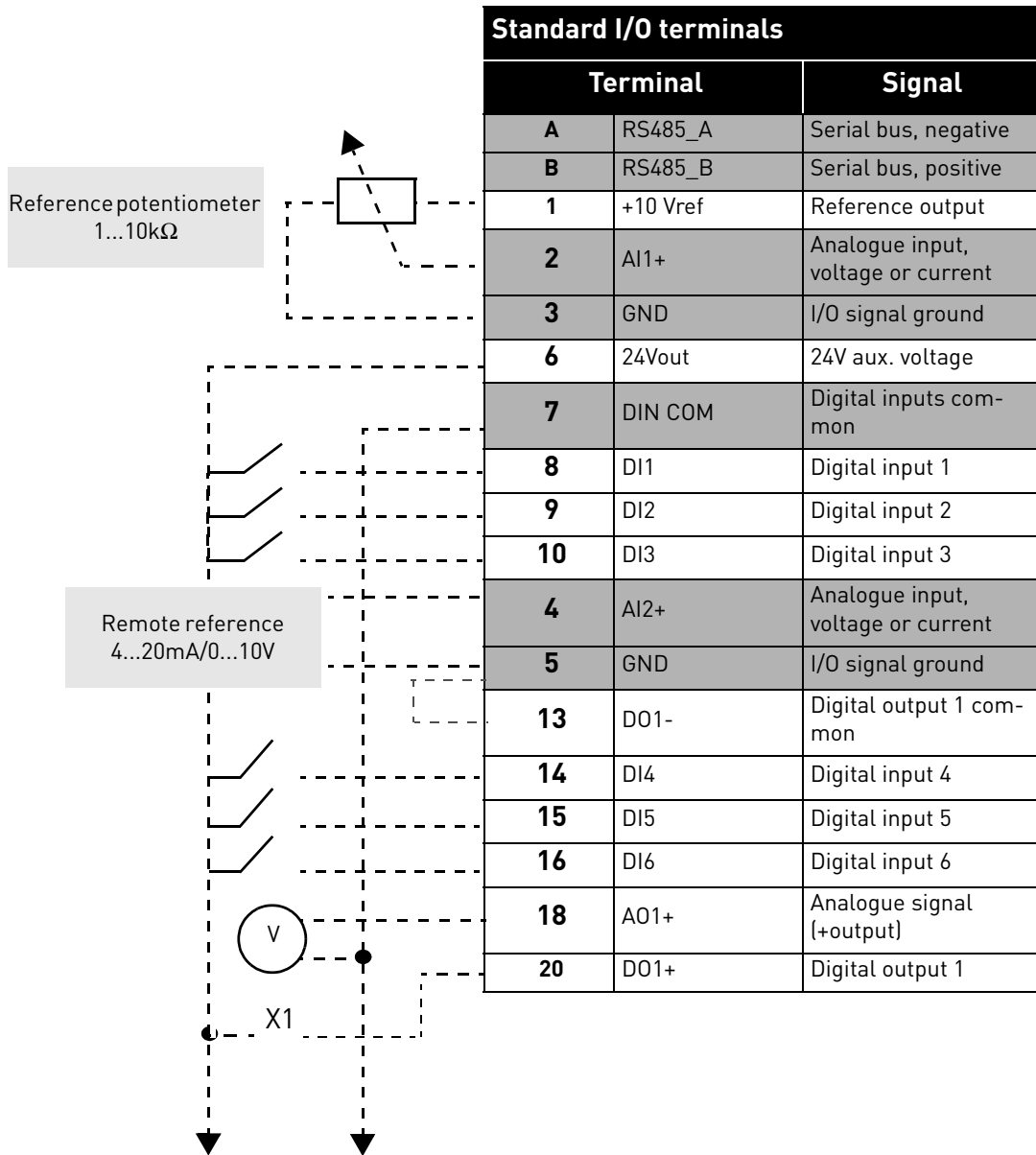

5.3.3 RELAY TERMINALS

Table 22. I/O terminal signals for relays and connection example.

| Relays terminals | | |
|------------------|-------|--------------------|
| Terminal | | Signal |
| 22 | R01/2 | Relay output 1 |
| 23 | R01/3 | |
| 24 | R02/1 | Relay output 2 |
| 25 | R02/2 | |
| 26 | R02/3 | |

5.3.4 SAFE TORQUE OFF (STO) TERMINALS

For more information on the functionalities of the Safe Torque Off (STO), see chapter 9. This function is available only in the three-phase version.

Table 23. I/O terminal signals for the STO functions.

| Safe Torque Off terminals | |
|---------------------------|---|
| Terminal | Signal |
| S1 | Isolated digital input 1 (interchangeable polarity); +24V ±20% 10...15mA |
| G1 | |
| S2 | Isolated digital input 2 (interchangeable polarity); +24V ±20% 10...15mA |
| G2 | |
| F+ | Isolated feedback (CAUTION! Polarity to be respected); +24V ±20% |
| F- | Isolated feedback (CAUTION! Polarity to be respected); GND |

5.3.5 DESCRIPTION OF ADDITIONAL ECHO CONNECTORS

In this paragraph you will find the description of the additional echo connector for the I/O terminals.

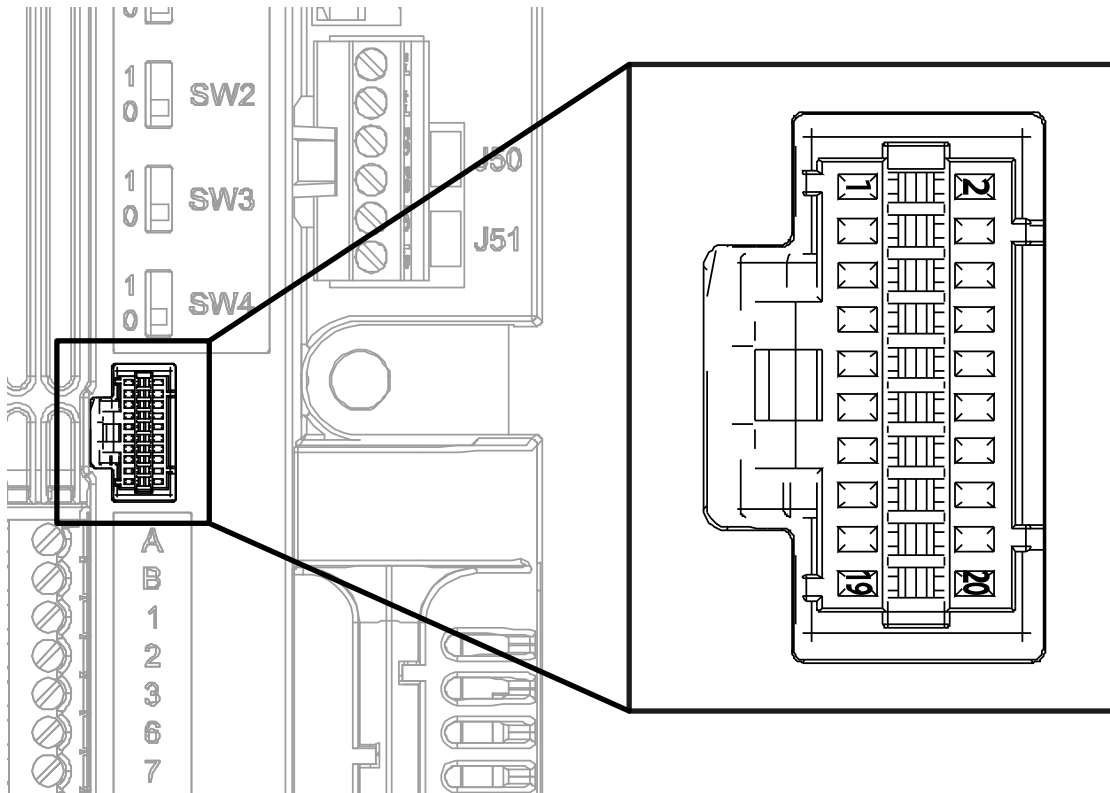

Figure 35. The I/O remote echo connector mounted on the control board.

In Figure 35 the view of Molex[®] connector for the I/O terminals is shown. In the control unit the position of this connector is numbered with 11 as shown in Figure 31, Figure 32 and Figure 33. The type of this connector is Pico-Clasp[™] Wire-to Board PCB Header, Dual Row, Right Angle. The code by Molex[®] is: 501571-2007.

It mates with Pico-Clasp[™] Wire-to Board Receptacle Housing (crimp housing), Dual Row, 20 Circuits. The code by Molex[®] is: 501189-2010. See Figure 36.

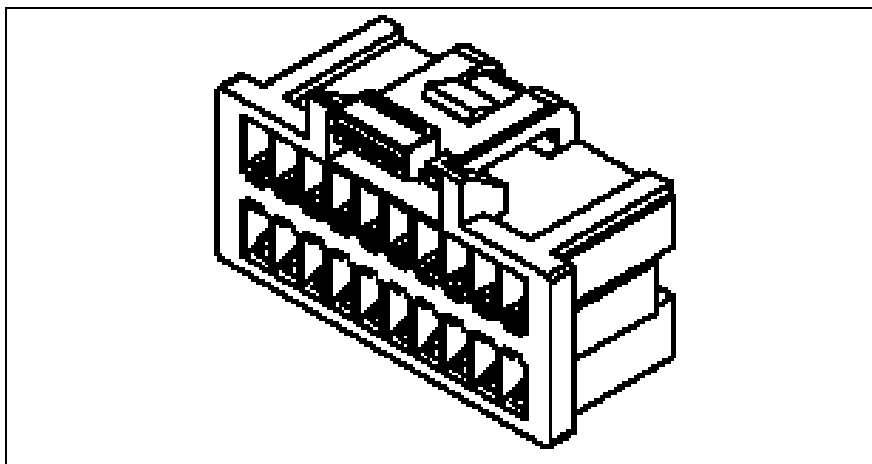

Figure 36. Receptacle housing for I/O remote echo connector.

To connect I/Os to the control unit through echo terminals this connector has to be used. In the following table, the correspondence between the pins of this connector and the VACON® 20 X terminals is shown.

| Pin number | Signal | Description |
|------------|---------|-----------------------------|
| 1 | RS485_B | Serial bus, positive |
| 2 | DI2 | Digital input 2 |
| 3 | RS485_A | Serial bus, negative |
| 4 | DI3 | Digital input 3 |
| 5 | NC | not connected |
| 6 | AI2+ | |
| 7 | NC | not connected |
| 8 | GND | |
| 9 | +10Vref | |
| 10 | DO1- | common for digital output 1 |
| 11 | AI1+ | |
| 12 | DI4 | Digital input 4 |
| 13 | GND | |
| 14 | DI5 | Digital input 5 |
| 15 | 24Vout | |
| 16 | DI6 | Digital input 6 |
| 17 | DIN COM | |
| 18 | AO1+ | Analogue output 1 |
| 19 | DI1 | Digital input 1 |
| 20 | DO1+ | Digital output 1 |

Table 24. I/O remote connector description.

5.3.6 LED HANDLING

As VACON® 20 X is often without the keypad, on the plastic cover of the drive there are 4 status LEDs. See the picture below.

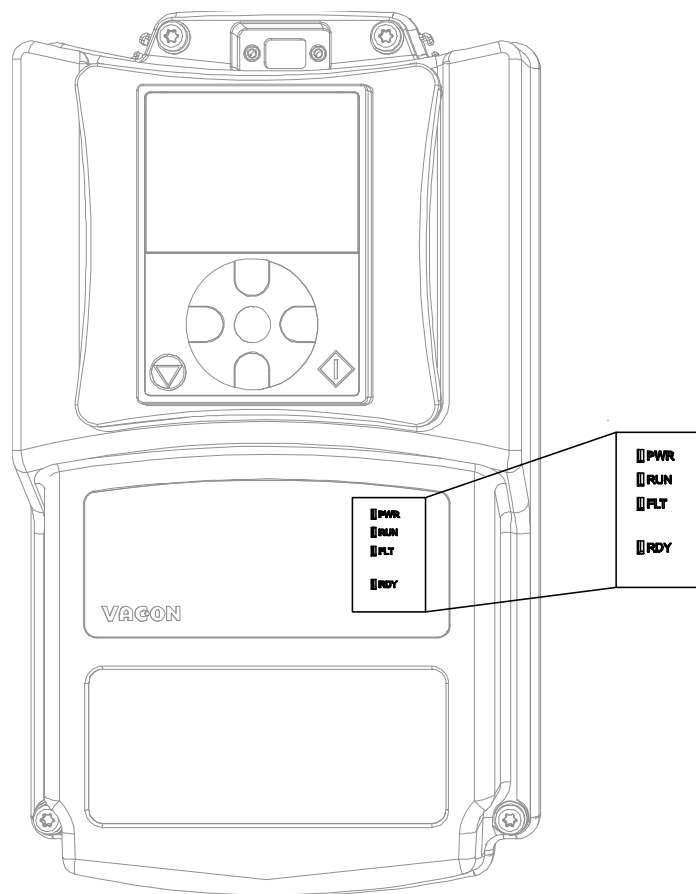

Figure 37. LED position on the MU2 cover.

Led "PWR" (orange led) means the drive is supplied by mains.

Led "RUN" (green led) means the drive is running.

Led "FLT" (red led) means the drive is experiencing a fault.

Led "RDY" (orange led) means the drive is ready and no fault is present. When a Warning is active, the led starts blinking.

5.3.7 SELECTION OF TERMINAL FUNCTIONS WITH DIP SWITCHES

The VACON® 20 X drive embodies four so-called *switches* that allow for two functional selections each. The shadowed terminals in Table 21 can be functionally modified with the dip switches.

The switches have two positions: 0 and 1. See Figure 38 to locate the switches and make appropriate selections for your requirements.

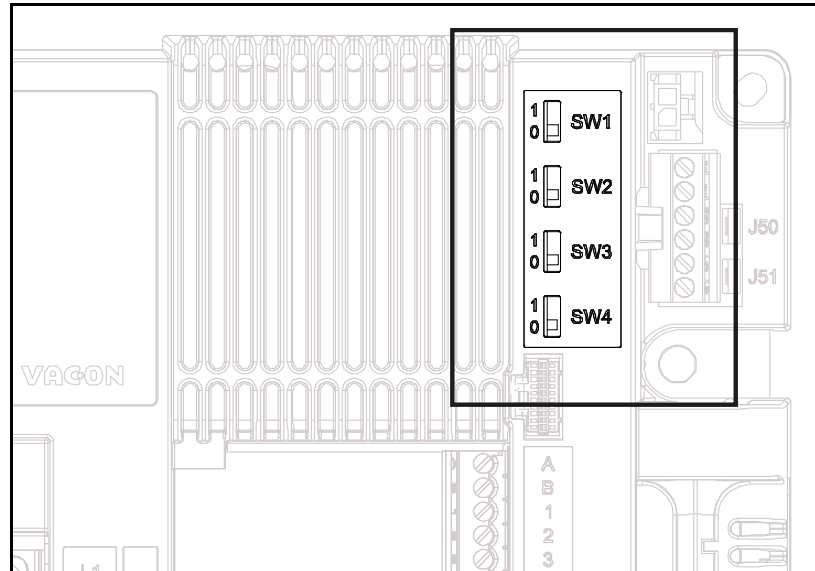

Figure 38. Dip switches on the control unit.

5.3.7.1 Switch SW1

The digital inputs (terminals 8-10 and 14-16) on the standard I/O board can be **isolated** from ground by setting the *dip switch SW1* to position '1'. See Figure 38. Locate the switch and set it in the desired position. The switch in the position "0" means that the common of digital input have been connected to the ground. The default position is "0".

5.3.7.2 Switches SW2 and SW3

Analogue inputs can be used as either current inputs or voltage inputs. The signal type is selected with two switches on the control board.

The switch SW2 is related to analogue input AI1. In position "1" the analogue input AI1 works in voltage mode. In position "0" the analogue input works in current mode. The default position for SW2 is "1".

The voltage range is 0...10V and the current is 0/4.....20 mA.

The switch SW3 is related to analogue input AI2. In the position "1" the analogue input AI2 works in voltage mode. In the position "0" the analogue input works in current mode. The default position for SW3 is "0".

The voltage range is 0...10V and the current is 0/4.....20 mA.

5.3.7.3 Switch SW4

The switch SW4 is related to the RS485 connection. It's used for bus termination. The bus termination must be set to the first and to the last device on the network. The switch SW4 in position "0" means that termination resistance is connected and the termination of the bus has been set. If the Vacon 20 X is the last device on the net, this switch must be set to "0" position. The default position for SW4 is "0".

5.4 FIELDBUS CONNECTION

Modbus is a communication protocol developed by Modicon systems. In other words, it is a way of sending information between electronic devices. The device requesting the information is called the Modbus Master and the devices supplying information are Modbus Slaves. In a standard Modbus network, there is one Master and up to 247 Slaves, each with a unique Slave Address from 1 to 247. The Master can also write information to the Slaves. Modbus is typically used to transmit signals from instrumentation and control devices back to a main controller or data gathering system.

The Modbus communication interface is built around messages. The format of these Modbus messages is independent of the type of physical interface used. The same protocol can be used regardless of the connection type. Thanks to this, Modbus allows for the easy upgrade of the hardware structure of an industrial network, without the need for significant changes in the software. A device can also communicate with several Modbus nodes at once, although they are connected with different interface types, without the need to use a different protocol for every connection.

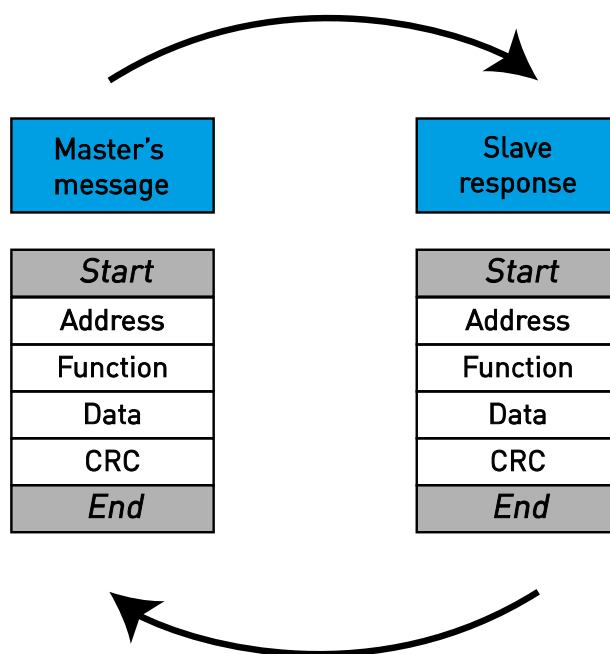

Figure 39. Basic structure of Modbus frame.

On simple interfaces such as RS485, the Modbus messages are sent in plain form over the network. In this case the network is dedicated to Modbus.

Each Modbus message has the same structure. Four basic elements are present in each message. The sequence of these elements is the same for all messages, to make it easy to parse the content of the Modbus message. A conversation is always started by a master in the Modbus network. A Modbus master sends a message and—depending on the contents of the message— a slave takes action and responds to it. There can be more masters in a Modbus network. The address in the message header is used to define which device should respond to a message. All other nodes on the Modbus network ignore the message if the address field doesn't match their own address.

5.4.1 MODBUS RTU PROTOCOL

| | | |
|---------------------------------------|----------------------|---|
| Connections and communications | Interface | RS-485 |
| | Data transfer method | RS-485 MS/TP, half-duplex |
| | Transfer cable | STP (shielded twisted pair), type Belden 9841 or similar |
| | Connector | 2.5 mm ² |
| | Electrical isolation | Functional |
| | Modbus RTU | As described in "Modicon Modbus Protocol Reference Guide" |
| | Baud rate | 300, 600, 1200, 2400, 4800, 9600, 19200, 38400 and 57600 baud |
| | Addresses | 1 to 247 |

Table 25.

VACON® 20 X drive is equipped with Modbus support as standard. The AC drive can be connected to fieldbus through RS485. The connection for RS485 is on the standard I/O (terminals A and B). See Figure 40.

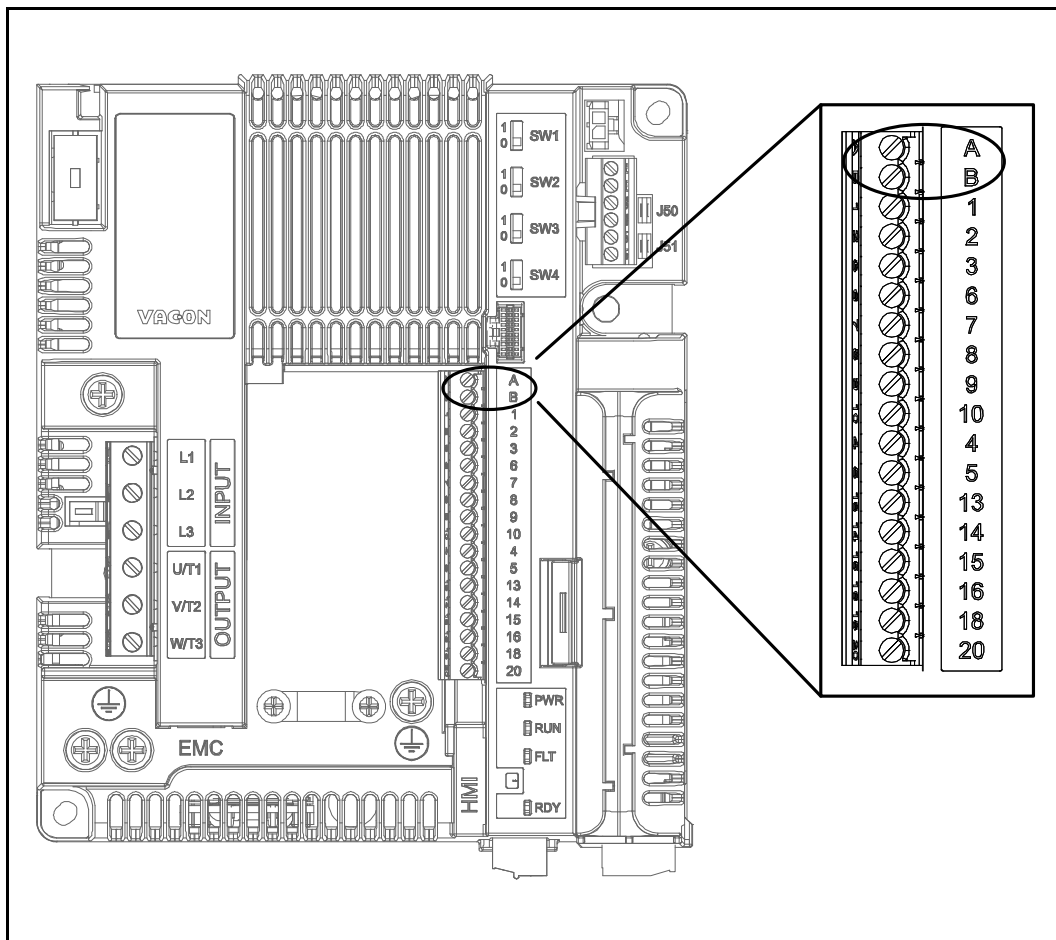
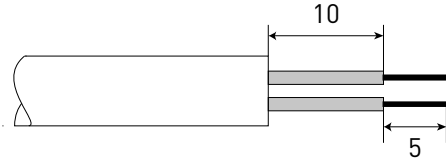
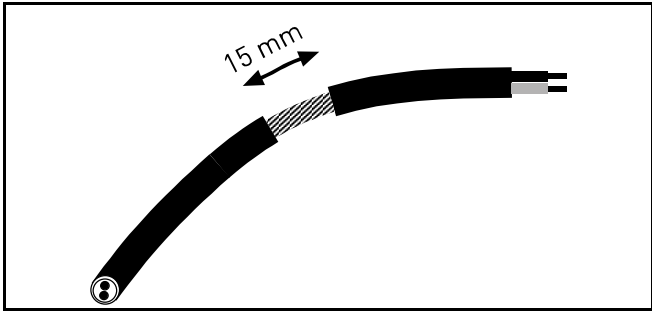
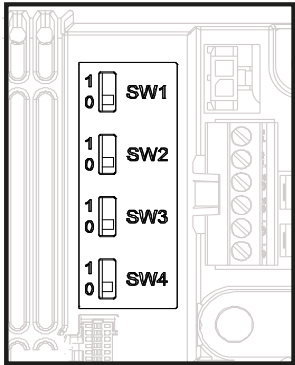

Figure 40. Position of the RS485 terminals on the I/O standard terminal connector(MU2 control unit example).

5.4.2 PREPARATION FOR USE THROUGH RS485

| | |
|-----------------|--|
| <p>1</p> | <p>Strip about 15 mm of the RS485 cable (see specification on Table 25) and cut off the grey cable shield. Remember to do this for both bus cables (except for the last device).</p> <p>Leave no more than 10 mm of the cable outside the terminal block and strip the cables at about 5 mm to fit in the terminals. See picture below.</p>  <p>Also strip the cable now at such a distance from the terminal that you can fix it to the frame with the grounding clamp. Strip the cable at a maximum length of 15 mm. Do not strip the aluminium cable shield!</p>  |
| <p>2</p> | <p>Then connect the cable to its appropriate terminals on Vacon20 X AC drive standard terminal block, terminals A and B (A = negative, B = positive).</p> |
| <p>3</p> | <p>Using the cable clamp included in the supply of the drive, ground the shield of the RS485 cable to the frame of the AC drive.</p> |
| <p>4</p> | <p>If VACON® 20 X drive is the last device on the bus, the bus termination must be set. Locate the switches to the right of the control terminals (see Figure 38) and turn the SW4 switch to position "0". Biasing is built in the termination resistor.</p>  |
| <p>5</p> | <p>NOTE: When planning the cable runs, remember to keep the distance between the fieldbus cable and the motor cable at a minimum of 30 cm.</p> |
| <p>6</p> | <p>The bus termination must be set for the first and the last device of the fieldbus line. We recommend that the first device terminated is the Master device.</p> |

6. COMMISSIONING

Before commissioning, note the following directions and warnings:



Internal components and circuit boards of VACON[®] 20 X drive (except for the galvanically isolated I/O terminals) are live when it is connected to the mains potential. **Coming into contact with this voltage is extremely dangerous and may cause death or severe injury.**



The motor terminals **U, V, W** and the brake resistor terminals **are live** when VACON[®] 20 X drive is connected to the mains, **even if the motor is not running.**



The control I/O-terminals are isolated from the mains potential. However, the **relay outputs may have a dangerous control voltage** present even when VACON[®] 20 X drive is disconnected from the mains.



Do not make any connections to or from the frequency converter when it is connected to the mains.



After disconnecting the AC drive from the mains, **wait** until the indicators on the cover go out. Wait an additional 30 seconds before doing any work on the connections of VACON[®] 20 X Drive. Do not open the unit before this time has expired. After expiration of this time, use a measuring equipment to absolutely ensure that no voltage is present. **Always ensure absence of voltage before starting any electrical work!**

6.1 COMMISSIONING OF THE DRIVE

Read carefully the safety instructions in Chapter 1 and above and follow them.

After the installation:

| | |
|--------------------------|---|
| <input type="checkbox"/> | Check that both the frequency converter and the motor are grounded. |
| <input type="checkbox"/> | Check that the mains and motor cables comply with the requirements given in chapter 4.1.1. |
| <input type="checkbox"/> | Check that the control cables are located as far as possible from the power cables, see chapter 4.4. |
| <input type="checkbox"/> | Check that the shields of the shielded cables are connected to protective earth marked with  . |
| <input type="checkbox"/> | Check the tightening torques of all terminals |
| <input type="checkbox"/> | Check that the wires do not touch the electrical components of the drive. |
| <input type="checkbox"/> | Check that the common inputs of digital input groups are connected to +24V or ground of the I/O terminal |
| <input type="checkbox"/> | Check the quality and quantity of cooling air |
| <input type="checkbox"/> | Check the inside of the frequency converter for condensation. |
| <input type="checkbox"/> | Check that all Start/Stop switches connected to the I/O terminals are in the Stop-position. |
| <input type="checkbox"/> | Before connecting the frequency converter to mains: Check mounting and condition of all fuses and other protective devices. |

6.2 CHANGING EMC PROTECTION CLASS

If your supply network is an IT (impedance-grounded) system but your AC drive is EMC-protected according to class C1 or C2 you need to modify the EMC protection of the AC drive to EMC-level T (C4). This is done as described below:



Warning! Do not perform any modifications on the AC drive when it is connected to mains.

6.2.1 CHANGING EMC PROTECTION CLASS - MU2 THREE-PHASE VERSION

1

Remove the three screws on the EMC plate from the unit.

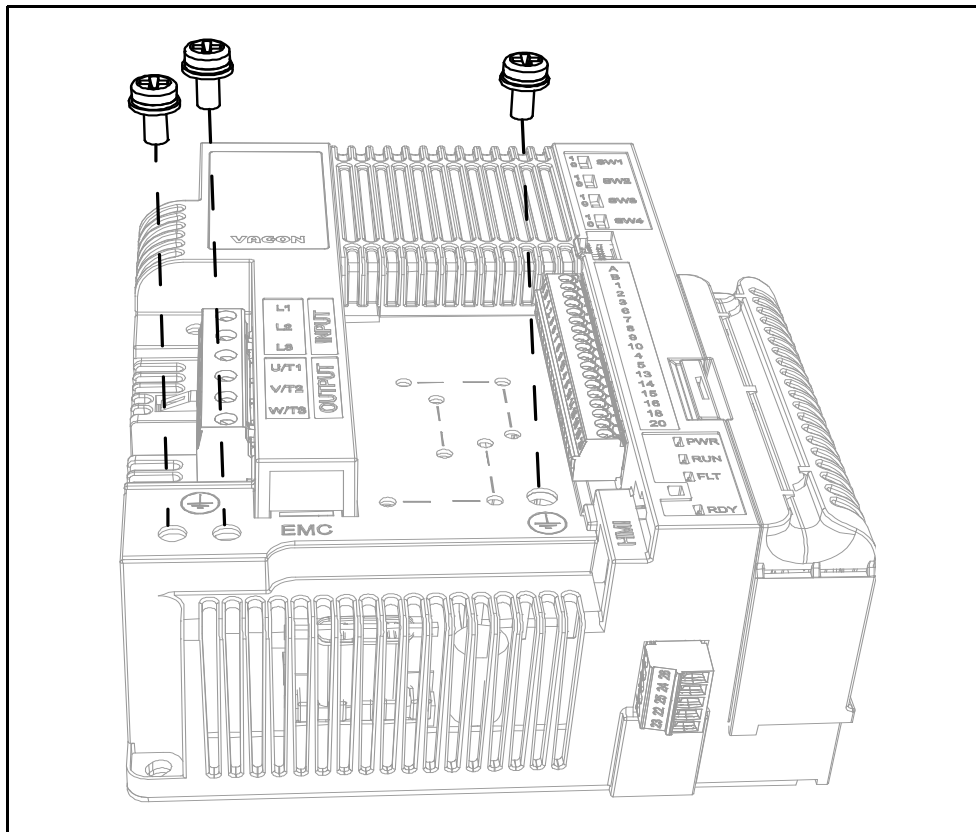

Figure 41. Changing of the EMC class in MU2 control unit.

2 Remove the EMC plate from the control unit. Then lift the plate with pliers to disconnect the EMC plate from the ground. See Figure 42.
Then reconnect the EMC plate to the unit.

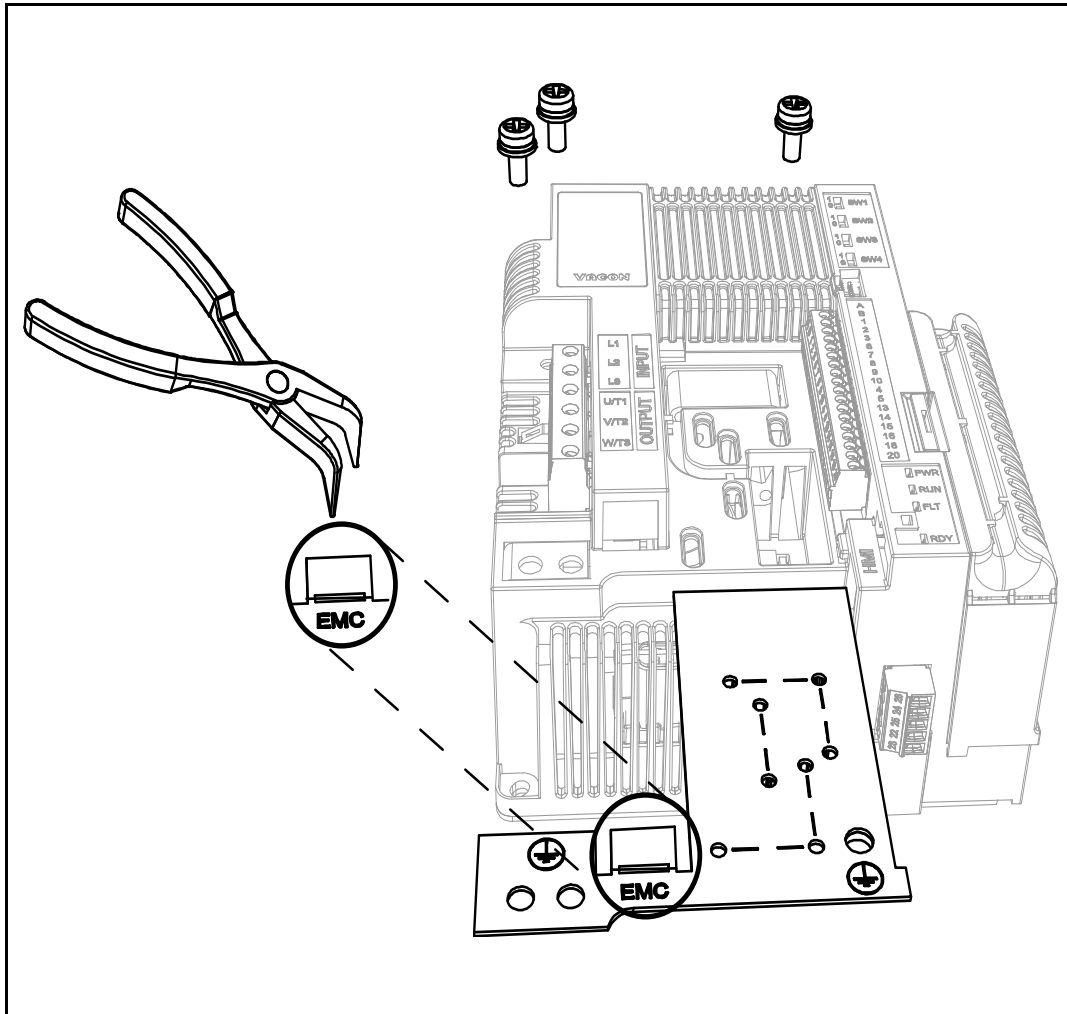

Figure 42. Changing of the EMC class in MU2 control unit.

6.2.2 CHANGING EMC PROTECTION CLASS - MU2 SINGLE-PHASE VERSION

1

Remove the EMC screw as shown in the Figure 43.

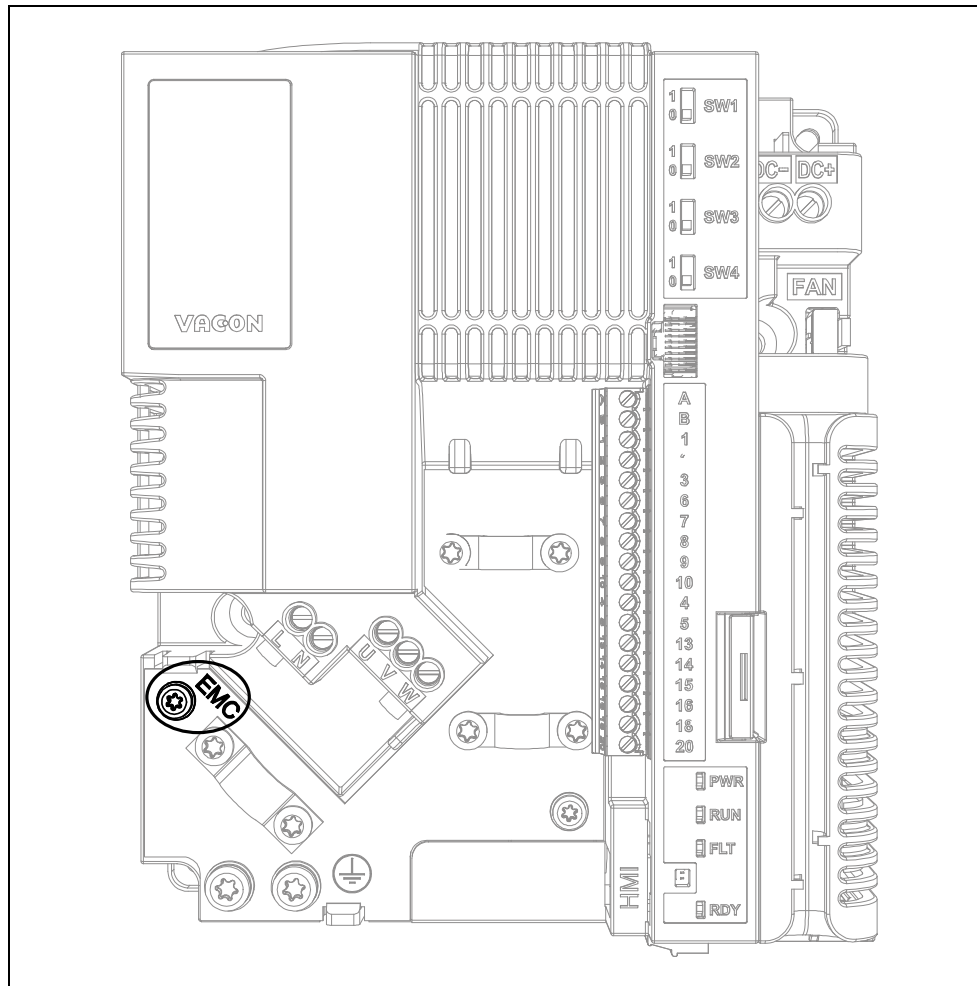

Figure 43. Changing the EMC class in the MU2 (single-phase version).

6.2.3 CHANGING EMC PROTECTION CLASS - MU3

- | | |
|----------|---|
| 1 | Remove the EMC screw as shown in the Figure 44. |
|----------|---|

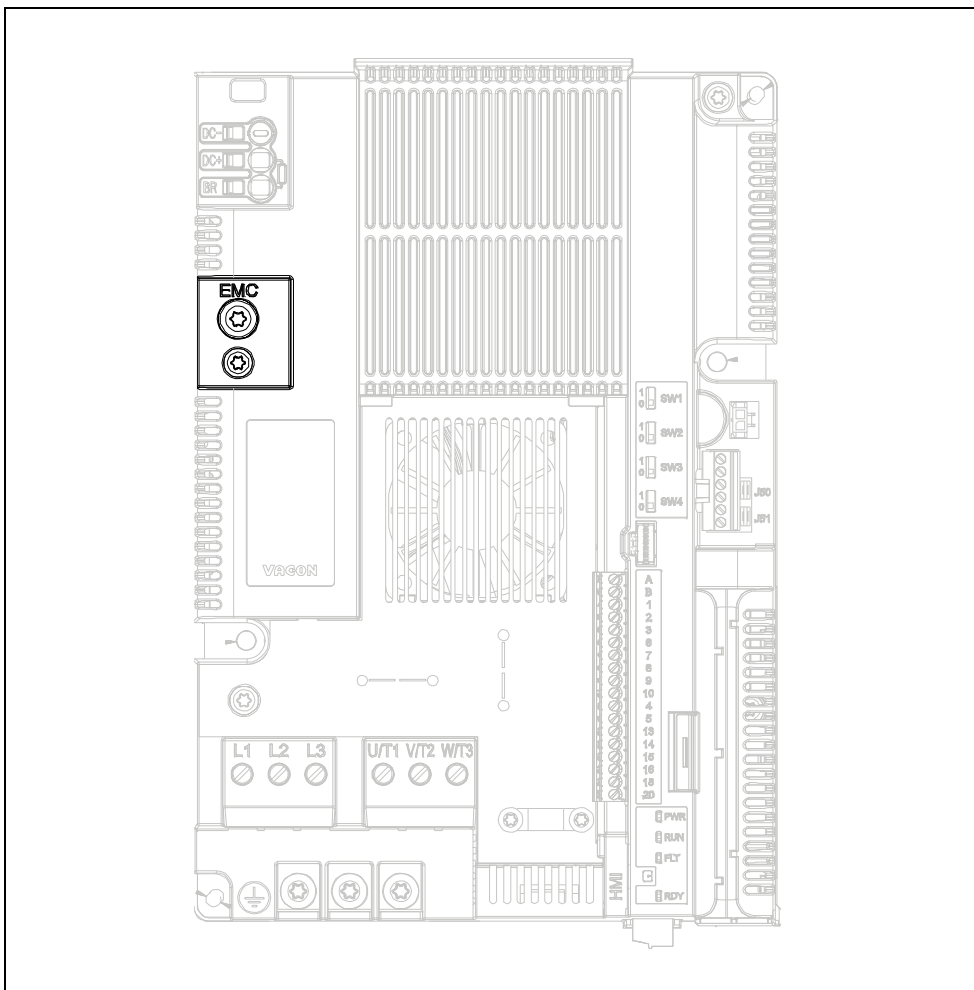

Figure 44. Changing the EMC class in the MU3 control unit.

| | |
|--|---|
| | <p>CAUTION! Before connecting the AC drive to mains make sure that the EMC protection class settings of the drive are appropriately made.</p> |
| | <p>NOTE! After having performed the change write 'EMC level modified' on the sticker included in the VACON® 20 X delivery (see below) and note the date. Unless already done, attach the sticker close to the name plate of the AC drive.</p> <div style="border: 1px solid black; padding: 5px; margin: 10px auto; width: fit-content;"> <p style="text-align: center;">Product modified</p> <p style="text-align: right;">Date:</p> <p style="text-align: right;">Date:</p> <p style="text-align: center;">EMC-level modified C1->C4 Date:DDMMYY </p> </div> |

6.3 RUNNING THE MOTOR

MOTOR RUN CHECK LIST



Before starting the motor, check that the motor is **mounted properly** and ensure that the machine connected to the motor allows the motor to be started.



Set the maximum motor speed (frequency) according to the motor and the machine connected to it.



Before reversing the motor make sure that this can be done safely.



Make sure that no power correction capacitors are connected to the motor cable.



Make sure that the motor terminals are not connected to mains potential.

6.3.1 CABLE AND MOTOR INSULATION CHECKS

1. Motor cable insulation checks
Disconnect the motor cable from terminals U, V and W of the AC drive and from the motor. Measure the insulation resistance of the motor cable between each phase conductor as well as between each phase conductor and the protective ground conductor. The insulation resistance must be $>1\text{M}\Omega$ at ambient temperature of 20°C .
2. Mains cable insulation checks
Disconnect the mains cable from terminals L1, L2 and L3 of the AC drive and from the mains. Measure the insulation resistance of the mains cable between each phase conductor as well as between each phase conductor and the protective ground conductor. The insulation resistance must be $>1\text{M}\Omega$ at ambient temperature of 20°C .
3. Motor insulation checks
Disconnect the motor cable from the motor and open the bridging connections in the motor connection box. Measure the insulation resistance of each motor winding. The measurement voltage must equal at least the motor nominal voltage but not exceed 1000 V. The insulation resistance must be $>1\text{M}\Omega$ at ambient temperature of 20°C .

6.4 MAINTENANCE

In normal conditions, the AC drive is maintenance-free. However, regular maintenance is recommended to ensure trouble-free operation and longevity of the drive. We recommend the table below is followed for maintenance intervals.

| Maintenance interval | Maintenance action |
|---|--|
| Regularly and according to general maintenance interval | <ul style="list-style-type: none"> • Check tightening torques of terminals |
| 6...24 months (depending on environment) | <ul style="list-style-type: none"> • Check input and output terminals and control I/O terminals. • Check for corrosion on terminals and other surfaces • Check the heatsink for dust and clean if necessary |
| 6...10 years | <ul style="list-style-type: none"> • Change main fan |
| 12...24 months | <ul style="list-style-type: none"> • Charge capacitors, only after long storage times or long down times without supply: contact your nearest Vacon service center. |

Table 26.

7. TECHNICAL DATA

7.1 AC DRIVE POWER RATINGS

7.1.1 MAINS VOLTAGE 3AC 208-240V

| Mains Voltage 3AC 208-240V, 50/60 Hz | | | | | | | |
|--------------------------------------|----------------|-------------------|------------------------------------|--------------------------|-------------------|-------------------|------------|
| | Converter type | Input current [A] | Loadability | | | Motor shaft power | |
| | | | Rated continuous current I_N [A] | 50% overload current [A] | Max current I_S | 230V | 240V |
| | | | | | | [kW] | [HP] |
| MU2 | 0004 | 4.3 | 3.7 | 5.6 | 7.4 | 0.75 | 1.0 |
| | 0005 | 6.8 | 4.8 | 7.2 | 9.6 | 1.1 | 1.5 |
| | 0007 | 8.4 | 7.0 | 10.5 | 14.0 | 1.5 | 2.0 |
| MU3 | 0011 | 13.4 | 11.0 | 16.5 | 22.0 | 2.2 | 3.0 |
| | 0012 | 14.2 | 12.5 | 18.8 | 25.0 | 3.0 | 4.0 |
| | 0017 | 20.6 | 17.5 | 26.3 | 35.0 | 4.0 | 5.0 |

Table 27. Power ratings of VACON® 20 X, supply voltage 208-240V.

NOTE: The rated currents in given ambient temperatures (in Table 27) are achieved only when the switching frequency is equal to or less than the factory default.

7.1.2 MAINS VOLTAGE 1AC 208-240V

| Mains Voltage 1AC 208-240V, 50/60 Hz | | | | | | | |
|--------------------------------------|----------------|-------------------|------------------------------------|--------------------------|-------------------|-------------------|------------|
| | Converter type | Input current [A] | Loadability | | | Motor shaft power | |
| | | | Rated continuous current I_N [A] | 50% overload current [A] | Max current I_S | 230V | 230V |
| | | | | | | [kW] | [HP] |
| MU2 | 0004 | 8.3 | 3.7 | 5.6 | 7.4 | 0.75 | 1.0 |
| | 0005 | 11.2 | 4.8 | 7.2 | 9.6 | 1.1 | 1.5 |
| | 0007 | 14.1 | 7.0 | 10.5 | 14.0 | 1.5 | 2.0 |

Table 28. Power ratings of VACON® 20 X, supply voltage 1AC 208-240V.

NOTE: The rated currents in given ambient temperatures (in Table 28) are achieved only when the switching frequency is equal to or less than the factory default.

7.1.3 MAINS VOLTAGE 3AC 380-480V

| Mains Voltage 3AC 380-480V, 50/60 Hz | | | | | | | |
|--------------------------------------|----------------|-------------------|------------------------------------|--------------------------|-------------------|-------------------|------|
| | Converter type | Input current [A] | Loadability | | | Motor shaft power | |
| | | | Rated continuous current I_N [A] | 50% overload current [A] | Max current I_S | 400V | 480V |
| | | | | | | [kW] | [HP] |
| MU2 | 0003 | 3.2 | 2.4 | 3.6 | 4.8 | 0.75 | 1.0 |
| | 0004 | 4.0 | 3.3 | 5.0 | 6.6 | 1.1 | 1.5 |
| | 0005 | 5.6 | 4.3 | 6.5 | 8.6 | 1.5 | 2.0 |
| | 0006 | 7.3 | 5.6 | 8.4 | 11.2 | 2.2 | 3.0 |
| | 0008 | 9.6 | 7.6 | 11.4 | 15.2 | 3.0 | 4.0 |
| MU3 | 0009 | 11.5 | 9.0 | 13.5 | 18.0 | 4.0 | 5.0 |
| | 0012 | 14.9 | 12.0 | 18.0 | 24.0 | 5.5 | 7.5 |
| | 0016 | 20 | 16.0 | 24.0 | 32.0 | 7.5 | 10.0 |

Table 29. Power ratings of VACON® 20 X, supply voltage 380-480V.

NOTE: The rated currents in given ambient temperatures (in Table 29) are achieved only when the switching frequency is equal to or less than the factory default.

7.1.4 DEFINITIONS OF OVERLOADABILITY

Overloadability =Following continuous operation at rated output current I_N , the converter supplies 150% * I_N for 1 min, followed by a period of at least 9 min at I_N or below.

Example: If the duty cycle requires 150% rated current for 1 min in every 10 min, the remaining 9 min must be at rated current I_N or less.

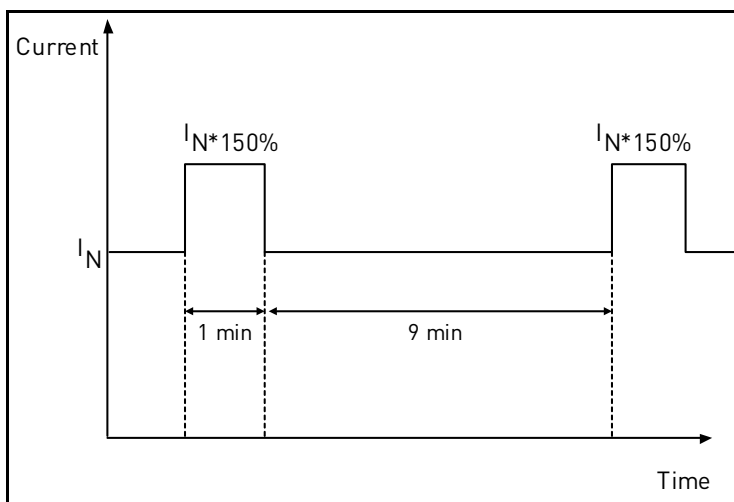

Figure 45. High overload.

7.2 BRAKE RESISTOR RATINGS

Make sure that the resistance is higher than the minimum resistance defined. The power handling capacity must be sufficient for the application. Brake chopper is available only in three-phase version.

Recommended minimum brake resistor values for Vacon 20 X AC drives:

| Mains Voltage 3AC 208-240 V, 50/60 Hz | | |
|---------------------------------------|------|--------------------------------------|
| Frame | Type | Minimum Resistance recommended [Ohm] |
| MU2 | 0004 | 50 |
| | 0005 | 50 |
| | 0007 | 50 |
| MU3 | 0011 | 25 |
| | 0012 | 25 |
| | 0017 | 25 |

Table 30. Brake resistor ratings, 208-240V.

| Mains Voltage 3AC 380-480 V, 50/60 Hz | | |
|---------------------------------------|------|--------------------------------------|
| Frame | Type | Minimum Resistance recommended [Ohm] |
| MU2 | 0003 | 100 |
| | 0004 | 100 |
| | 0005 | 100 |
| | 0006 | 100 |
| | 0008 | 100 |
| MU3 | 0009 | 50 |
| | 0012 | 50 |
| | 0016 | 50 |

Table 31. Brake resistor ratings, 380-480V.

7.3 VACON[®] 20 X - TECHNICAL DATA

| | | |
|--------------------------------|---|---|
| Mains connection | Input voltage U_{in} | 3AC 208...240V 1AC 208...240V 3AC 380...480V |
| | Input voltage tolerance | -15%...+10% continuously |
| | Input frequency | 50/60 Hz |
| | Input frequency tolerance | 45...66 Hz |
| | Protection class | I |
| | Connection to mains | Once per minute or less |
| | Starting delay | 4 s |
| | Supply network | IT and TN-networks (cannot be used with corner earthed networks) |
| | Short-circuit current | Maximum short-circuit current has to be <50kA |
| | DC connection | Available as standard in MU2 single-phase frames and MU3 |
| Motor connection | Output voltage | 3AC 0... U_{in} |
| | Rated output current | I_N : Ambient temperature max. +40°C. See Table 27 and Table 29. |
| | Overload output current | $1.5 \times I_N$ (1 min/10 min) |
| | Starting current | I_S for 2 s every 20 s ($I_S = 2.0 * I_N$) |
| | Output frequency | 0...320 Hz |
| | Frequency resolution | 0.01 Hz |
| | Protection class | I |
| | Motor characteristics | AC squirrel cage motors Permanent magnet motors |
| | Cable type | Screened motor cable |
| Cable maximum length | 30 m | |
| Control characteristics | Switching frequency | Programmable 2...16 kHz; Default 6 kHz. Automatic switching frequency derating in case of overheating |
| | Frequency reference: Analogue input Panel reference | Resolution $\pm 0.05\%$ (11-bit), accuracy $\pm 1\%$ Resolution 0.01 Hz |
| | Field weakening point | 8...320 Hz |
| | Acceleration time | 0.1...3000 sec |
| | Deceleration time | 0.1...3000 sec |
| | Braking | Brake chopper standard in all three-phase frames. External brake resistor optional. |
| Control connections | See Chapter 5. | |

| | | | |
|---|----------------------------------|---|--|
| Communication interface | Fieldbus | Standard: Serial communication (RS485/Modbus); Optional: CANopen; Profibus DP, Lonworks, DeviceNet, Profinet IO, Ethernet IP, Modbus TCP, EtherCAT, AS-interface | |
| | Status indicators | Drive status indicators (LED) on top side (POWER, RUN, FAULT, READY) | |
| Ambient conditions | Ambient operating temperature | -10°C...+40°C | |
| | Extended temperature range | up to 50°C with current derating (see chapter 1.8) | |
| | Storage temperature | -40°C...+70°C | |
| | Relative humidity | 0 to 100% RH. Good resistance to most acids, alkalis and oils. Contact factory for more details. | |
| | Pollution degree | PD2 used for PCB design. However the drive is suitable for outdoor use because of dust-tight enclosure to numeral 6 [acc. to IEC 60529] | |
| | Altitude | 100% load capacity (no derating) up to 1,000m; derating 1% / 100m at 1.000...3.000m | |
| | Degree of protection | IP66/Type 4X (IP65 when used with Simple Operator Panel +QDSH) | |
| | Stationary vibration: Sinusoidal | 3 Hz ≤ f ≤ 8.43 Hz: 7.5mm 8.43 Hz ≤ f ≤ 200 Hz: 2g (3M6 acc. to IEC 60721-3-3) | |
| | Shock/Bump: | 25g/6ms (3M6 acc. to IEC 60721-3-3) | |
| Directives | EMC | 2004/108/EC | |
| | Low Voltage | 2006/95/EC | |
| | RoHS | 2002/95/EC | |
| | WEEE | 2012/19/EC | |
| Standards | Immunity | EN61800-3: 2004 + A1: 2011, 1 st and 2 nd environment | |
| | Emissions | EN61800-3: 2004 + A1: 2011, | |
| | | 3-phase version | Category C2 as standard for conducted and radiated emissions |
| | | 1-phase version | Category C1 as standard for conducted emissions |
| | | | Category C2 as standard for radiated emissions. |
| The drive can be modified to category C4. | | | |
| Safety | EN 61800-5-1 | | |
| Production quality | ISO 9001 | | |

| | | |
|----------------------------------|--|---|
| Approvals | Functional Safety | TÜV - Tested |
| | Electrical Safety | TÜV - Tested |
| | EMC | TUV - Tested |
| | USA, Canada | cULus approval, file number E171278 |
| Declaration of Conformity | Korea | KC mark |
| | Australia | C-tick Declaration of Conformity |
| | Europe | EC Declaration of Conformity |
| Protections | Undervoltage trip limit | Depends on supply voltage (0,8775*supply voltage): Supply voltage 400 V: Trip limit 351 V Supply voltage 480 V: Trip limit 421 V Supply voltage 240 V: Trip limit 211 V |
| | Earth fault protection | Yes |
| | Mains supervision | Yes |
| | Motor phase supervision | Yes (not available in 1-phase version) |
| | Overcurrent protection | Yes |
| | Unit overtemperature protection | Yes |
| | Motor overload protection | Yes. These devices provide motor overload protection at 105% of full load amperes. |
| | Motor stall protection | Yes |
| | Motor underload protection | Yes |
| | Short-circuit protection of +24V and +10V reference voltages | Yes |
| Thermal motor protection | Yes (by PTC with option card) | |

Table 32. Vacon 20 X technical data.

7.3.1 TECHNICAL INFORMATION ON CONTROL CONNECTIONS

| Standard I/O | | |
|--------------|------------------------------------|---|
| Terminal | Signal | Technical information |
| A | RS485 | Differential receiver/transmitter |
| B | RS485 | Set bus termination with dip switches (see Chapter 5) |
| 1 | Reference output | +10V, ±5%; Maximum current 10 mA |
| 2 | Analogue input, voltage or current | Analogue input channel 1 0- +10V (Ri = 200 kΩ) 0/4-20 mA (Ri =250 Ω) Resolution 0.05%, accuracy ±1 % Selection V/mA with dip-switches (see Chapter 5). Default 0- +10V |
| 3 | I/O ground | Ground for reference and controls (connected internally to frame earth through 2MΩ) |
| 6 | 24V aux. voltage | +24V, ±10%, max volt. ripple < 100mVrms; max. 100 mA Short-circuit protected Can be used with an external power supply (with a current limiter or fuse protected) to supply the control unit and fieldbus for backup purposes. Dimensioning: max. 1000mA/control unit. |
| 7 | DIN COM | Common for digital inputs. Connected to GND with dip-switch SW1. See Chapter 5 |
| 8 | Digital input 1 | Positive or negative logic Ri = min. 4kΩ 15...30V = "1" 0...5V = "0" |
| 9 | Digital input 2 | |
| 10 | Digital input 3 | |
| 4 | Analogue input, voltage or current | Analogue input channel 2 0- +10V (Ri = 200 kΩ) 0/4-20 mA (Ri =250 Ω) Resolution 0.05%, accuracy ±1 % Selection V/mA with dip-switches (see Chapter 5). Default 0/4-20 mA |
| 5 | I/O ground | Ground for reference and controls (connected internally to frame earth through 2MΩ) |
| 13 | Digital output common | Common for digital output 1 (DO1-) |
| 14 | Digital input 4 | Positive or negative logic Ri = min. 4kΩ 15...30V = "1" 0...5V = "0" |
| 15 | Digital input 5 | |
| 16 | Digital input 6 | |
| 18 | Analogue signal (+output) | Analogue output channel 1, 0-10V (30mA max) Resolution 0.1%, accuracy ±2,5 % Short-circuited protected. |
| 20 | Digital Output 1 | Open Collector max 35V / 50mA (DO1+) |

Table 33. Technical information on standard I/O terminals.

| Relays | | |
|----------|------------------|---|
| Terminal | Signal | Technical information |
| 22 | Relay output 1 * | Switching capacity 250VAC/3A (only earthed network allowed) |
| 23 | | |
| 24 | Relay output 2* | Switching capacity NO 250VAC/5A NC 250VAC/3A (only earthed network allowed) |
| 25 | | |
| 26 | | |

* If 230VAC is used as control voltage from the output relays, the control circuitry must be powered with a separate isolation transformer to limit short circuit current and overvoltage spikes. This is to prevent welding on the relay contacts. Refer to standard EN 60204-1, section 7.2.9

Table 34. Technical information on Relays.

8. OPTIONS

8.1 VACON KEYPAD WITH SEVEN-SEGMENT DISPLAY

The text keypad is an option available for VACON® 20 X. The control keypad is the interface between the VACON® 20 X frequency converter and the user.

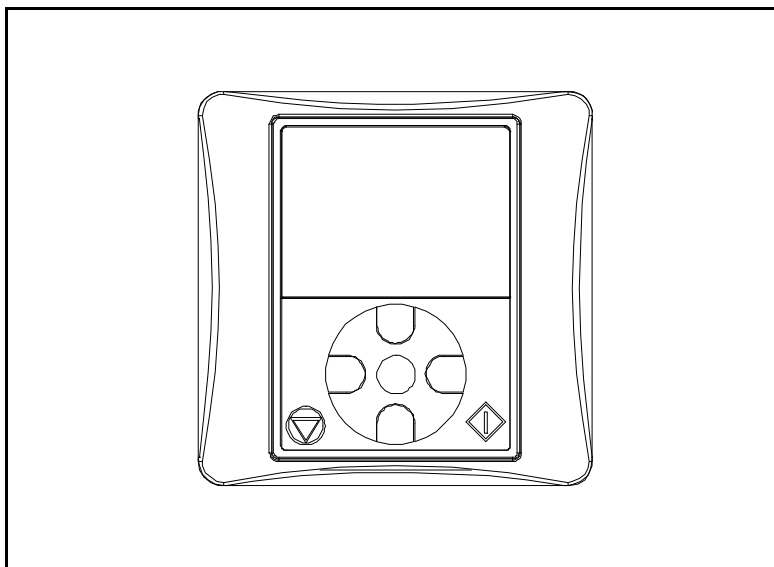

Figure 46. Text keypad.

| Order code | Description | Type of option |
|-----------------------|---|----------------|
| VACON-PAN-HMTX-MC06-X | Handheld/Magnetic fixing IP66 text keypad w/ cable, l=1m/39,37 inches | Loose option |

8.1.1 MOUNTING ONTO THE DRIVE

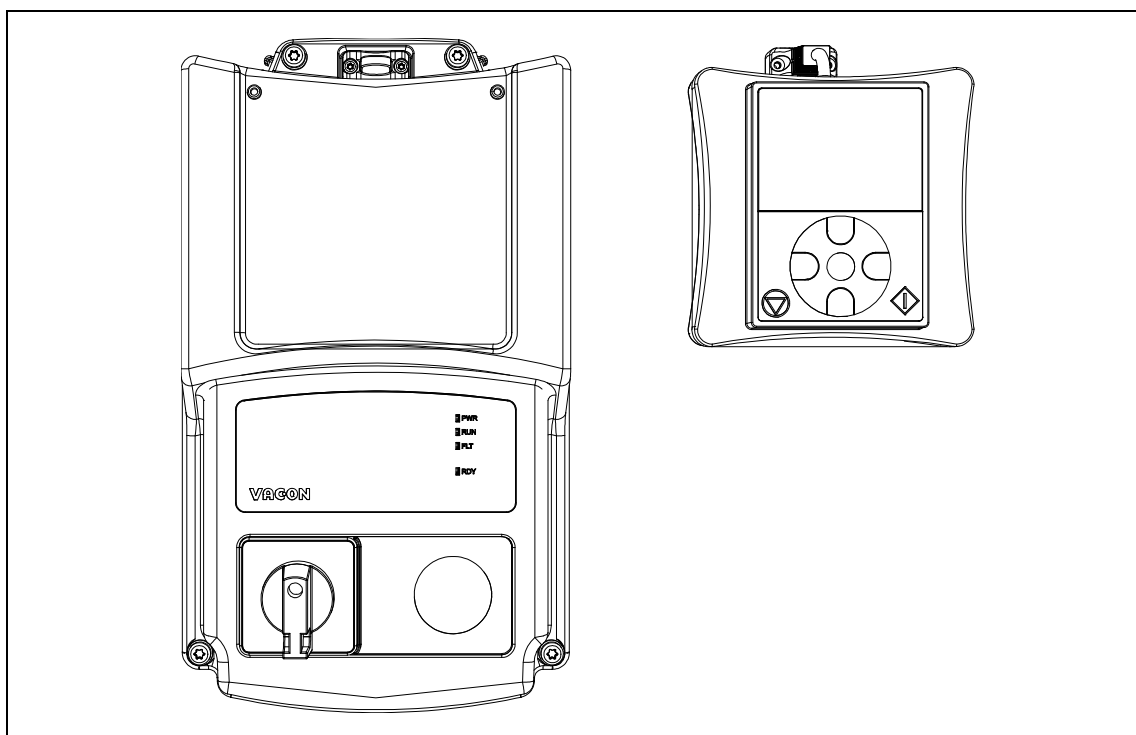

Figure 47. Drive and the optional keypad kit. The optional keypad kit includes: keypad and cable.

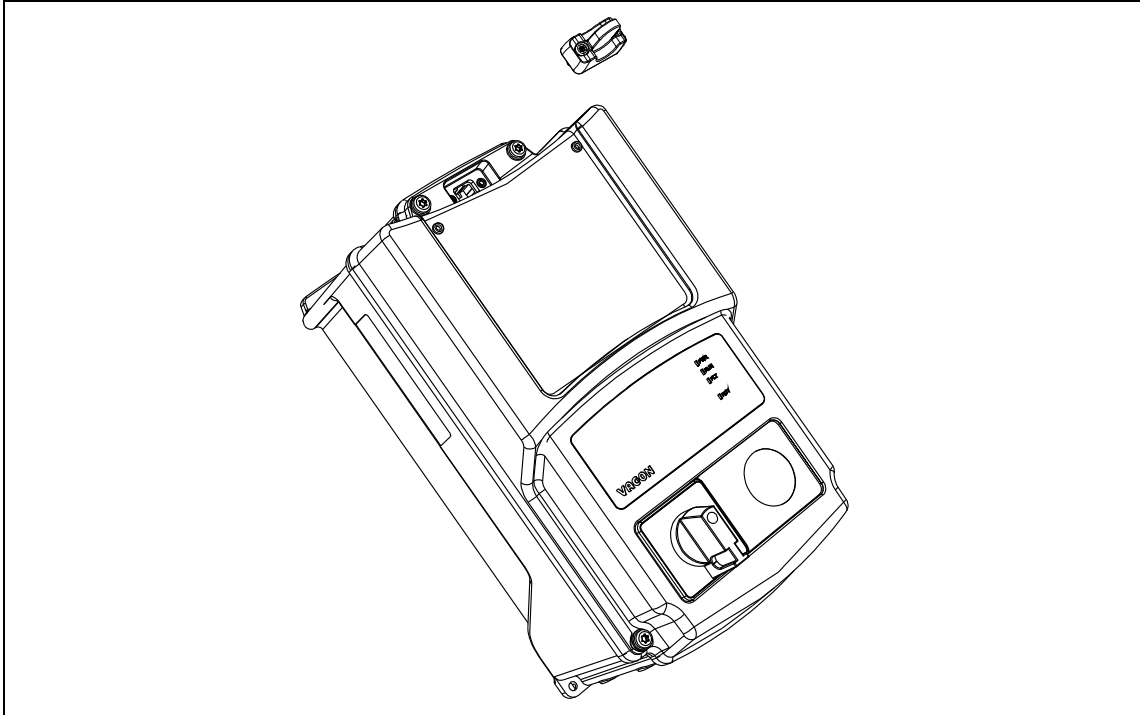

Figure 48. Disconnection of the HMI cap from the drive.

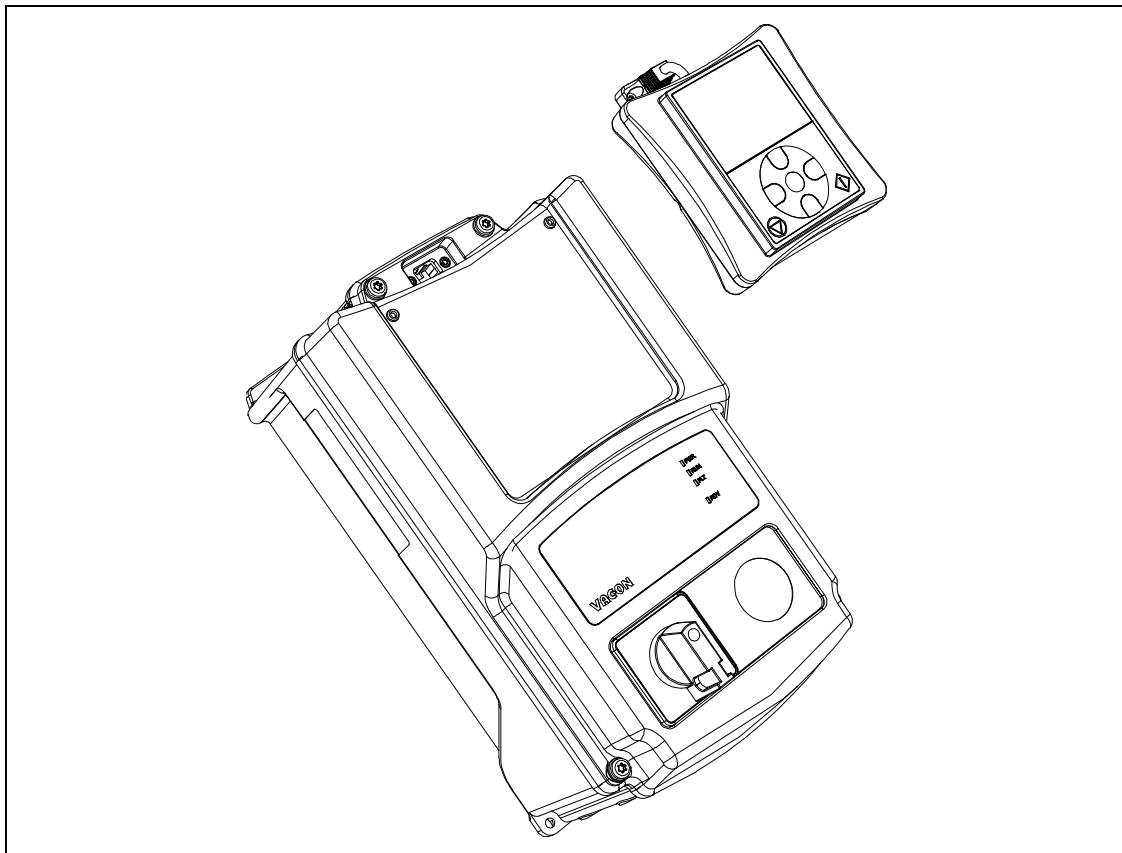

Figure 49. Mounting of the keypad.

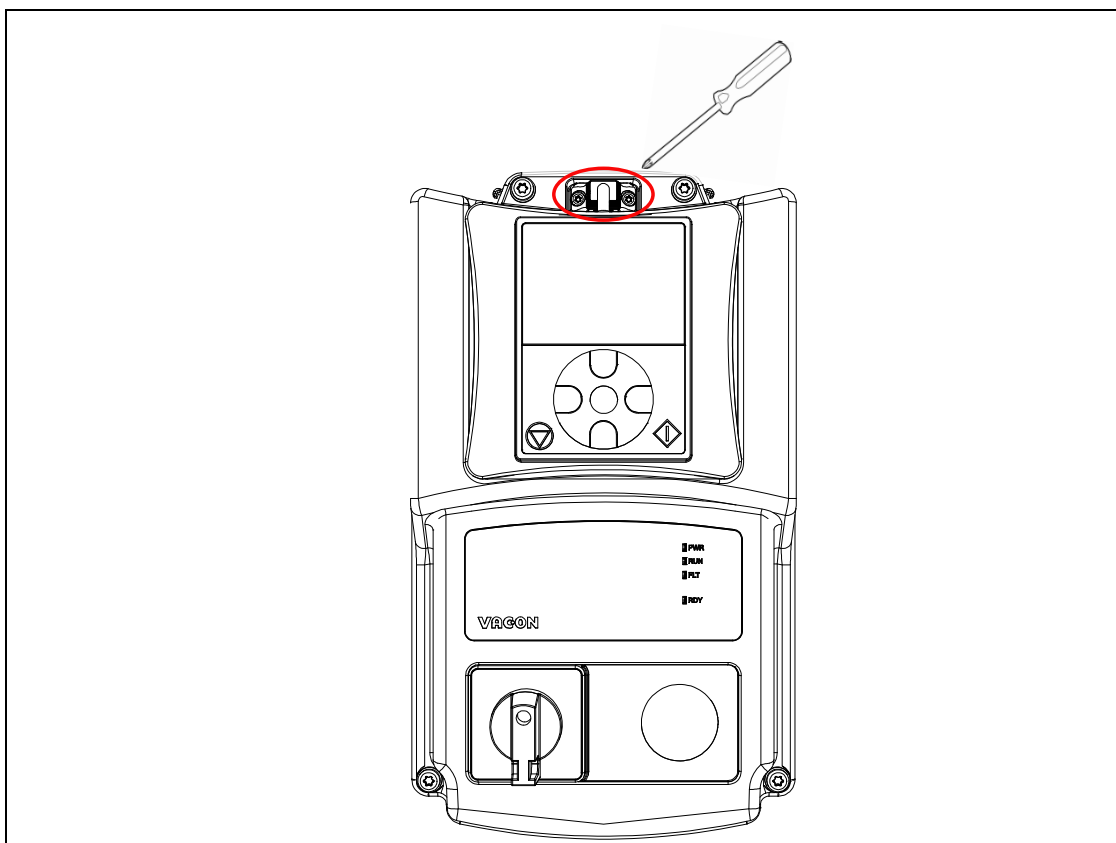

Figure 50. Tighten the two screws (maximum tightening torque 0.5 Nm) of the keypad cable to the enclosure of the drive. Keypad mounted onto the drive.

8.1.2 TEXT KEYPAD - BUTTONS

With the keypad it's possible to control the speed of the motor, to supervise the state of the drive and to set the frequency converter's parameters.

The button section of the text keypad is shown in the following picture.

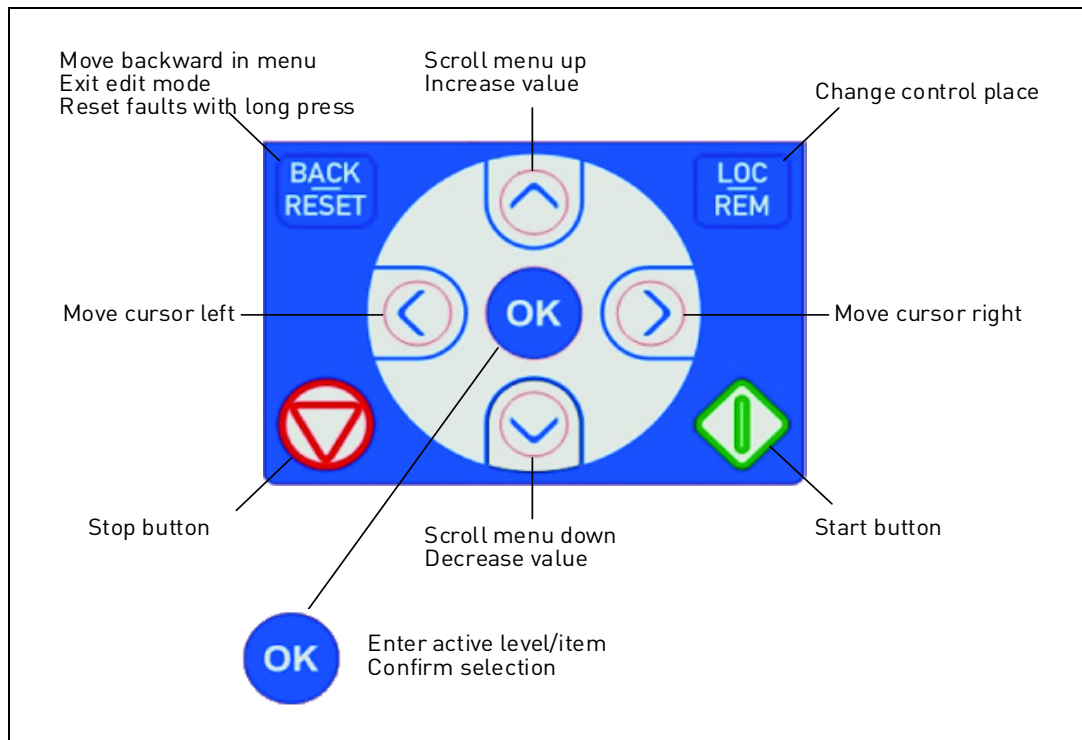

Figure 51. Keypad buttons.

8.2 TEXT KEYPAD

The keypad display indicates the status of the motor and the drive and any irregularities in motor or drive functions. On the display, the user can see the information about his present location in the menu structure and the item displayed.

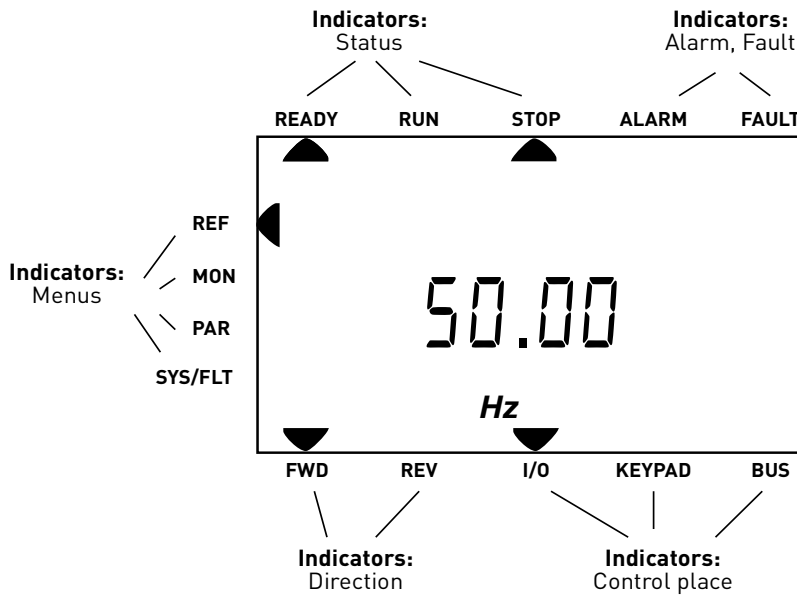

Figure 52. Keypad display.

8.3 MENU STRUCTURE

The data on the control keypad are arranged in menus. Use the Up and Down arrows to move between the menus. Enter the group/item by pressing the OK button and return to the former level by pressing the Back/Reset button. The arrows on the left of the display show the active menu. In Figure 52 the REF menu is active. The table below shows the structure of the main menu:

| | |
|-------------------------------|------------------------|
| Reference (REF) | Reference from Keypad |
| Monitor (MON) | Monitoring values |
| Parameters (PAR) | Application parameters |
| System/Fault (SYS/FLT) | System Menu |
| | Active fault |
| | History fault |

Table 35. Keypad menus.

8.4 USING THE KEYPAD

This chapter provides you with information on navigating the menus on Vacon 20 X and editing the values of the parameters.

8.4.1 MAIN MENU

The menu structure of Vacon 20 X control software consists of a main menu and several submenus. Navigation in the main menu is shown below:

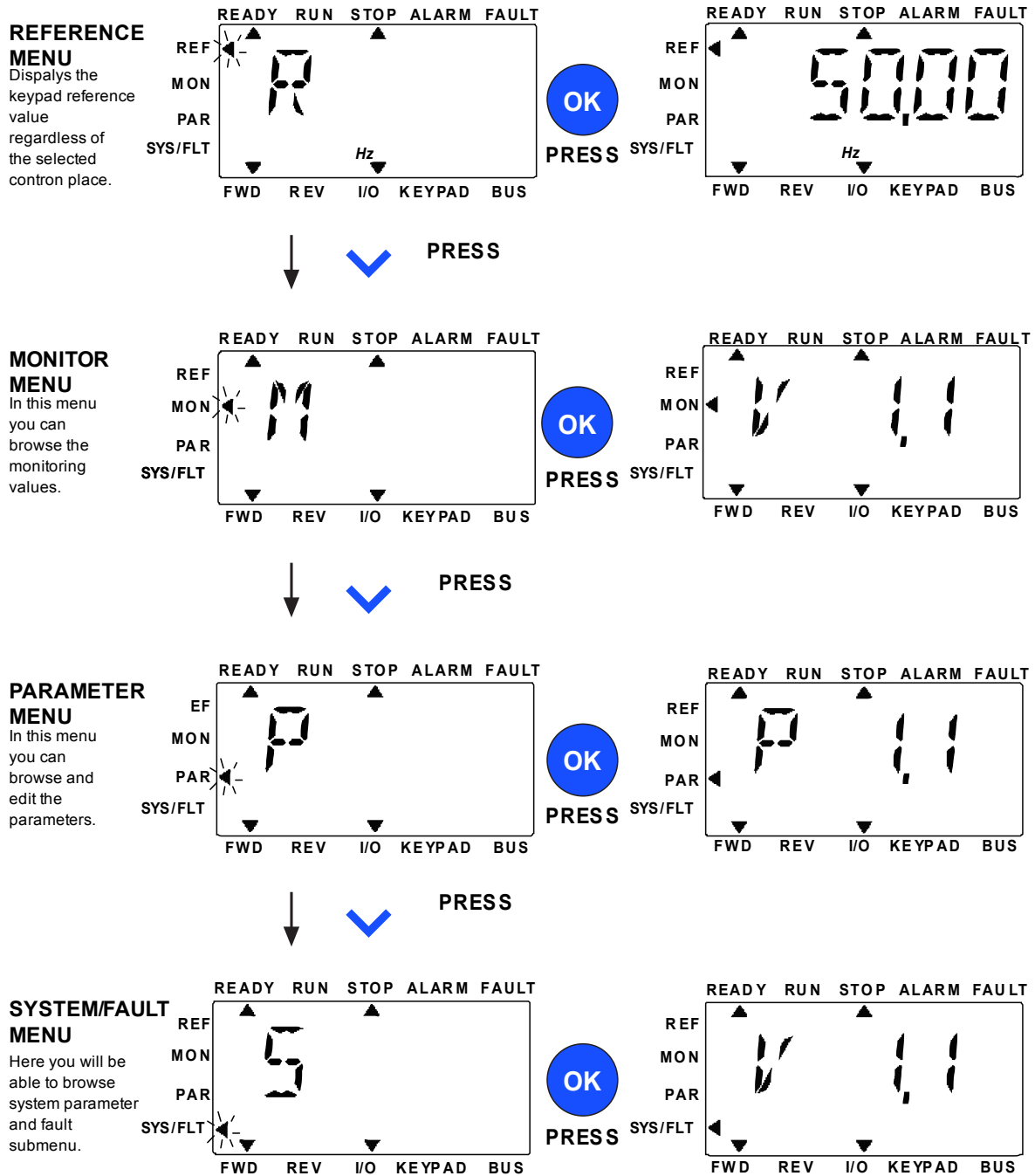

Figure 53. The Main menu of Vacon 20 X.

8.4.2 RESETTING FAULT

When a fault appears and the drive stops examine the cause of the fault, perform the action advised in the Fault Tracing paragraph and reset the fault by pressing the RESET button.

8.4.3 LOCAL/REMOTE CONTROL BUTTON

The LOC/REM button is used for two functions: to quickly access the Control page and to easily change between the Local (Keypad) and Remote control places.

Control places

The *control place* is the source of control where the drive can be started and stopped. Every control place has its own parameter for selecting the frequency reference source. In the VACON® 20 X drive, the *Local control place* is always the keypad. The *Remote control place* is determined by parameter (I/O or Fieldbus). The selected control place can be seen on the status bar of the keypad.

Remote control place

I/O and Fieldbus can be used as remote control places.

Local control

Keypad is always used as control place while in local control. Local control has higher priority than remote control. Switching between Local and Remote Control can be done by pressing the LOC/REM-button on the keypad.

8.4.4 REFERENCE MENU

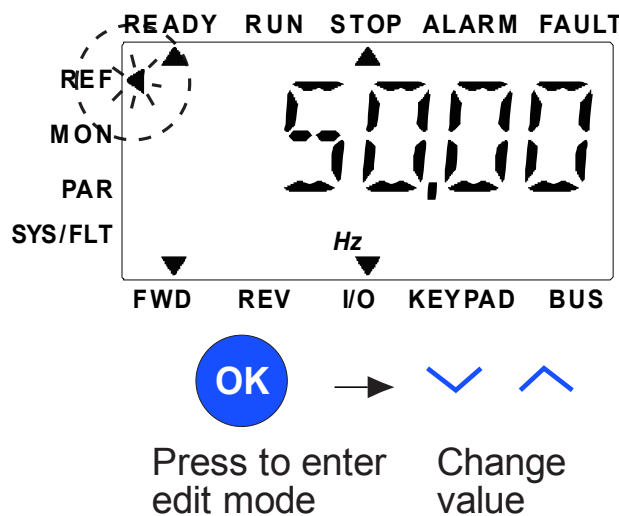

Figure 54. Reference menu.

The reference value can be changed with UP / DOWN button as shown in Figure 54.

If the value has big change, first press Left and Right buttons to select the digit which has to be changed, then press Up button to increase and Down button to decreases the value in the selected digit. The changing reference frequency will be taken into use immediately without pressing OK.

Note! LEFT and RIGHT buttons can be used to change the direction in Ref menu in local control mode.

8.4.5 MONITORING MENU

Monitoring values are actual values of measured signals as well as status of some control settings. It is visible in Vacon 20 X display, but it can not be edited. The monitoring values are listed in the Application Manual.

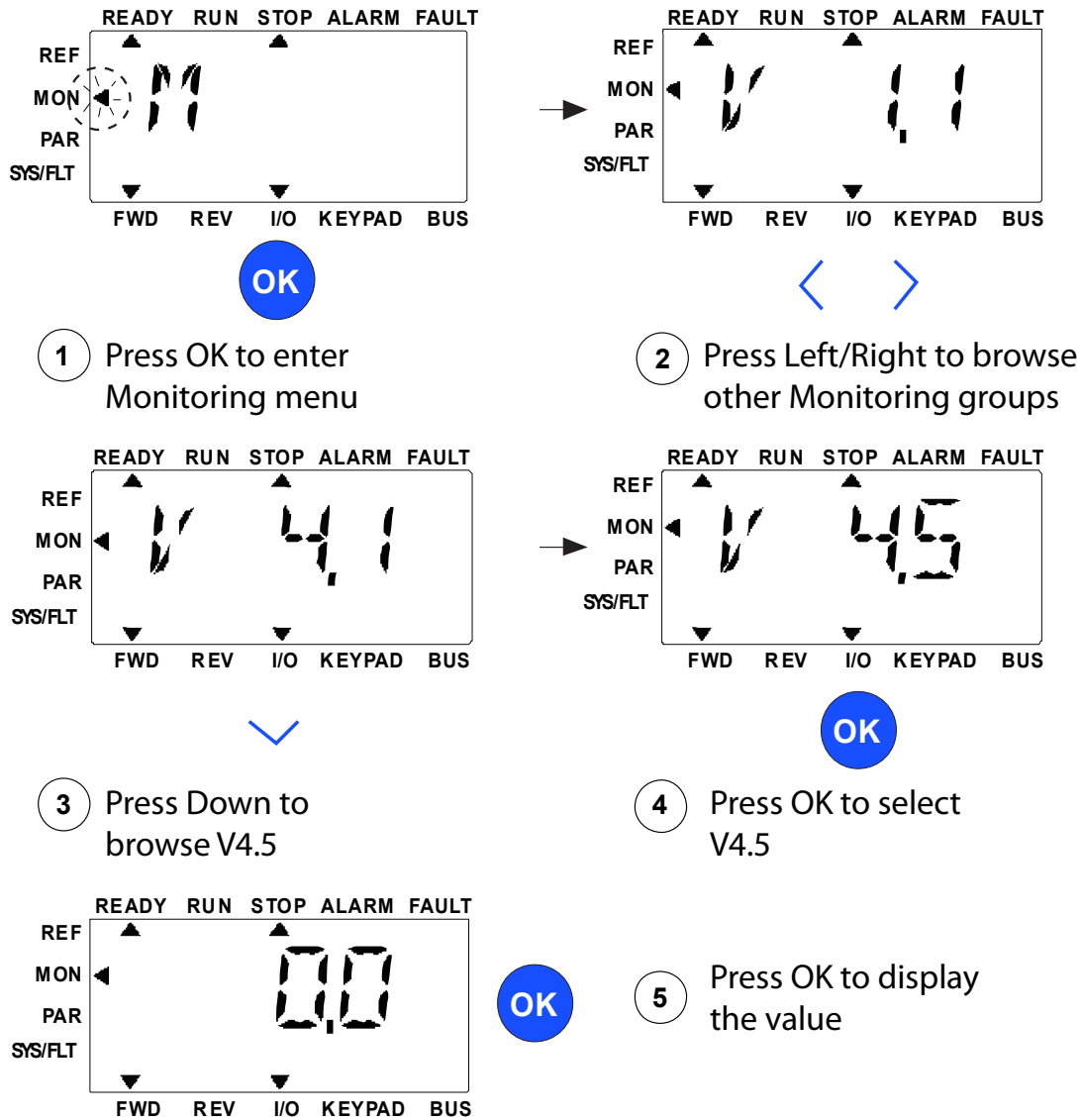

1 Press OK to enter Monitoring menu

2 Press Left/Right to browse other Monitoring groups

3 Press Down to browse V4.5

4 Press OK to select V4.5

5 Press OK to display the value

Figure 55. Monitoring menu.

Pressing Left/Right button to change the actual parameter to the first parameter of the next group, to browse monitor menu from V1.x to V2.1 to V3.1 to V4.1. After entering the desired group, the monitoring values can be browsed by pressing UP/DOWN button, as shown in Figure 55. In MON menu the selected signal and its value are alternating in the display by pressing OK button.

Note! Turn on drive power, arrowhead of main menu is at MON, V x.x or monitor parameter value of Vx.x is displayed in Panel. Display Vx.x or monitor parameter value of Vx.x is determined by the last show status before power shut down.

8.4.6 PARAMETER MENU

In Parameter menu only the Quick setup parameter list is shown as default. To view the other advanced parameter groups, see the Application Manual. The following figure shows the parameter menu view:

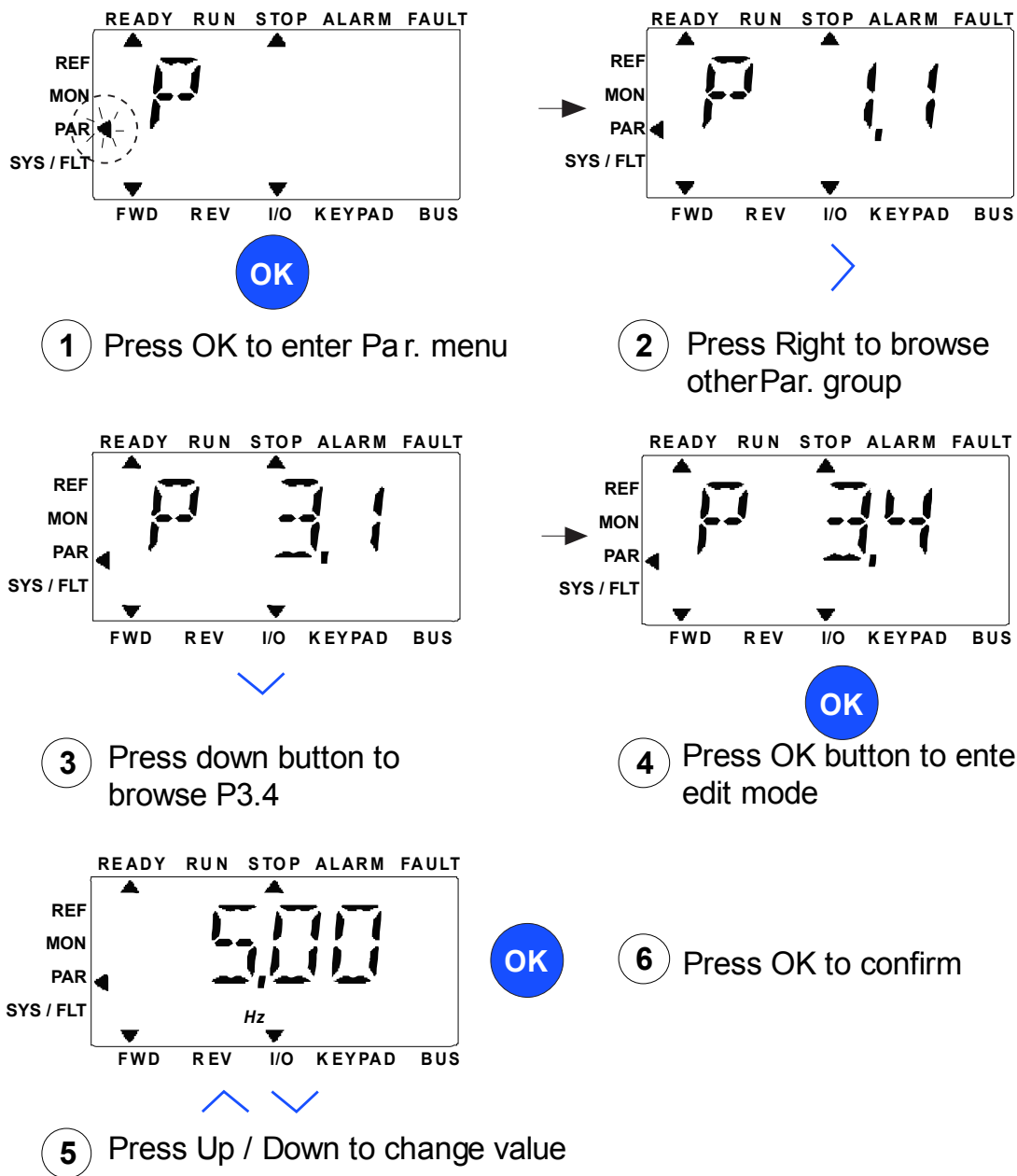

Figure 56.Parameter menu

Change value of a parameter following the procedure below:

1. Locate the parameter.
2. Enter the Edit mode by pressing OK.
3. Set new value with the arrow buttons up/down. You can also move from digit to digit with the arrow buttons left/right if the value is numerical and change then the value with the arrow buttons up/down.
4. Confirm change with OK button or ignore change by returning to previous level with Back/Reset button.

8.4.7 SYSTEM/FAULT MENU

SYS/FLT menu including fault submenu, field bus submenu and system parameter submenu. In system parameter submenu, there are some editable parameter (P) and some not editable parameters (V). The Fault submenu of SYS/FLT menu includes active fault submenu and fault history submenu.

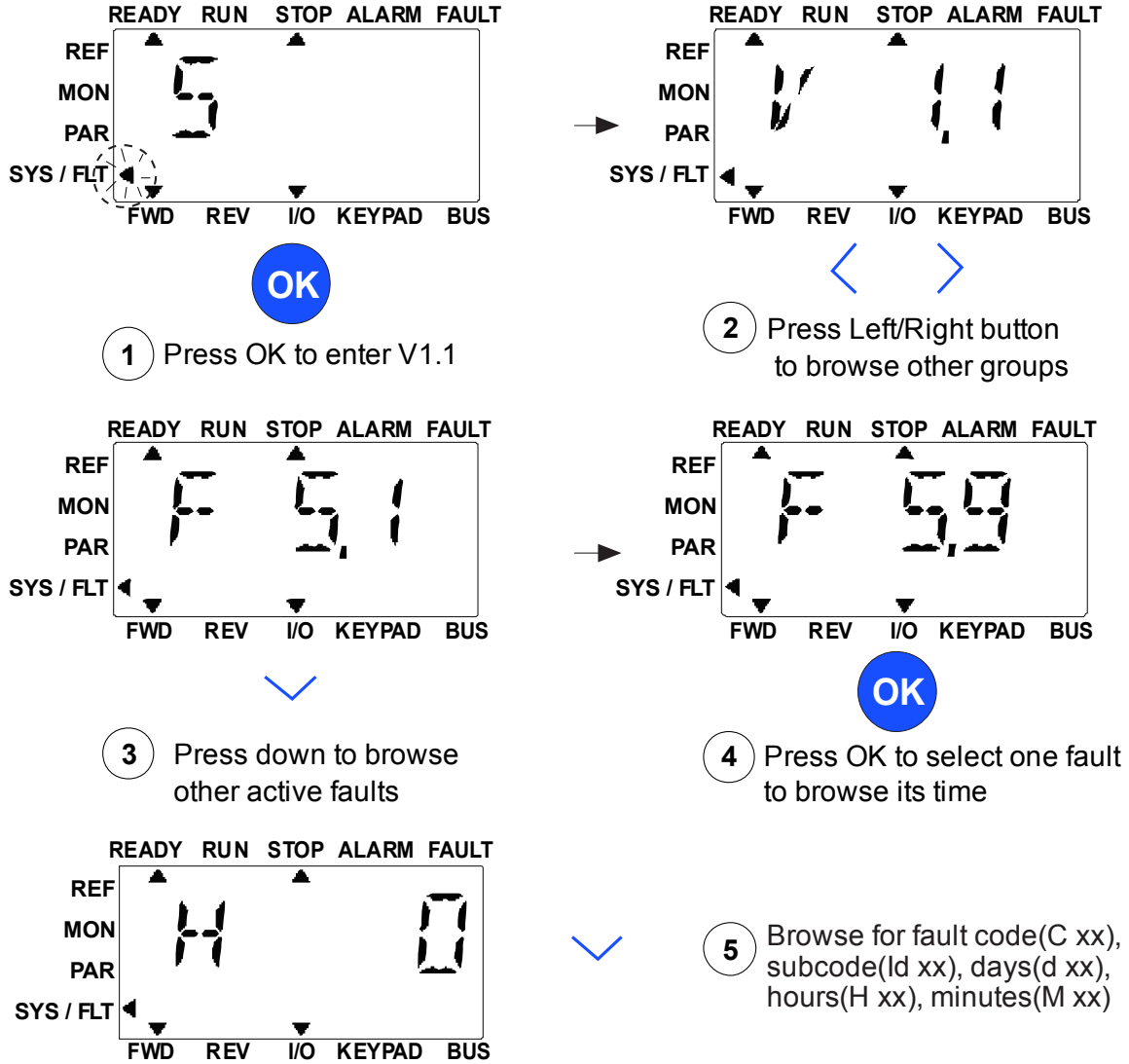

Figure 57. System and Fault menu.

8.4.7.1 *Faults*

Under this menu, you can find *Active faults*, *Reset faults*, *Fault history*, *Counters* and *Software info*.

In active fault situation, FAULT arrow is blinking and the display is blinking active fault menu item with fault code. If there are several active faults, you can check it by entering the active fault submenu F5.x. F5.1 is always the latest active fault code. The active faults can be reset by pressing BACK / RESET button with long time (>2 s), when the API is in active fault submenu level (F5.x). If the fault cannot be reset, the blinking continues. It is possible to select other display menus during active fault, but in this case the display returns automatically to the fault menu if no button is pressed in 10 seconds. The fault code, subcode and the operating day, hour and minute values at the fault instant are shown in the value menu (operating hours = displayed reading).

Active faults

| Menu | Function | Note |
|----------------------|--|---|
| Active faults | When a fault/faults appear(s), the display with the name of the fault starts to blink. Press OK to return to the Diagnostics menu. The <i>Active faults</i> submenu shows the number of faults. Select the fault and push OK to see the fault-time data. | The fault remains active until it is cleared with the RESET button or with a reset signal from the I/O terminal or fieldbus or by choosing <i>Reset faults</i> (see below). The memory of active faults can store the maximum of 10 faults in the order of appearance. |

Fault history

| Menu | Function | Note |
|----------------------|---|---|
| Fault history | 10 latest faults are stored in the Fault history. | Entering the Fault history and clicking OK on the selected fault shows the fault time data (details). |

8.4.8 FAULT TRACING

| Fault code | Fault name | Subcode | Possible cause | Remedy |
|------------|--------------|---------|--|---|
| 1 | Overcurrent | | AC drive has detected too high a current ($>4 \cdot I_M$) in the motor cable: <ul style="list-style-type: none"> sudden heavy load increase short circuit in motor cables unsuitable motor | Check loading. Check motor. Check cables and connections. Make identification run. Check ramp times. |
| 2 | Overvoltage | | The DC-link voltage has exceeded the limits defined. <ul style="list-style-type: none"> too short a deceleration time brake chopper is disabled high overvoltage spikes in supply Start/Stop sequence too fast | Make deceleration time longer. Use brake chopper or brake resistor (available as options). Activate overvoltage controller. Check input voltage. |
| 3 | Earth fault | | Current measurement has detected that the sum of motor phase current is not zero. <ul style="list-style-type: none"> insulation failure in cables or motor | Check motor cables and motor. |
| 8 | System Fault | 84 | MPI communication crc error | Reset the fault and restart. Should the fault re-occur, contact the distributor near to you. |
| | | 89 | HMI receives buffer overflow | Check PC-drive cable. Try to reduce ambient noise |
| | | 90 | Modbus receives buffer overflow | Check Modbus specifications for time-out. Check cable length. Reduce ambient noise. Check baudrate. |
| | | 93 | Power identification error | Try to reduce ambient noise. Reset the fault and restart. Should the fault re-occur, contact the distributor near to you. |
| | | 97 | MPI off line error | Reset the fault and restart. Should the fault re-occur, contact the distributor near to you. |
| | | 98 | MPI driver error | Reset the fault and restart. Should the fault re-occur, contact the distributor near to you. |
| | | 99 | Option board driver error | Check contact in option board slot Try to reduce ambient noise; Reset the fault and restart. Should the fault re-occur, contact the distributor near to you. |
| | | 100 | Option board configuration error | Check contact in option board slot Try to reduce ambient noise; Should the fault re-occur, contact the distributor near to you. |

Table 36. Fault codes and descriptions.

| Fault code | Fault name | Subcode | Possible cause | Remedy |
|------------|---------------------|---|-------------------------------------|---|
| 8 | System Fault | 101 | Modbus buffer overflow | Check Modbus specifications for time-out. Check cable length. Reduce ambient noise. Check baudrate. |
| | | 104 | Option board channel full | Check contacts in option board slot. Try to reduce ambient noise. Should the fault re-occur, contact the distributor near to you. |
| | | 105 | Option board memory allocation fail | Check contacts in option board slot. Try to reduce ambient noise. Should the fault re-occur, contact the distributor near to you. |
| | | 106 | Option board Object queue full | Check contacts in option board slot. Try to reduce ambient noise. Should the fault re-occur, contact the distributor near to you. |
| | | 107 | Option board HMI queue full | Check contacts in option board slot. Try to reduce ambient noise. Should the fault re-occur, contact the distributor near to you. |
| | | 108 | Option board SPI queue full | Check contacts in option board slot. Try to reduce ambient noise. Should the fault re-occur, contact the distributor near to you. |
| | | 111 | Parameter copy error | Check if parameter set is compatible with drive. Do not remove Keypad until copy is finished. |
| | | 113 | Frequency detective timer overflow | Check keypad contacts. Try to reduce ambient noise. Should the fault re-occur, contact the distributor near to you. |
| | | 114 | PC control time out fault | Do not close Vacon Live when PC control is active. Check PC-Drive cable. Try to reduce ambient noise. |
| | | 115 | DeviceProperty data format | Reset the fault and restart. Should the fault re-occur, contact the distributor near to you. |
| 120 | Task stack overflow | Reset the fault and restart. Should the fault re-occur, contact the distributor near to you. | | |

Table 36. Fault codes and descriptions.

| Fault code | Fault name | Subcode | Possible cause | Remedy |
|------------|---------------------------|---------|---|--|
| 9 | Undervoltage | | DC-link voltage is under the voltage limits defined. <ul style="list-style-type: none"> • most probable cause: too low a supply voltage • AC drive internal fault • defect input fuse • external charge switch not closed NOTE! This fault is activated only if the drive is in Run state. | In case of temporary supply voltage break reset the fault and restart the AC drive. Check the supply voltage. If it is adequate, an internal failure has occurred. Contact the distributor near to you. |
| 10 | Input phase | | Input line phase is missing. | Check supply voltage, fuses and cable. |
| 11 | Output phase | | Current measurement has detected that there is no current in one motor phase. | Check motor cables and motor. |
| 13 | AC drive undertemperature | | Too low temperature measured in power unit's heatsink or board. Heatsink temperature is under - 10°C. | Check the ambient temperature. |
| 14 | AC drive overtemperature | | Too high temperature measured in power unit's heatsink or board. Heatsink temperature is over 100°C. | Check the correct amount and flow of cooling air. Check the heatsink for dust. Check the ambient temperature. Make sure that the switching frequency is not too high in relation to ambient temperature and motor load. |
| 15 | Motor stalled | | Motor is stalled. | Check motor and load. Insufficient motor power, check motor stall protection parametrization. |
| 16 | Motor overtemperature | | Motor is overloaded. | Decrease motor load. If no motor overload exists, check the temperature model parameters. |
| 17 | Motor underload | | Motor is under loaded | Check load. Check underload protection parametrization. |
| 19 | Power overload | | Supervision for drive power | Drive power is to high: decrease load. |
| 25 | Watchdog | | Error in the microprocessor monitoring Malfunction Component fault | Reset the fault and restart. If the fault occurs again, please contact your closest Vacon representative. |
| 27 | Back EMF | | Protection of unit when starting with rotating motor | Reset the fault and restart. Should the fault re-occur, contact the distributor near to you. |
| 30 | STO fault | | Safe torque off signal does not allow drive to be set as ready | Reset the fault and restart. Should the fault re-occur, contact the distributor near to you. |

Table 36. Fault codes and descriptions.

| Fault code | Fault name | Subcode | Possible cause | Remedy |
|------------|------------------------------|---------|---|---|
| 35 | Application error | 0 | Firmware Interface version between Application and Control not matching | Load a compatible application. Please contact your closest Vacon representative. |
| | | 1 | Application software flash error | Reload Application |
| | | 2 | Application header error | Load a compatible application. Please contact your closest Vacon representative. |
| 41 | IGBT temp | | IGBT temperature (UnitTemperature + I2T) too high | Check loading. Check motor size. Make identification run. |
| 50 | 4 mA fault (Analog input) | | Selected signal range: 4...20 mA (see Application Manual) Current less than 4 mA Signal line broken detached The signal source is faulty | Check the analog input's current source and circuit. |
| 51 | External fault | | Error message on digital input. The digital input was programmed as an input for external error messages. The input is active. | Check the programming and check the device indicated by the error message. Check the cabling for the respective device as well. |
| 52 | Keypad Communication fault | | The connection between the control keypad and the frequency converter is broken. | Check keypad connection and keypad cable. |
| 53 | Fieldbus communication fault | | The data connection between the fieldbus master and fieldbus board is broken | Check installation and fieldbus master. |
| 54 | Fieldbus Interface error | | Defective option board or slot | Check board and slot. |
| 55 | Wrong run command | | Wrong run alarm and stop command | Run forward and backward are activated at the same time |
| 56 | Temperature | | Temperature fault | Board OPTBH is installed and measured temperature is above (or below) the limit |
| 57 | Identification | | Identification alarm | Motor identification has not been successfully completed |
| 63 | Quick Stop | | Quick Stop activated | The drive has been stopped with Quick Stop digital input or Quick Stop command by fieldbus |

Table 36. Fault codes and descriptions.

8.5 OPTION BOARDS

VACON[®] 20 X drive family embodies a wide selection of expander boards with which the available I/O of VACON[®] 20 X frequency converter can be increased and its versatility improved.

There is one board slot (labelled D) on the VACON[®] 20 X control board. To locate the slot, see Chapter 5. Usually, when the AC drive is delivered from the factory, the control unit doesn't include any option board in the board slot.

The following option boards are supported:

| Order Code | Description | Note |
|-------------|---|--|
| OPT-B1-V | Option board with six bidirectional terminals. | With jumper blocks it's possible to use each terminal as digital input or as digital output. |
| OPT-B2-V | I/O expander board with a thermistor input and two relay outputs. | |
| OPT-B4-V | I/O expander board with one galvanically isolated analogue input and two galvanically isolated analogue outputs (standard signals 0(4)...20mA). | |
| OPT-B5-V | I/O expander board with three relay outputs | |
| OPT-B9-V | I/O expander board with five 42...240 VAC digital inputs and one relay output. | |
| OPT-BF-V | I/O expander board with analogue output, digital output and relay output. | On the OPTBF board, there is one jumper block for selecting the analogue output mode (mA/V). |
| OPT-BH-V | Temperature measurement board with three individual channels. | Supported sensors: PT100, PT1000, NI1000, KTY84-130, KTY84-150, KTY84-131 |
| OPT-BK-V | ASi option board | AS-interface option card |
| OPT-C4-V | Lonworks option board | Pluggable connector with screw terminals |
| OPT-C3/E3-V | Profibus DP option board | Pluggable connector with screw terminals |
| OPT-C5/E5-V | Profibus DP option board | 9-pin Sub-D terminal |
| OPT-C6/E6-V | CANopen option board | |
| OPT-C7/E7-V | DeviceNet option board | |
| OPT-CI-V | Modbus TCP option board | |
| OPT-CP-V | Profinet option board | |
| OPT-CQ-V | Ethernet IP option board | |
| OPT-EC-V | EtherCat option board | |

Table 37. Option boards supported in VACON[®] 20 X

See the Option boards User's Manual to use and install the option boards.

8.5.1 OPTION BOARD INSTALLATION



NOTE! Do not add or replace option boards or fieldbus boards on an AC drive with the power switched on. This may damage the boards.

1

- Remove the HMI cap and open the cover of the drive.

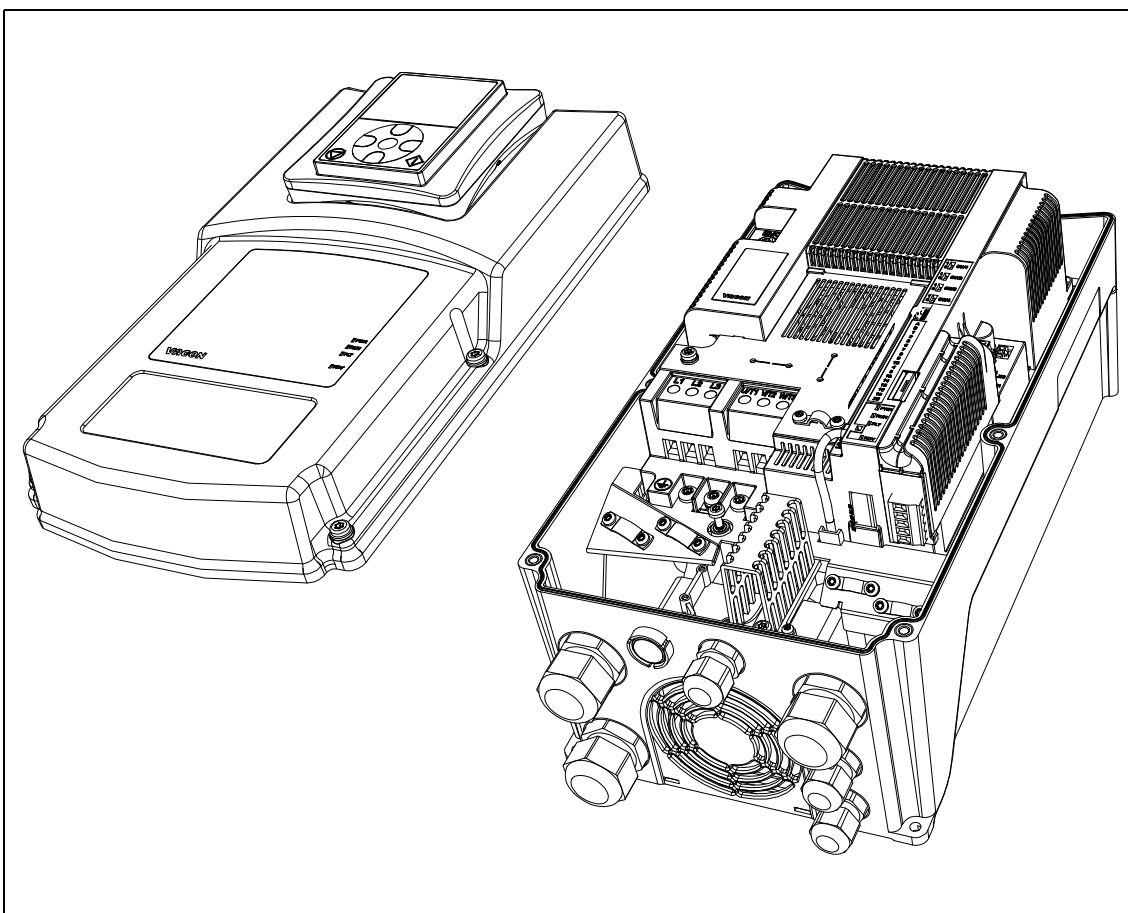

Figure 58. Opening the main cover, MU3 example.



The relay outputs and other I/O-terminals may have a dangerous control voltage present even when the drive is disconnected from mains.

2

- Remove the option slot cover.

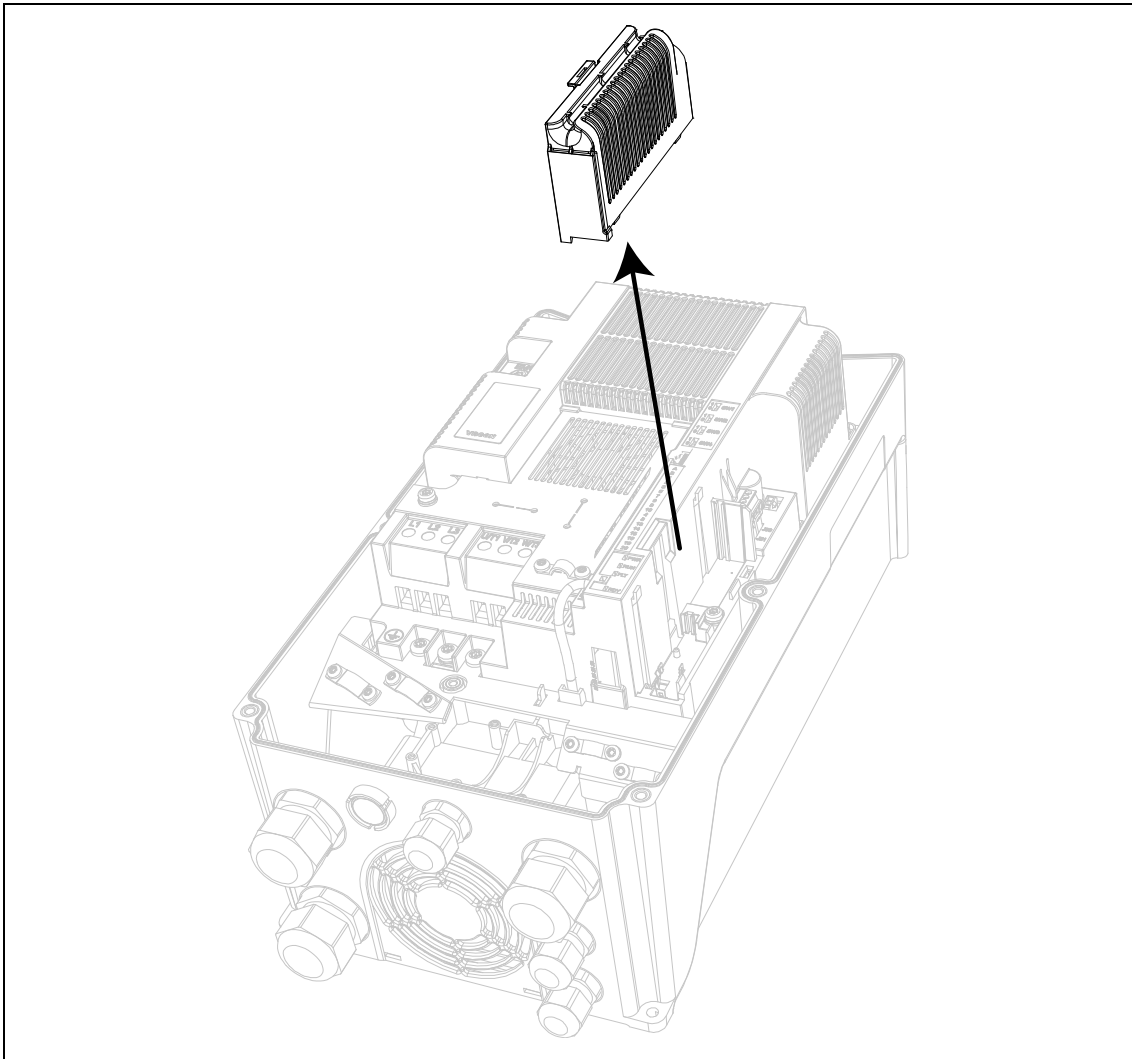
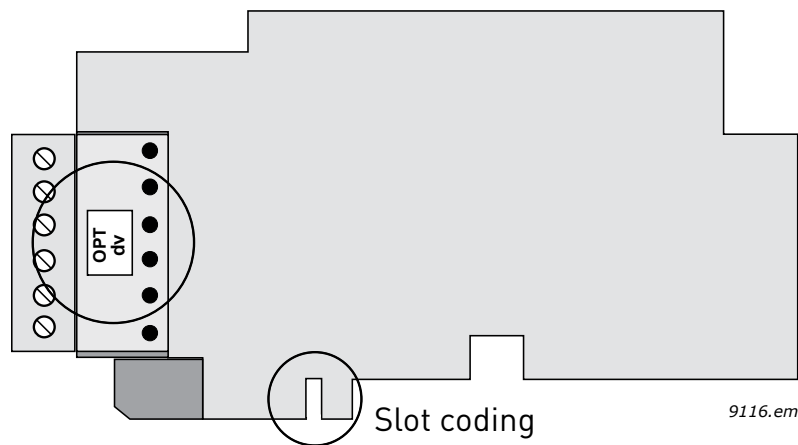

Figure 59. Removing the option slot cover.

- Make sure that the sticker on the connector of the board says “dv” (dual voltage). This indicates that the board is compatible with Vacon 20 X. See below:



- **NOTE:** Incompatible boards cannot be installed on Vacon 20 X. Compatible boards have a slot coding that enables the placing of the board (see above)

- | | |
|----------|---|
| 4 | <ul style="list-style-type: none"> • Install the option board into the slot as shown in the picture below. |
|----------|---|

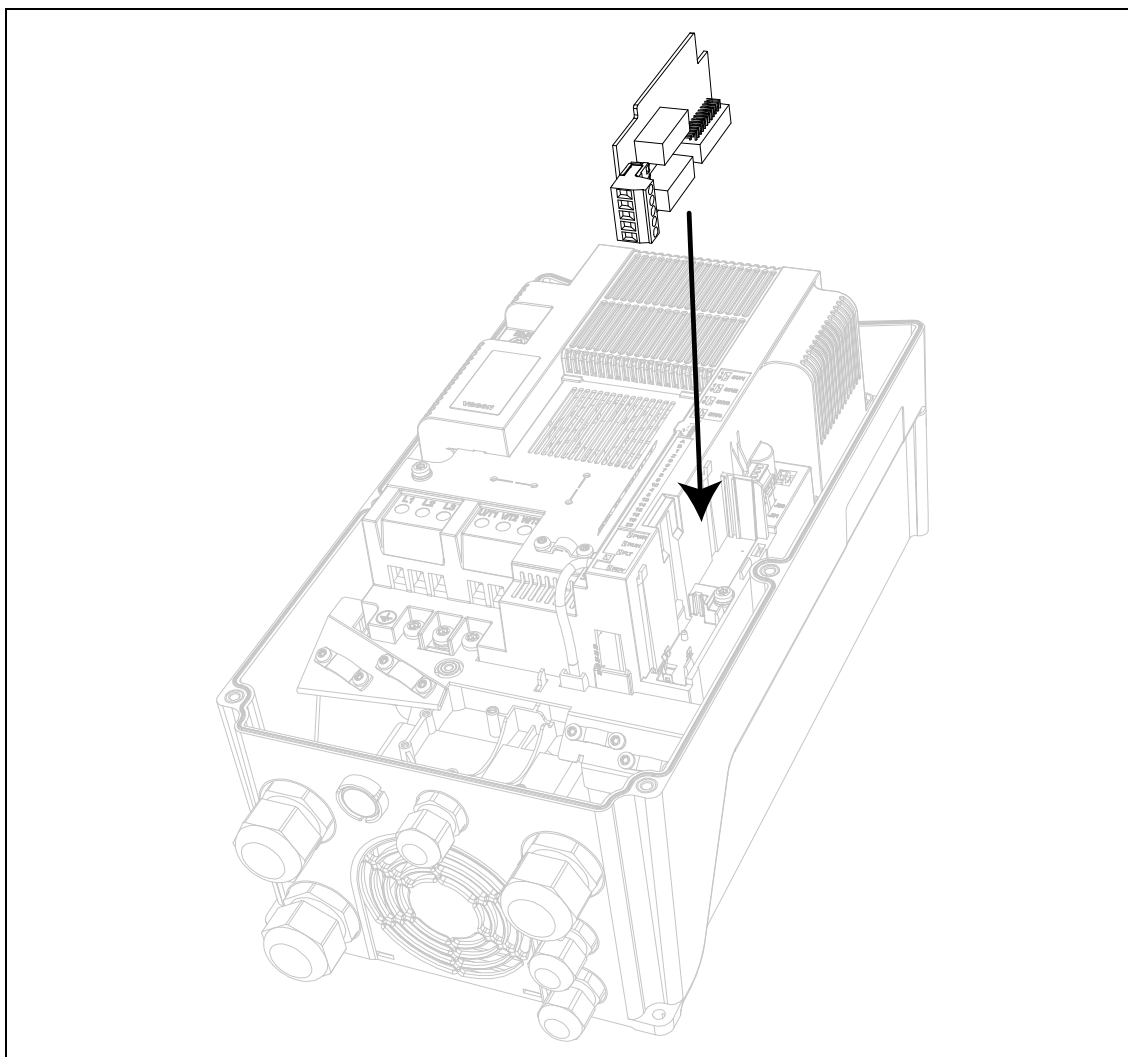

Figure 60. Option board installation.

- | | |
|----------|--|
| 5 | <ul style="list-style-type: none"> • Mount the option slot cover. |
|----------|--|

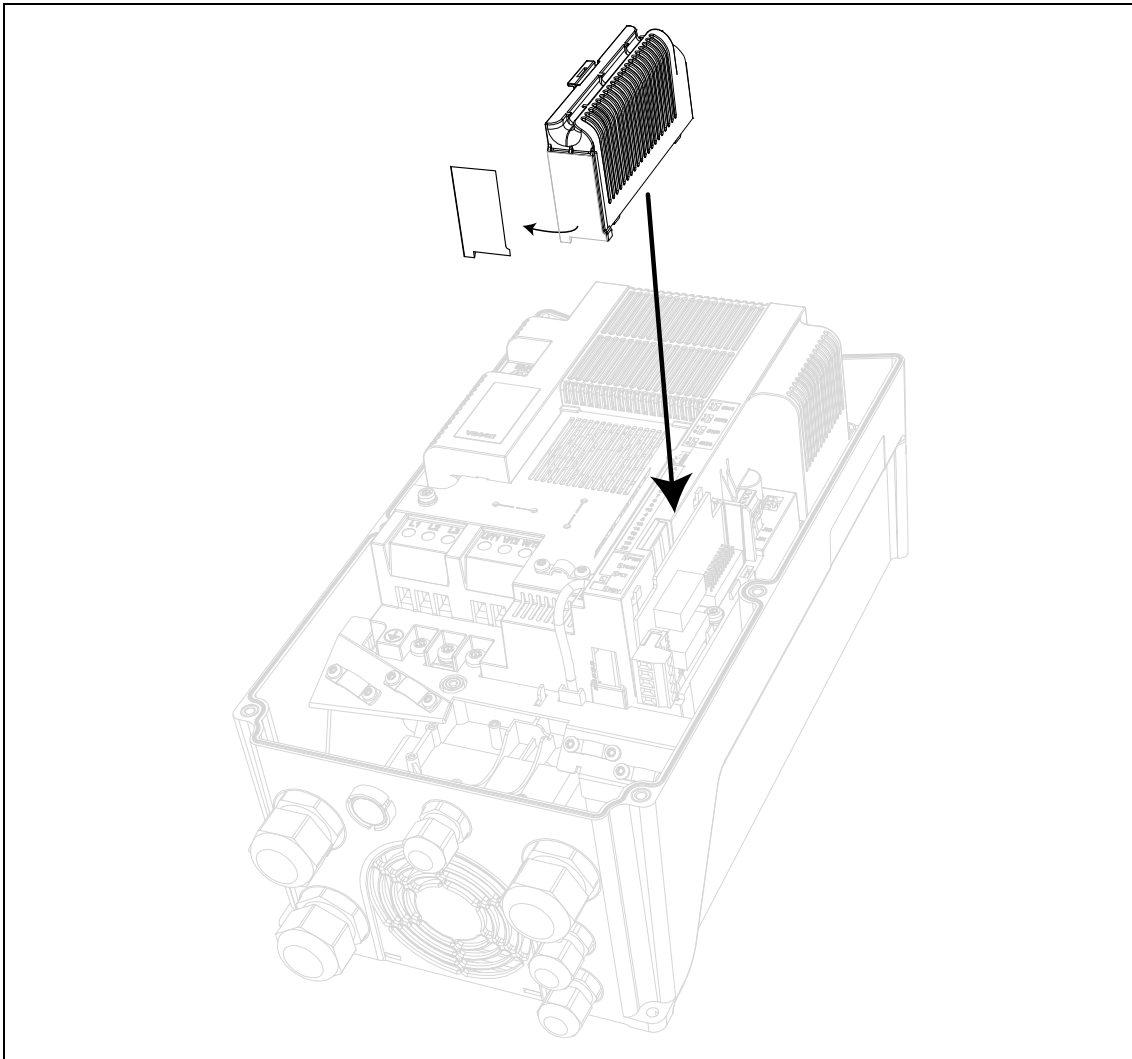

Figure 61. Mounting of option slot cover: remove the plastic opening for the option board terminals.

8.6 MAINS SWITCH

The purpose of the *Mains switch* is to disconnect the VACON® 20 X from the mains when, for example, service actions are needed. The mains switch is available as option and it can be integrated in the drive. The switch can be mounted on the front side of the drive. See Figure 62.

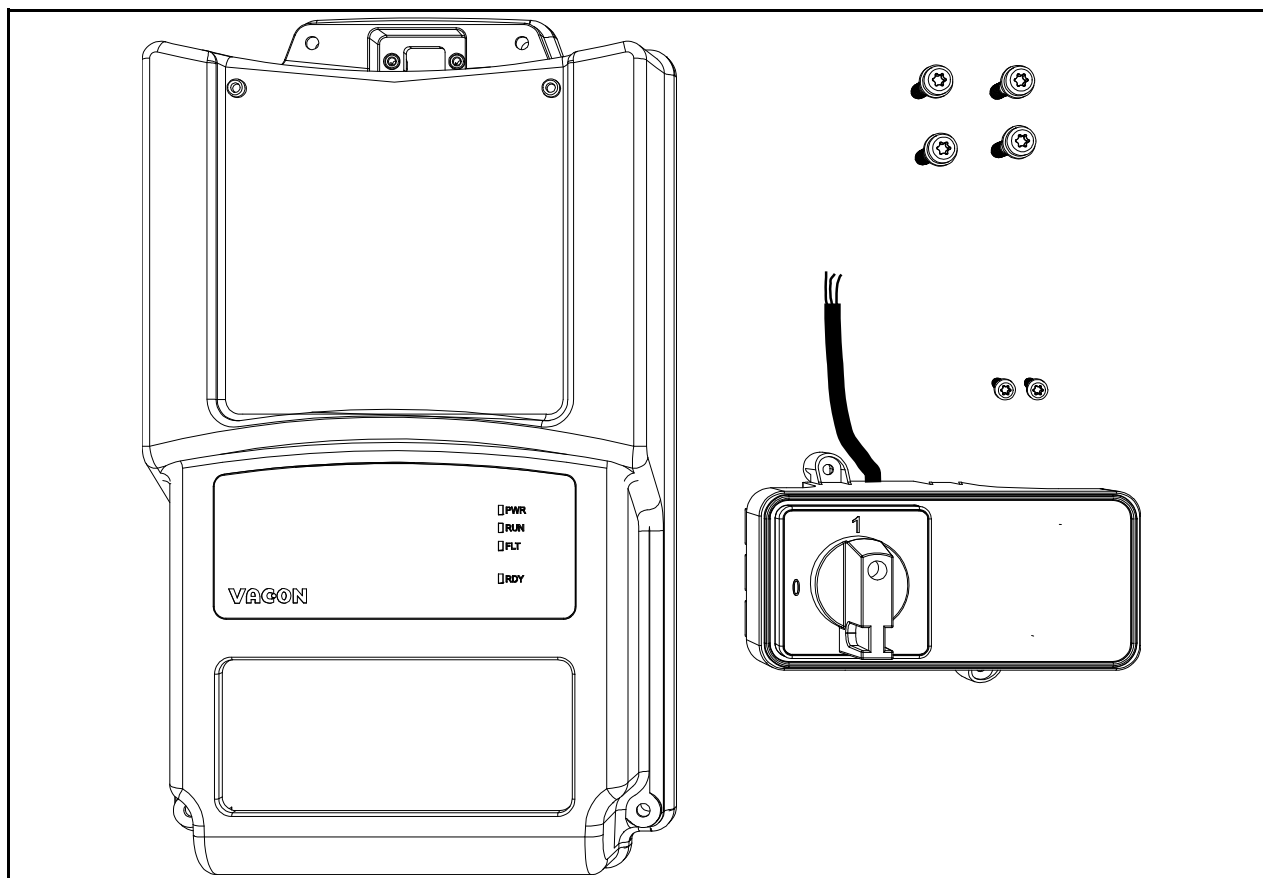

Figure 62. The mains switch option spare kit (MU2 example).

| Frame size | Description and type code | Item | Quantity |
|--------------------------|---------------------------------------|--------------------------------|----------|
| MU2 (3-phase version) | MU2 QDSS option spare kit 60S01128 | Main switch 40A NLT40 assembly | 1 |
| | | MU2 cover for main switch | 1 |
| | | M4x14 screw | 2 |
| | | M5x23 screws | 4 |
| MU2 (1-phase version) | MU2 QDSS option spare kit 60S01234 | Main switch 40A NLT40 assembly | 1 |
| | | MU2 cover for main switch | 1 |
| | | M4x14 screw | 2 |
| | | M5x23 screws | 4 |
| MU3 | MU3 QDSS option spare kit 60S01129 | Main switch 40A NLT40 assembly | 1 |
| | | MU3 cover for main switch | 1 |
| | | M4x14 screw | 2 |
| | | M5x23 screws | 6 |

Table 38. Mains switch kit content.

8.6.1 INSTALLATION

| | |
|----------|---|
| 1 | <ul style="list-style-type: none"> Remove the HMI cap and the cover from the drive. See the Figure 63. |
|----------|---|

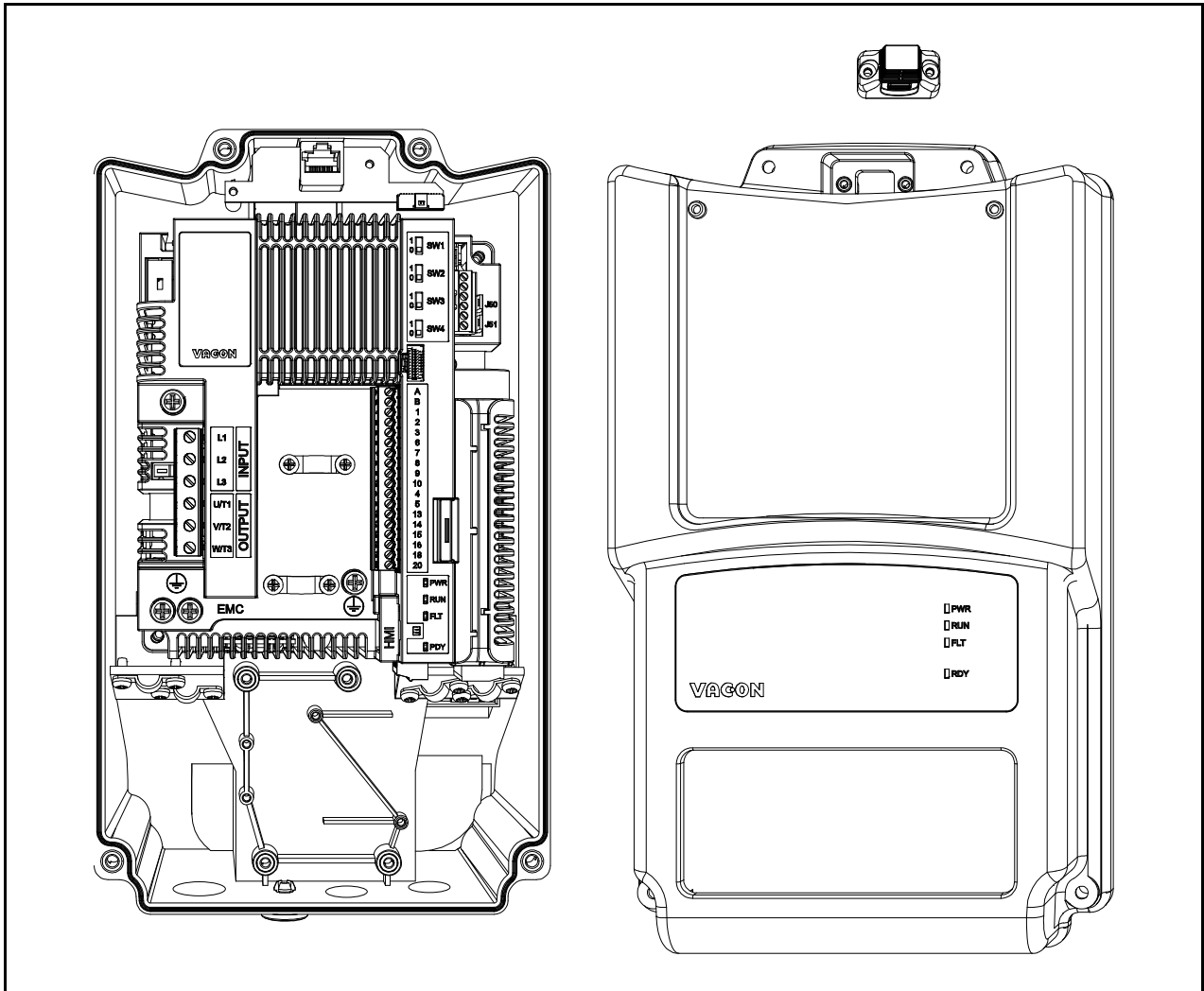

Figure 63. Cover open (MU2 3-phase example).

| | |
|----------|--|
| 2 | <ul style="list-style-type: none"> Open only the inlet holes where you need to run the cables. Cables pass through this inlet hole. |
| 3 | <ul style="list-style-type: none"> Connect the supply cable to the Mains switch passing through the cable gland from the bottom side (use the cable gland for sealing the cable to the drive) and then through the terminal box as shown in the figure below. |
| 4 | <ul style="list-style-type: none"> Place the Mains switch with the cables inside the drive and fix it with its screws. |
| 5 | <ul style="list-style-type: none"> Connect the cables from the Mains switch to the line terminal. The cables have to be connected to the terminals L1, L2 and L3. <p>Note:</p> <ul style="list-style-type: none"> For single-phase version connect BLU cable to N and BROWN cable to L. |
| 6 | <ul style="list-style-type: none"> Fix the cables with cable clamp. |

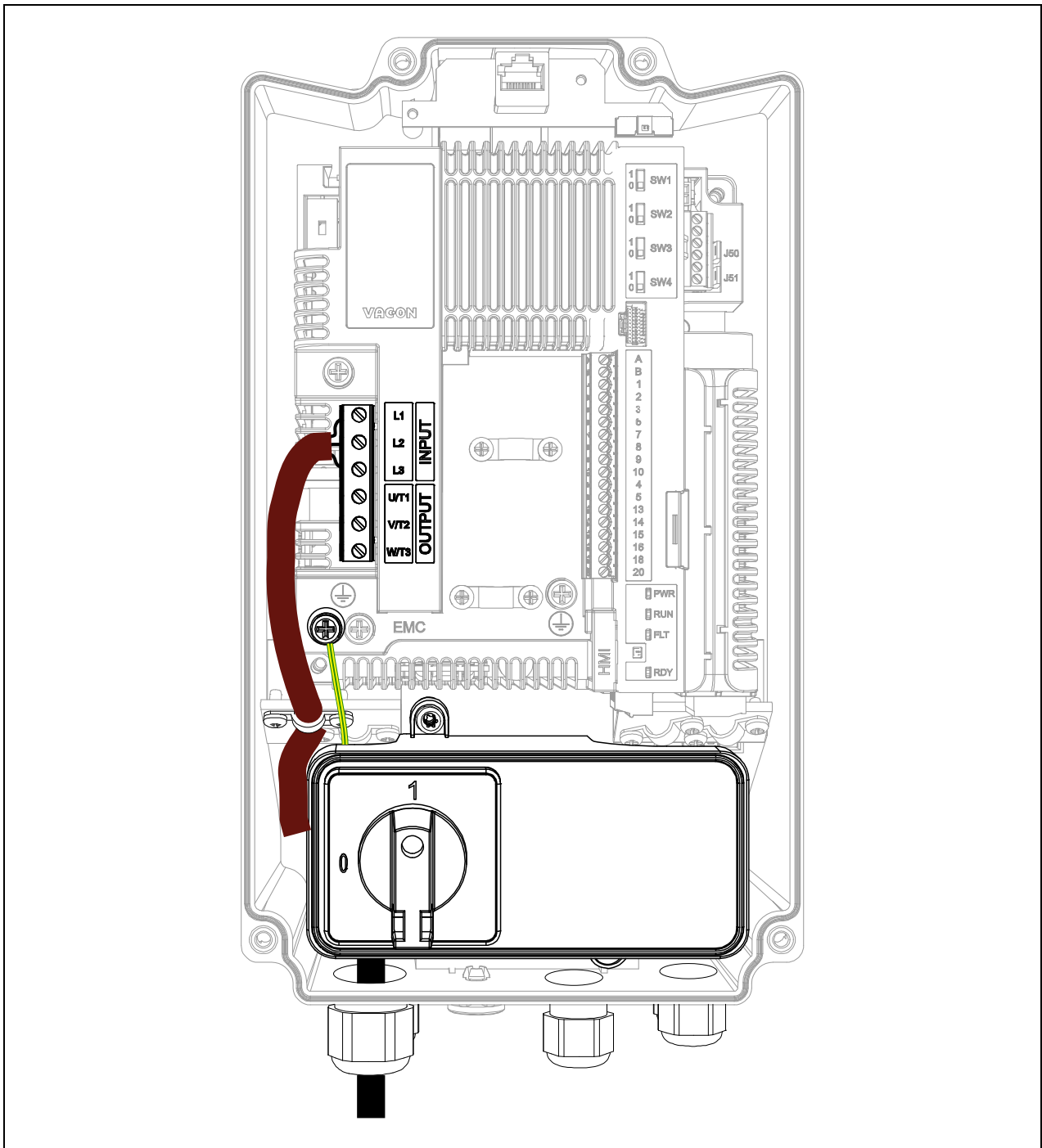

Figure 64. Mains switch and cables connected (MU2 3-phase example).

- | | |
|----------|---|
| 7 | <ul style="list-style-type: none"> • Connect the GROUND wire to the proper terminal (see the yellow-green cable on Figure 64). |
|----------|---|

8

- Mount the plastic cover onto the drive with its screws and HMI cap: the installation process has been completed. See Figure 65.

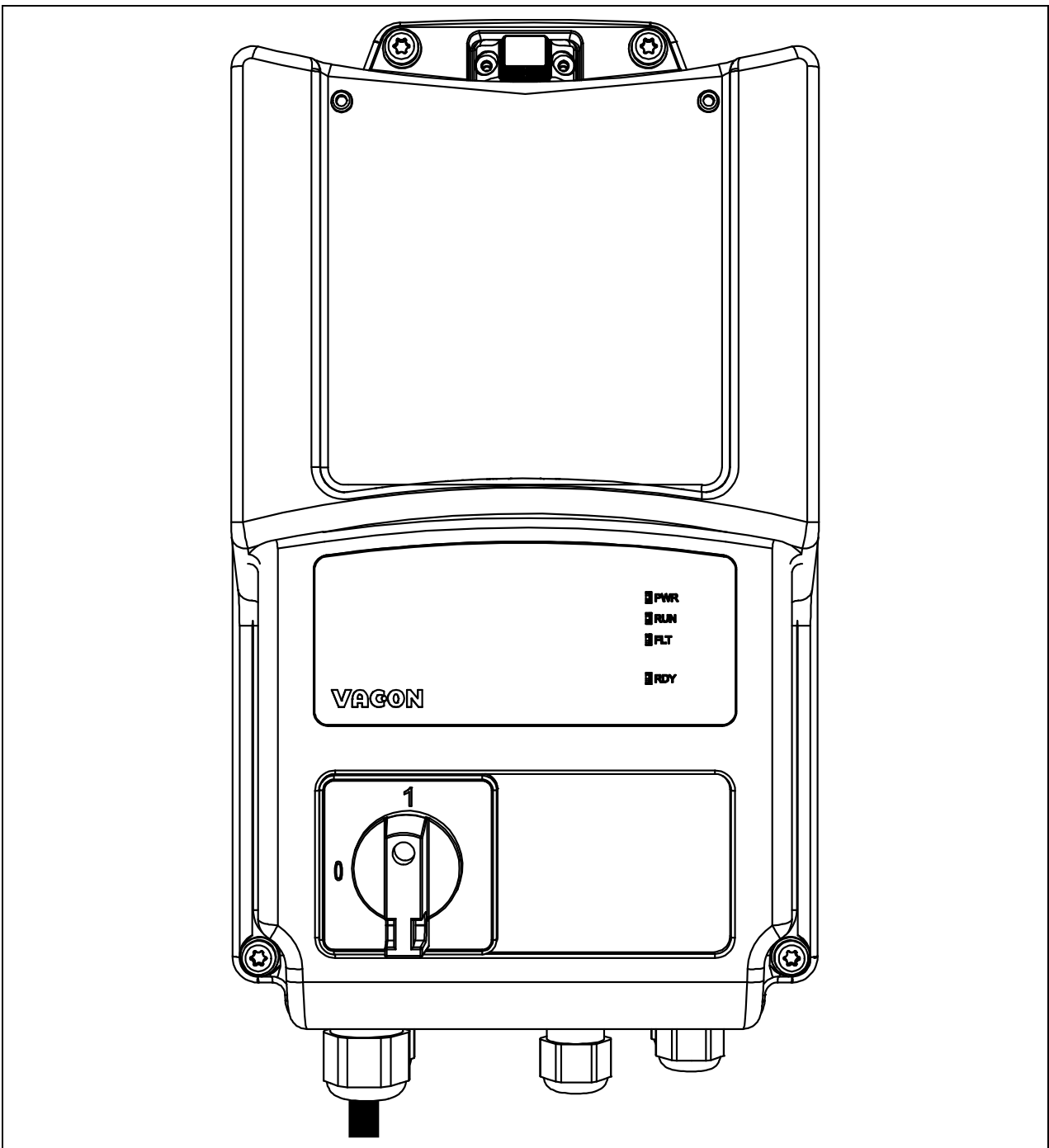

Figure 65. Mount the plastic cover.

8.7 SIMPLE OPERATOR PANEL

The purpose of the *Simple operator panel* is to provide a local control with Start/Stop selector and potentiometer for frequency reference together with a mains switch to disconnect the VACON® 20 X from the mains when, for example, service actions are needed. This option can be mounted on the front side of the drive. See Figure 66.

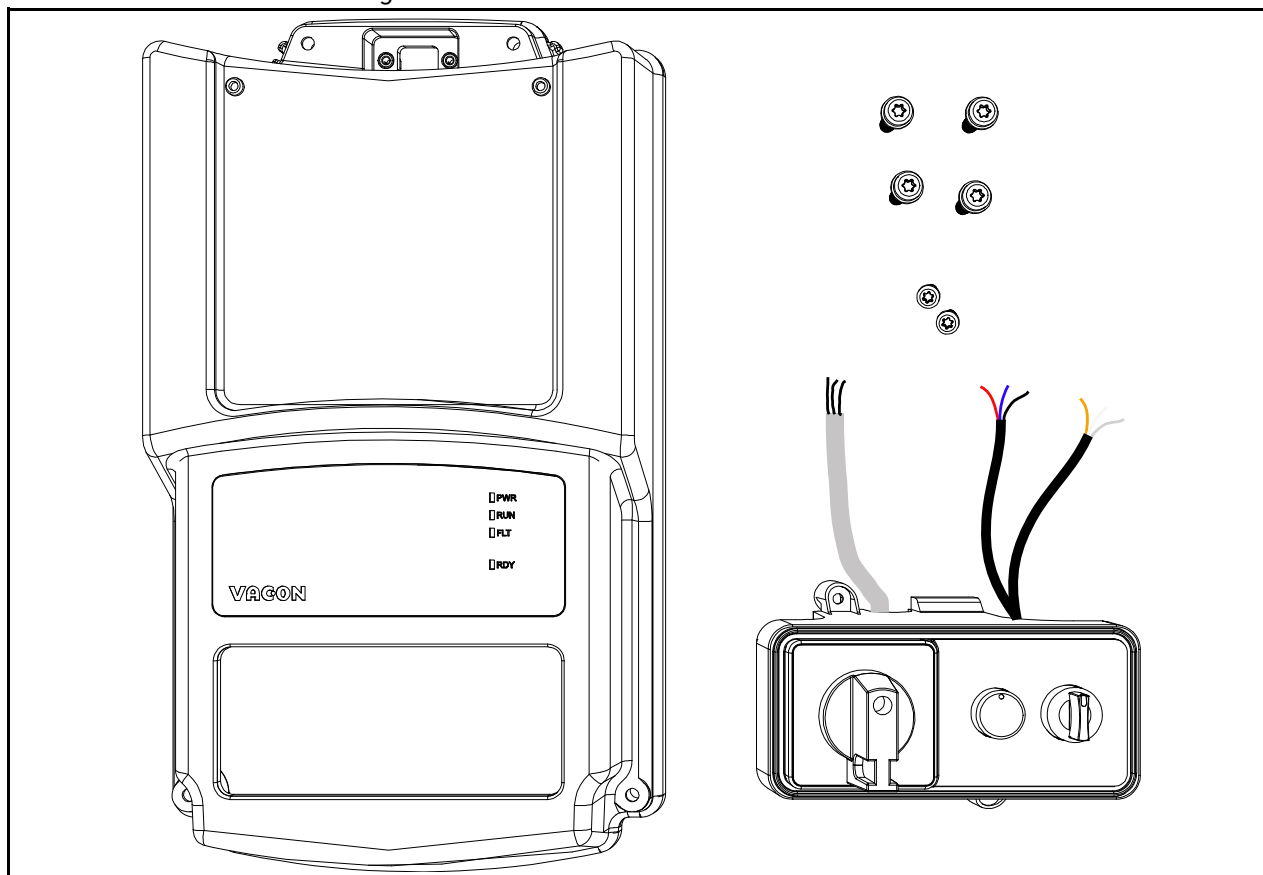

Figure 66. The Simple operator panel option spare kit (MU2 example).

| Frame size | Description and type code | Item | Quantity |
|--------------------------|---------------------------------------|---|----------|
| MU2 (3-phase version) | MU2 QDSH option spare kit 60S01208 | Main switch 40A NLT40 and operator panel assembly | 1 |
| | | MU2 cover for main switch | 1 |
| | | M4x14 screw | 2 |
| | | M5x23 screws | 4 |
| MU2 (1-phase version) | MU2 QDSH option spare kit 60S01235 | Main switch 40A NLT40 and operator panel assembly | 1 |
| | | MU2 cover for main switch | 1 |
| | | M4x14 screw | 2 |
| | | M5x23 screws | 4 |
| MU3 | MU3 QDSH option spare kit 60S01209 | Main switch 40A NLT40 and operator panel assembly | 1 |
| | | MU3 cover for main switch | 1 |
| | | M4x14 screw | 2 |
| | | M5x23 screws | 6 |

Table 39. Simple operator panel kit content.

8.7.1 INSTALLATION

| | |
|----------|---|
| 1 | <ul style="list-style-type: none"> Remove the HMI cap and the cover from the drive. See the Figure 67. |
|----------|---|

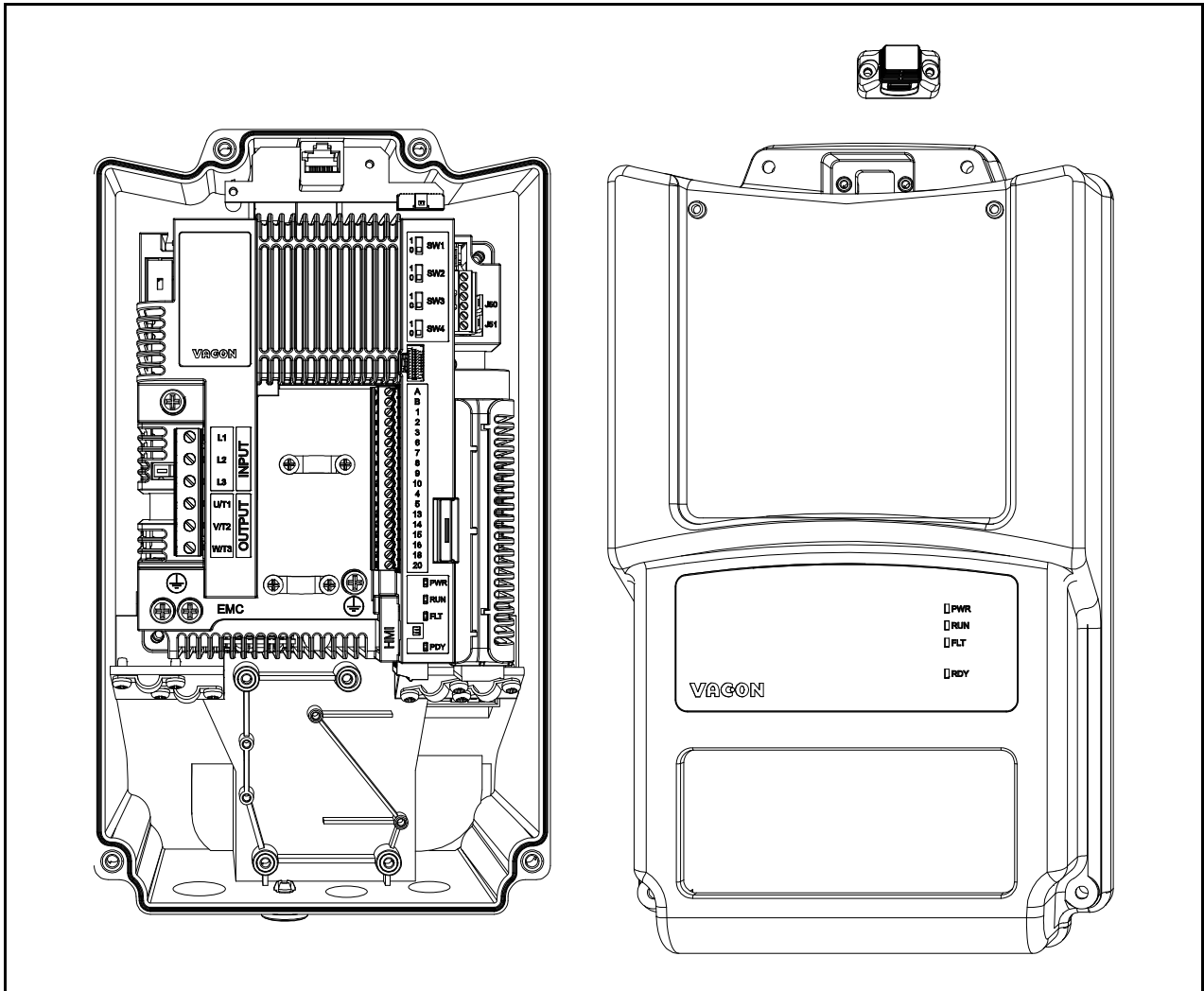

Figure 67. Cover open (MU2 3-phase example).

| | |
|----------|---|
| 2 | <ul style="list-style-type: none"> Open only the inlet holes where you need to run the cables. Cables pass through this inlet hole. |
| 3 | <ul style="list-style-type: none"> Connect the supply cable to the Mains switch passing through the cable gland from the bottom side (use the cable gland for sealing the cable to the drive) and then through the terminal box as shown in the figure below. |
| 4 | <ul style="list-style-type: none"> Place the Simple Operator panel assembly with the cables inside the drive and fix it with its screws. |
| 5 | <ul style="list-style-type: none"> Connect the cables from the Mains switch to the line terminals. The cables have to be connected to the terminals L1, L2 and L3. <p>Note:</p> <ul style="list-style-type: none"> For single-phase version connect BLU cable to N and BROWN cable to L. |
| 6 | <ul style="list-style-type: none"> Fix the cables with the cable clamp. |

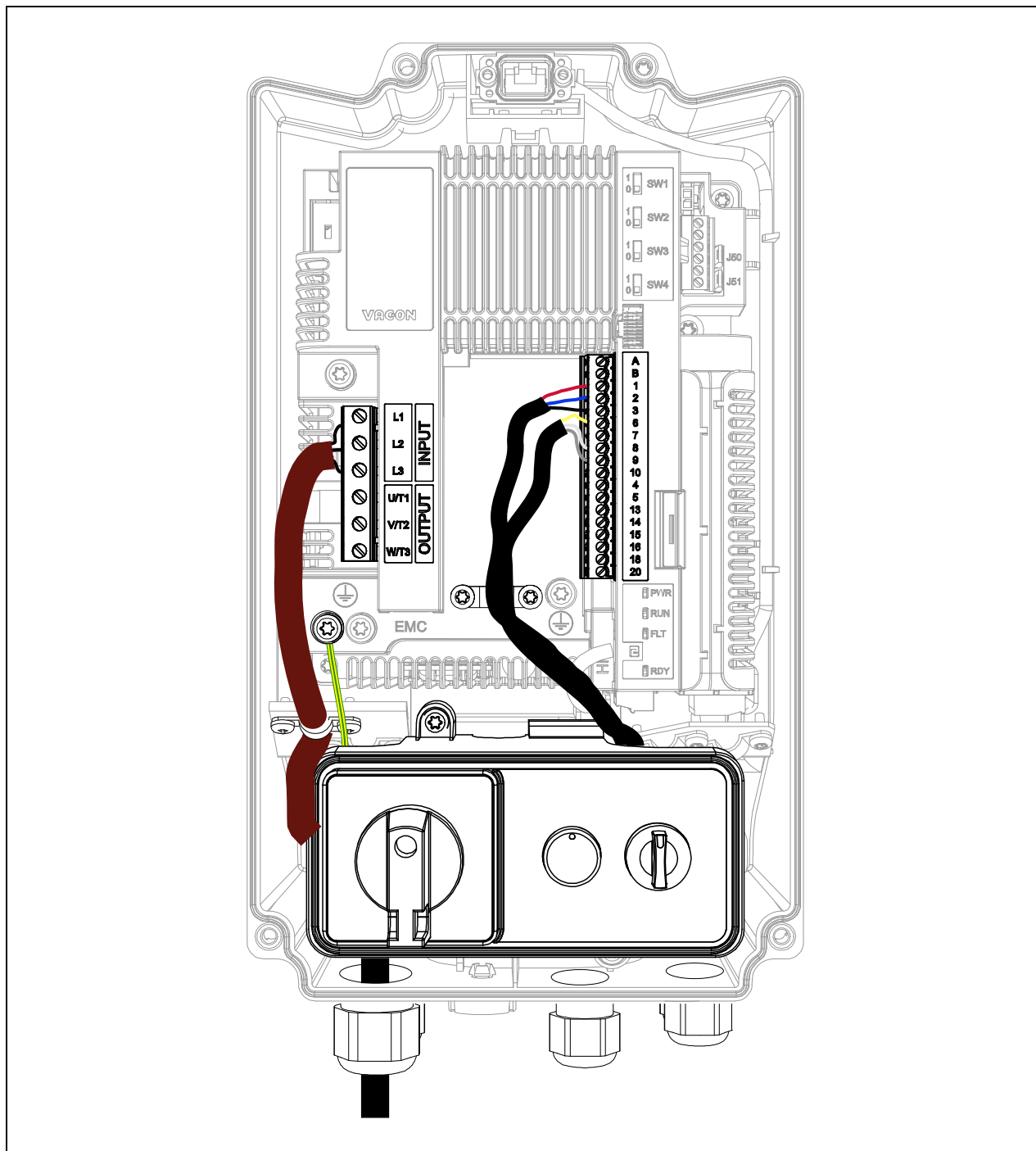
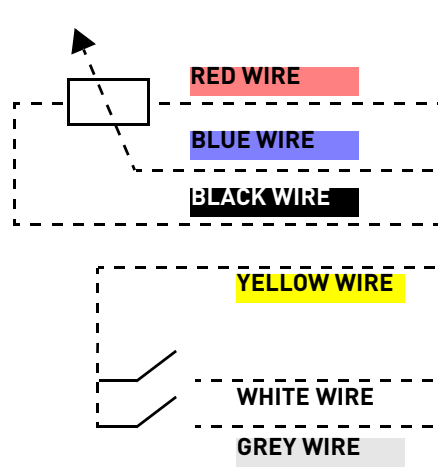

Figure 68. Simple operator panel connected (MU2 3-phase example).

| | |
|-----------|---|
| 7 | <ul style="list-style-type: none"> Connect the GROUND wire to the proper terminal (see the yellow-green cable on Figure 68). |
| 8 | <ul style="list-style-type: none"> Connect the cables from the potentiometer and from the selector to the I/O control terminals. The cables have to be connected to the I/O terminals as shown in the Figure 68 and in the Table 40. |
| 9 | <ul style="list-style-type: none"> RED, BLUE and BLACK wires are signals from the potentiometer. |
| 10 | <ul style="list-style-type: none"> YELLOW, WHITE and GREY wires are signal from the selector switch. |

Table 40. Control I/O terminal signal connections to the simple operator panel.



| Standard I/O terminals | | |
|------------------------|----------|------------------------------------|
| Terminal | Terminal | Signal |
| A | RS485_A | Serial bus, negative |
| B | RS485_B | Serial bus, positive |
| 1 | +10 Vref | Reference output |
| 2 | AI1+ | Analogue input, voltage or current |
| 3 | GND | I/O signal ground |
| 6 | 24Vout | 24V aux. voltage |
| 7 | DIN COM | Digital inputs common |
| 8 | DI1 | Digital input 1 |
| 9 | DI2 | Digital input 2 |
| 10 | DI3 | Digital input 3 |
| 4 | AI2+ | Analogue input, voltage or current |
| 5 | GND | I/O signal ground |
| 13 | DO1- | Digital output 1 common |
| 14 | DI4 | Digital input 4 |
| 15 | DI5 | Digital input 5 |
| 16 | DI6 | Digital input 6 |
| 18 | AO1+ | Analogue signal (+output) |
| 20 | DO1+ | Digital output 1 |

| Function | Description | Wire colors | Terminal |
|-----------------|-----------------------|-------------|----------|
| Potentiometer | 10V reference output | RED wire | 1 |
| | AI1+ | BLUE wire | 2 |
| | AI1- | BLACK wire | 3 |
| Switch selector | 24V auxiliary voltage | YELLOW wire | 6 |
| | digital input DI1 | WHITE wire | 8 |
| | digital input DI2 | GREY wire | 9 |

Table 41. Simple operator panel connection description.

11

- Mount the plastic cover onto the drive with its screws and the HMI cap: the installation process has been completed. See Figure 69.

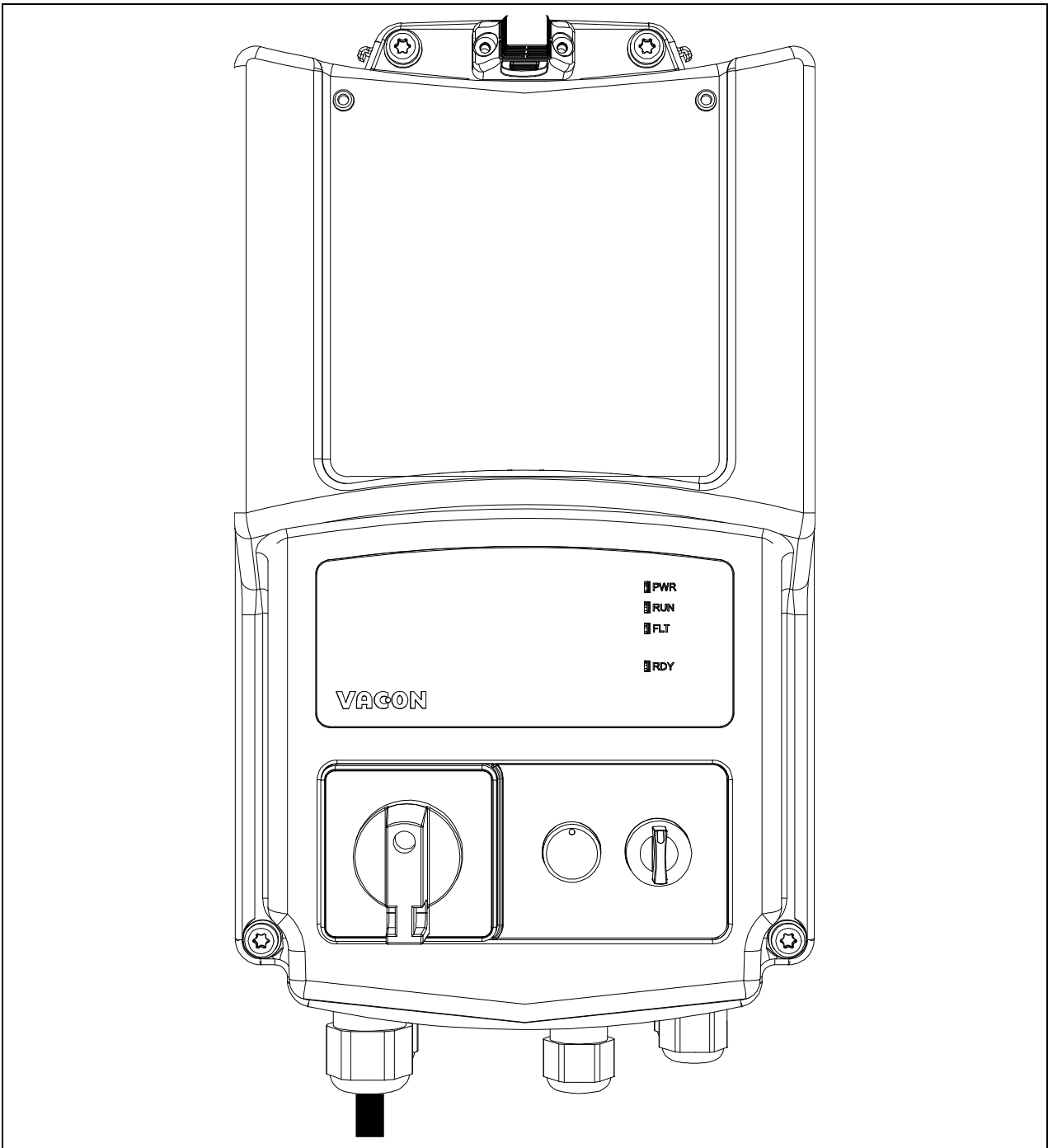

Figure 69. Mount the plastic cover.

9. SAFE TORQUE OFF









This chapter describes the Safe Torque Off (STO) function which is a functional safety feature present into VACON® 20 X drive products as standard. This function is available only in the three-phase version.

9.1 GENERAL DESCRIPTION

The STO function brings the motor in no-torque-state as defined by 4.2.2.2 of the IEC 61800-5-2: "Power that can cause rotation (or motion in the case of a linear motor) is not applied to the motor. The Power Drive System (Safety Related) will not provide energy to the motor which can generate torque (or force in the case of a linear motor)."

Therefore, the STO function is suitable for applications that rely on the immediate removal of power to the actuator, resulting in an uncontrolled coast to stop (activated by an STO demand). **Additional protective measures need to be applied when an application requires a different stop method.**

9.2 WARNINGS

| | |
|---|--|
|  | Designing of safety-related systems requires specialist knowledge and skills. Only qualified people are permitted to install and set up the STO function. The use of STO does not itself ensure safety. An overall risk evaluation is required for ensuring that the commissioned system is safe. Safety devices must be correctly incorporated into the entire system which must be designed in compliance with all relevant standards within the field of industry. |
|  | The information in this manual provides guidance on the use of the STO function. This information is in compliance with accepted practice and regulations at the time of writing. However, the end product/system designer is responsible for ensuring that the end-system is safe and in compliance with relevant regulations. |
|  | When a permanent magnet motor is used and in case of a multiple IGBT power semiconductor failure, when the STO option energizes the drive outputs to the off state, the drive system may still provide an alignment torque which maximally rotates the motor shaft by $180^\circ/p$ (where p is the number of poles of the motor) before the torque production ceases. |
|  | Electronic means and contactors are not adequate for protection against electric shock. The Safe Torque Off function does not disconnect the voltage or the mains from the drive. Therefore hazardous voltages may still be present on the motor. If electrical or maintenance work has to be carried out on electrical parts of the drive or the motor, the drive has to be completely isolated from the main supply, e.g. using an external supply disconnecting switch (see EN60204-1 section 5.3). |
|  | This safety function corresponds to an uncontrolled stop in accordance with stop category 0 of IEC 60204-1. The STO function does not comply with Emergency Switching Off according to IEC 60204-1 (no galvanic insulation from the Mains in case the motor is stopped). |
|  | The STO function is not a prevention of unexpected start-up. To fulfil those requirements, additional external components are required according to appropriate standards and application requirements. |
|  | In circumstances where external influences (e.g. falling of suspended loads) are present additional measures (e.g. mechanical brakes) may be necessary to prevent any hazard. |
|  | STO shall not be used as a control for starting or stopping the drive. |

9.3 STANDARDS

The STO function has been designed for use in accordance with the following standards:

| Standards |
|----------------------|
| IEC 61508, Parts 1-7 |
| EN 61800-5-2 |
| EN 62061 |
| ISO 13849-1 |
| EN 954-1 |
| IEC 60204-1 |

Table 42. Safety Standards.

The STO function has to be applied correctly to achieve the desired level of operational safety. Four different levels are allowed, depending on the use of the STO signals (see the following table).

| STO inputs | STO feedback | Cat. | PL | SIL |
|--------------------------|--------------|------|----|-----|
| Both dynamically used(*) | Used | 4 | e | 3 |
| Both statically used | Used | 3 | e | 3 |
| Connected in parallel | Used | 2 | d | 2 |
| Connected in parallel | Not used | 1 | c | 1 |

Table 43. Four different STO levels. (*) see 9.5.1.

The same values are calculated for SIL and SIL CL. According to EN 60204-1, the emergency stop category is 0.

The SIL value for the safety related system, operating in high demand/continuous mode, is related to the probability of dangerous failure per hour (PFH), reported in the following table.

| STO inputs | STO feedback | PFH | PFDav | MTTFd (years) | DCavg |
|--------------------------|--------------|--------------|----------|---------------|--------|
| Both dynamically used(*) | Used | 8.0 E-10 1/h | 7.0 E-05 | 8314 y | HIGH |
| Both statically used | Used | 8.1 E-10 1/h | 7.1 E-05 | 8314 y | MEDIUM |
| Connected in parallel | Used | 8.1 E-10 1/h | 7.1 E-05 | 8314 y | MEDIUM |
| Connected in parallel | Not used | 9.2 E-10 1/h | 8.0 E-05 | 8314 y | NONE |

Table 44. SIL values. (*) see 9.5.1.



The STO inputs must always be supplied by a safety device.

The power supply of the safety device may be external or taken from the drive (as long as this is compliant with the rating specified for terminal 6).

9.4 THE PRINCIPLE OF STO

The STO functionality, such as the technical principles and data (wiring examples and commissioning) will be described in this chapter.

In VACON® 20 X, the STO function is realized by preventing the propagation of the control signals to the inverter circuit.

The inverter power stage is disabled through redundant disabling paths which start from the two separated and galvanically isolated STO inputs (S1-G1, S2-G2 in Figure 70). In addition, an isolated output feedback is generated to improve the diagnostics of the STO function and to achieve a better safety capability (F+, F- terminals). The values assumed by the STO output feedback are indicated in the following table:

| STO inputs | Operating conditions | STO feedback output | Torque at the motor shaft |
|--------------------------------------|--|--------------------------|----------------------------------|
| Both inputs energized with 24V DC | Normal operation | The feedback must be 0V | present (motor on) |
| Power removed from both inputs | STO demand | The feedback must be 24V | disabled (motor de-energized) |
| The STO inputs have different values | Failure in demand or due to internal fault | The feedback must be 0V | disabled (motor de-energized)(*) |

Table 45. Values of the STO output feedback (and torque on the motor). (*) Only one channel is preventing the drive from moving.

The diagram below is a conceptual schematic diagram and is presented to illustrate the safety function with relevant safety components only shown.

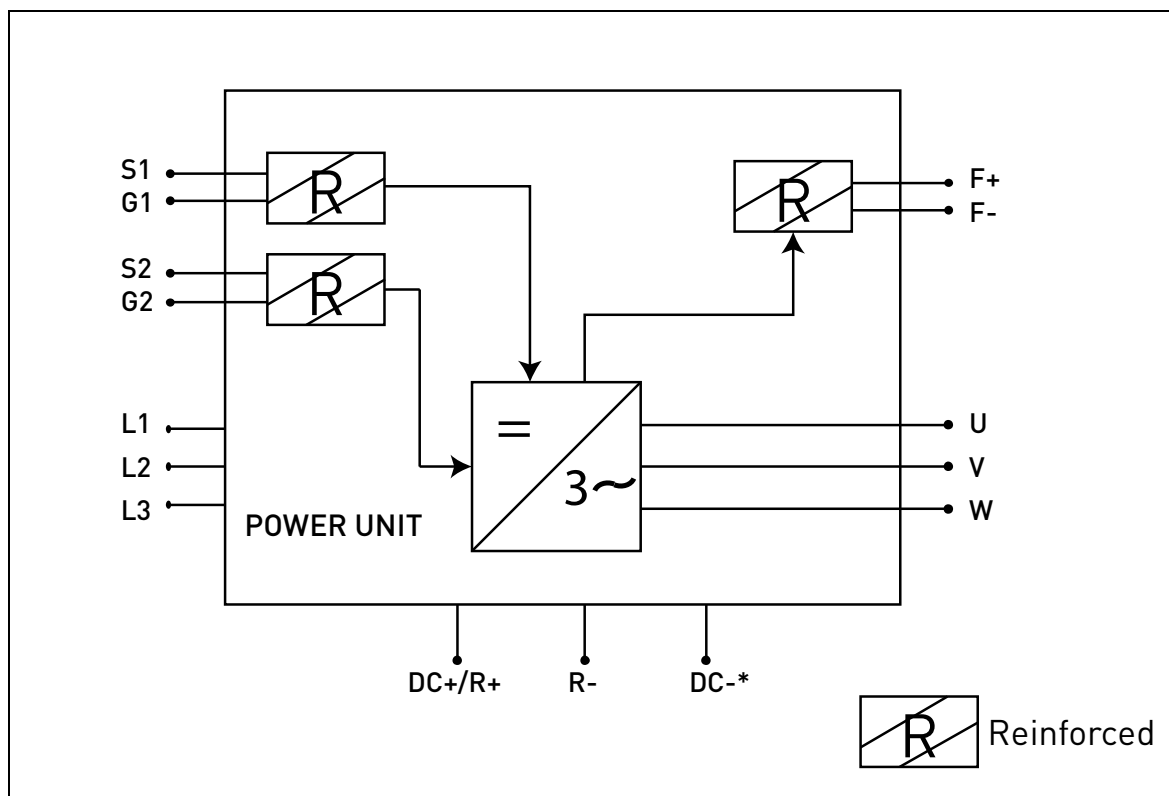

Figure 70. STO function principle. (*) Only for MU3.

9.4.1 TECHNICAL DETAILS

The STO inputs are digital inputs intended for a nominal 24V d.c. input, positive logic (e.g. enabled when high).

| Technical information: | Technical values |
|-----------------------------------|--|
| Absolute maximum voltage range | 24V \pm 20% |
| Typical input current at 24V | 10...15 mA |
| Logic threshold | according to IEC 61131-2 15V...30V = "1" 0V...5V = "0" |
| Response time at nominal voltage: | |
| Reaction time | <20ms |

Table 46. Electrical data.

The reaction time of the STO function is the amount of time which passes from the moment in which the STO is demanded until the system is in the Safe State. For VACON[®] 20 X, the reaction time is 20 ms maximum.

9.5 CONNECTIONS

To make the STO function available and ready to be used, both the STO jumpers have to be removed. They have been located in front of the STO terminal to mechanically prevent the insertion of the STO inputs. For the correct configuration, see the following table and the Figure 71.

| Signal | Terminal | Technical information | Data |
|-----------------|----------|--|-------------------|
| STO1 | S1 | Insulated digital input 1 (interchangeable polarity) | 24V \pm 20% |
| | G1 | | 10...15 mA |
| STO 2 | S2 | Insulated digital input 2 (interchangeable polarity) | 24V \pm 20% |
| | G2 | | 10...15 mA |
| STO feedback | F+ | Insulated digital output for STO feedback (CAUTION! Polarity must be respected) | 24V \pm 20% |
| | F- | | 15 mA max. GND |

Table 47. STO connector and data signals.

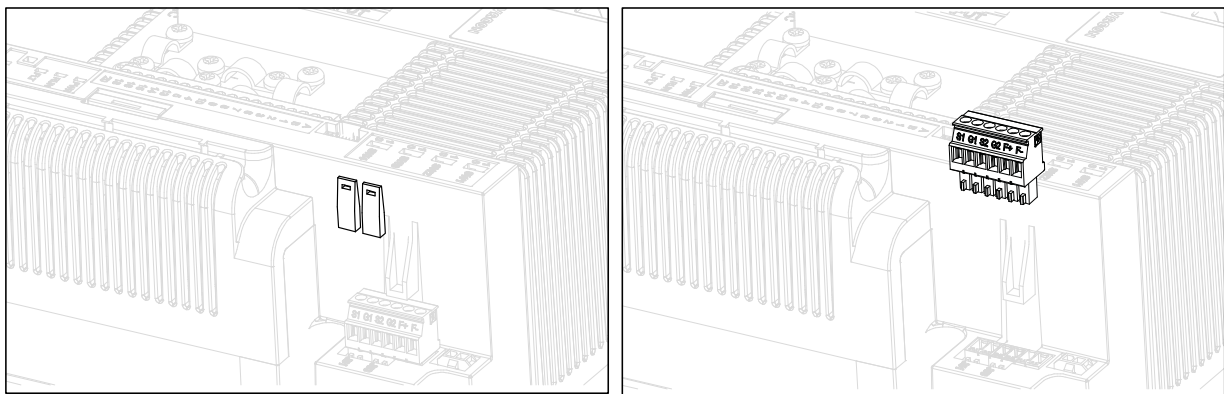

Figure 71. Removing the STO jumpers from the control unit.

| | |
|--|--|
| | Make sure that the frequency converter is switched off before cabling. |
| | When the STO function is used, the IP-class of the drive may not be reduced below IP54 . The IP-class of drive is IP66. It can be reduced by the wrong use of the cable entry plates or the cable glands. |
| | Disconnect both the STO jumpers to allow the cabling of the terminals. |

The following examples show the basic principles for wiring the STO inputs and the STO output feedback. Local standards and regulations should be always followed in the final design.

9.5.1 SAFETY CAPABILITY CAT.4 / PL e / SIL 3

For this safety capability, an external safety device must be installed. This must be used to dynamically activate the STO inputs and to monitor the STO output feedback.

The STO inputs are dynamically used when they do not commute together (static use), but according to the following picture (where the inputs are released with delay in turn). The dynamic use of the STO inputs allows detecting faults that may otherwise accumulate.

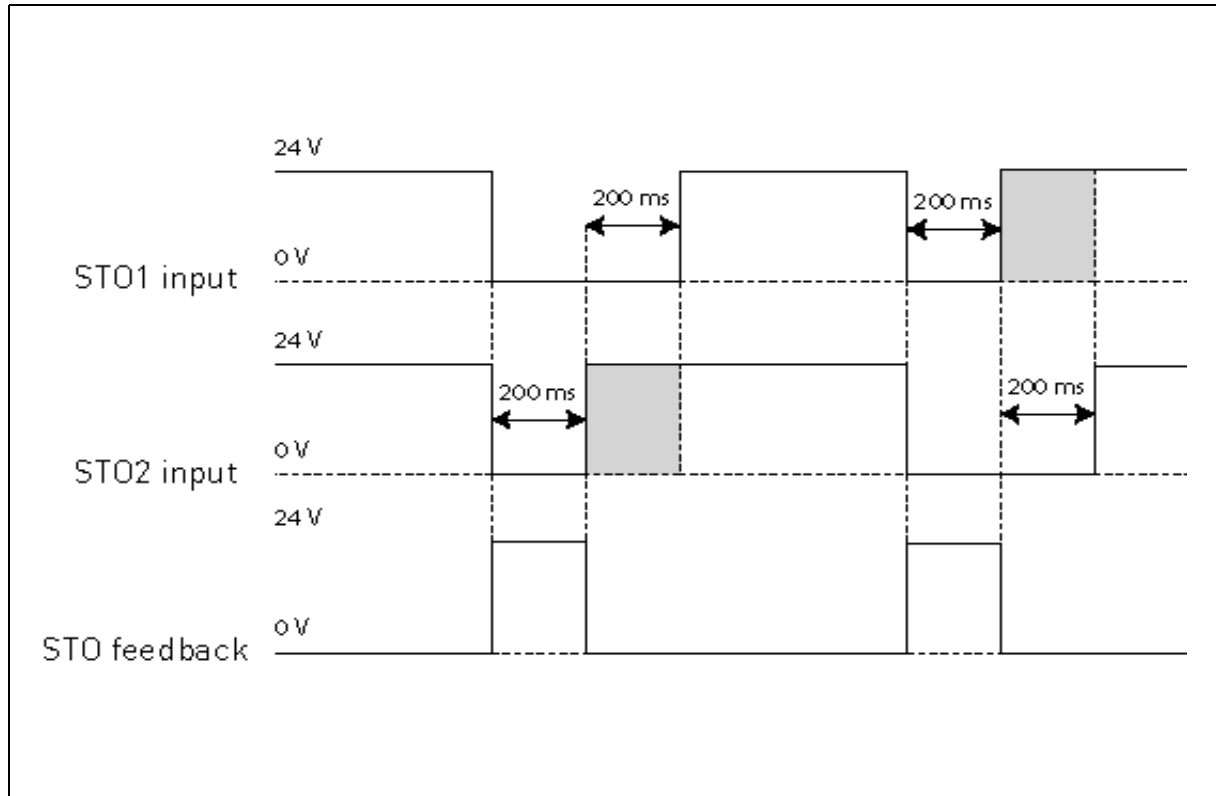

Figure 72.

| | |
|--|---|
| | <p>An emergency push button connected to the STO inputs does not assure the same quality, because no fault detection is performed at a sufficient frequency (once a day is recommended).</p> |
| | <p>The external safety device, which forces the STO inputs and evaluates the STO output feedback, has to be a safe device and it has to fulfil the requirements of the specific application.</p> |
| | <p>A simple switch cannot be used in this case!</p> |

The picture below shows an example of connection for the STO function. The external device has to be connected with 6 wires to the drive.

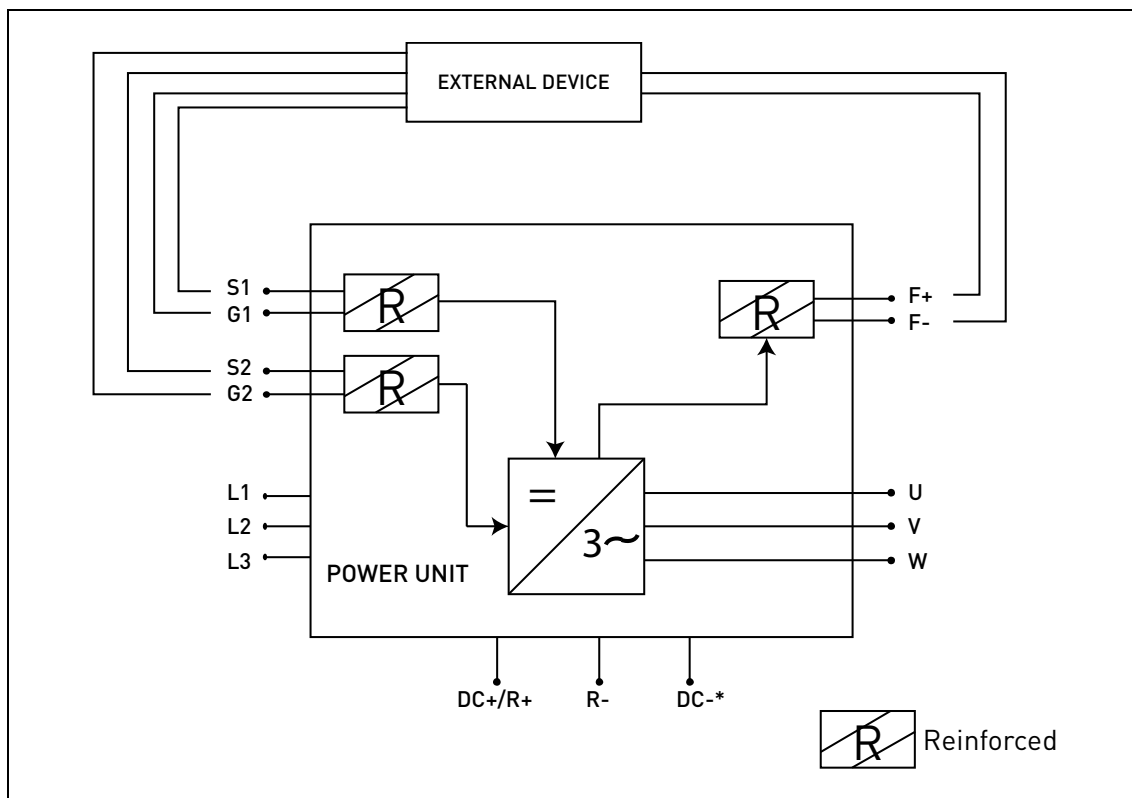

Figure 73. STO example with automatic monitoring of the feedback and both STO inputs used.
(*) Only for MU3.

The external device has to monitor the STO function in accordance with the Table 45. The device has to periodically de-energize the STO inputs and it has to verify that the STO output feedback assumes the expected value.

Any difference between the expected and the real value has to be considered as a failure and has to drive the system into a Safe State. In case of failure, check the wiring. If the fault recognized by the external safety device persists, **the drive will have to be replaced/repared.**

9.5.2 SAFETY CAPABILITY CAT. 3 / PL e / SIL 3

The safety capability is reduced to Cat. 3 / PL e / SIL 3 if the STO inputs are statically used (which means they are forced to commute together).

Both STO inputs and the STO feedback have to be used. The same warnings and cabling instruction as 9.5.1 apply.

9.5.3 SAFETY CAPABILITY CAT. 2 / PL d / SIL 2

The safety capability is reduced to Cat. 2 / PL d / SIL 2 if the STO inputs are connected in parallel (no redundancy of the STO inputs).

The STO feedback has to be used. The same warnings as 9.5.1 apply. The picture below shows an example of connection for the STO function. The external device has to be connected with 4 wires to the drive.

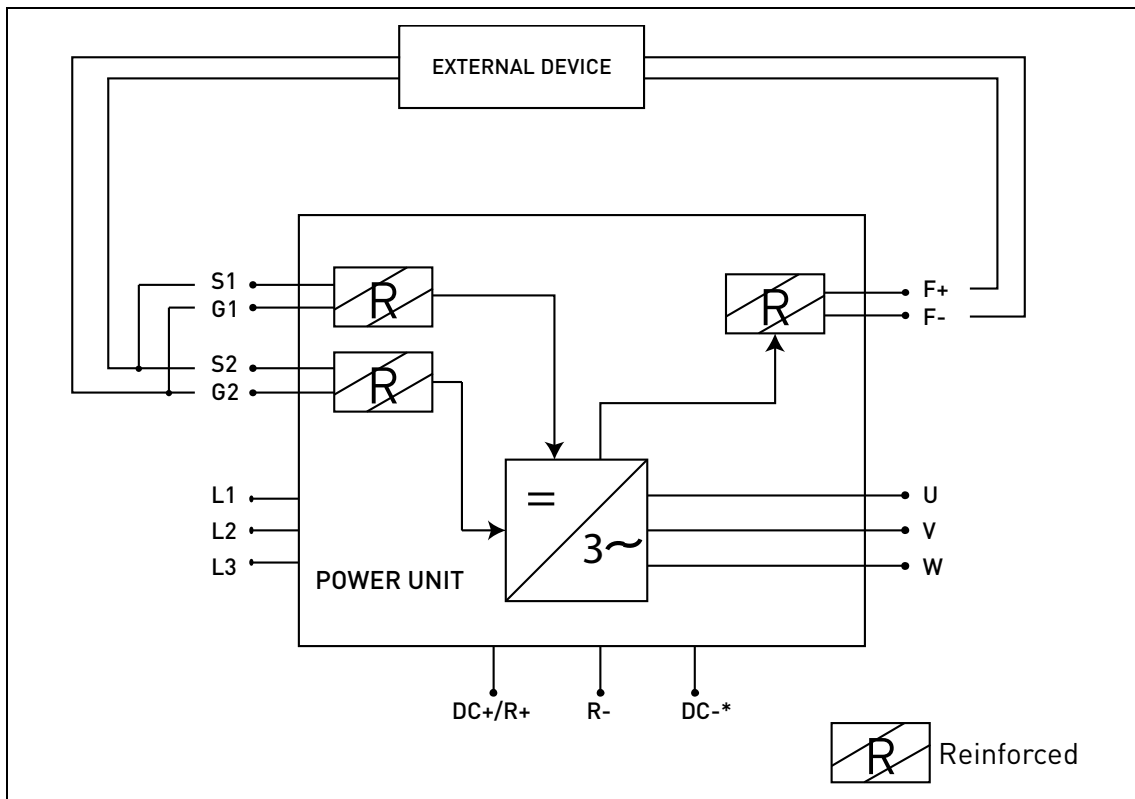





Figure 74. STO Example with automatic monitoring of the feedback and STO inputs connected in parallel. (*) Only for MU3.

9.5.4 SAFETY CAPABILITY CAT.1 / PL c / SIL 1

Without any automatic monitoring of STO output feedback, the safety capability is reduced to Cat. 1 / PL c / SIL 1. The STO inputs (which can be connected in parallel) must be supplied by a safety push button or a safety relay.

| | |
|---|--|
|  | The choice of using the STO inputs (without the automatic monitoring of the output feedback) does not allow the other safety capabilities to be achieved . |
|  | The standards for functional safety require that functional proof tests are performed on the equipment at user-defined intervals. Therefore, this safety capability can be achieved, as long as the STO function is manually monitored at the frequency determined by the specific application (once a month can be acceptable). |
|  | This safety capability can be achieved by connecting in parallel the STO inputs externally and by ignoring the use of the STO output feedback. |

The picture below shows an example of connection for the STO function. A switch (a safety push button or a safety relay) may be connected with 2 wires to the drive.

When the contacts of the switch are opened, the STO is demanded, the drive indicates F30 (=“Safe Torque Off”) and the motor stops by coasting.

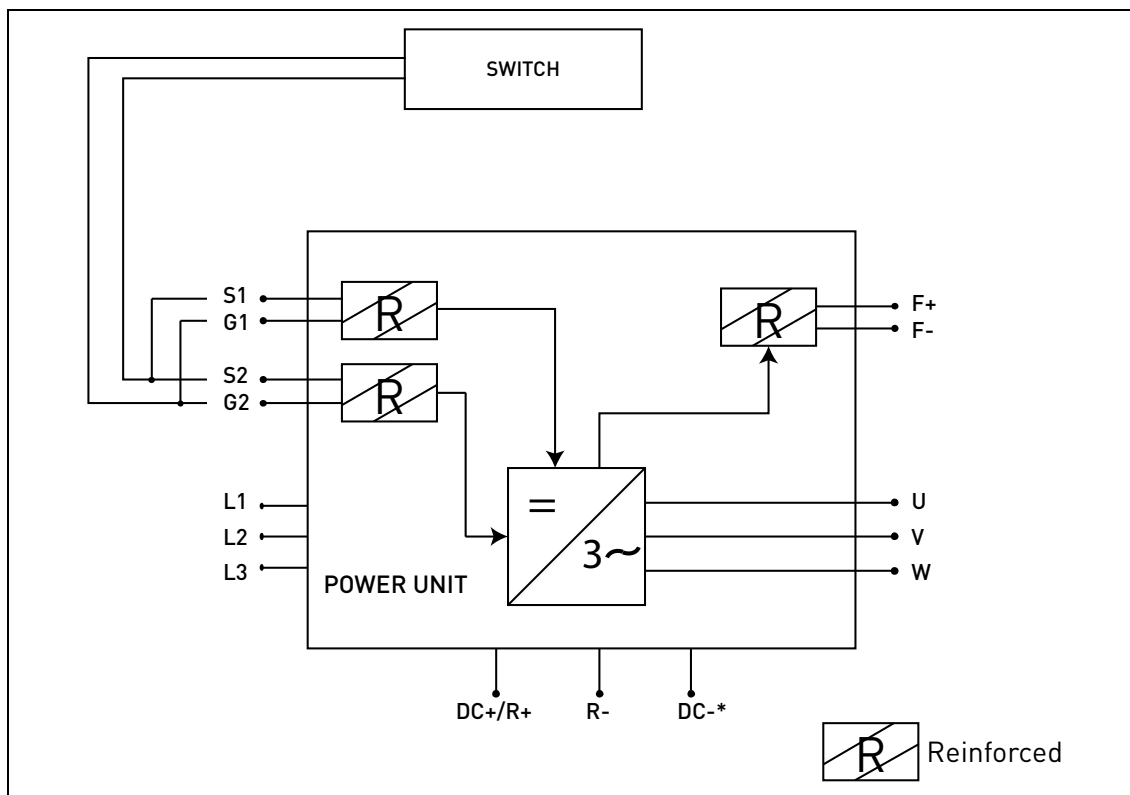



Figure 75. STO example without automatic monitoring of the feedback and STO inputs connected in parallel. (*)Only for MU3.

9.6 COMMISSIONING

9.6.1 GENERAL WIRING INSTRUCTIONS

| | |
|---|--|
|  | Protect the STO cabling with a shielding or an enclosure to exclude external damage. |
|  | Wires ferrules are highly recommended for all STO signals (inputs and feedback). |

The wiring should be done according to the general wiring instructions for the specific product. A shielded cable is required. In addition, the voltage drop from the supply point to the load shall not exceed 5% [EN 60204-1 part 12.5].

The following table indicates examples of cables to be used.

| STO feedback | Cable size |
|---|---------------------------------------|
| STO feedback automatically monitored by an external safety device | 3 x (2 + 1) x 0,5 mm ² (*) |
| STO feedback ignored, simply safety device (switch) used | 2 x (2 + 1) x 0,5 mm ² |

Table 48. Cable types required to meet the standards. (*) Additional wires are needed for restarting the drive after each STO demand.

9.6.2 CHECKLIST FOR COMMISSIONING



Follow the checklist shown in the table below for steps required to use the STO function.

| | |
|--------------------------|---|
| <input type="checkbox"/> | Carry out a risk assessment of the system to ensure that the use of the STO function is safe and according to the local regulations |
| <input type="checkbox"/> | Include in the assessment an examination of whether the use of external devices, such as a mechanical brake, are required. |
| <input type="checkbox"/> | Check if the switch (if used) has been chosen according to the required safety performance target (SIL/PL/Category) set during the risk evaluation |
| <input type="checkbox"/> | Check if the external device for automatic monitoring of the STO output feedback (if used) has been chosen in accordance with the specific application |
| <input type="checkbox"/> | Check if the reset function with the STO function (if used) is edge sensitive. |
| <input type="checkbox"/> | The shaft of a permanent magnet motor might, in an IGBT fault situation, still provide energy before the torque production ceases. This may result in a jerk of max. 180° electrically. Ensure that the system is designed in such a way that this can be accepted. |
| <input type="checkbox"/> | Check if the degree of protection of the enclosure is at least IP54 . See paragraph 9.5. |
| <input type="checkbox"/> | Check if the recommendations on EMC for cables have been followed. |
| <input type="checkbox"/> | Check if the system has been designed in such a way that enabling of the drive through STO inputs will not lead to an unexpected start of the drive |
| <input type="checkbox"/> | Check if only approved units and parts have been used. |
| <input type="checkbox"/> | Set up a routine to ensure that the functionality of the STO function is being checked at regular intervals. |

Table 49. Checklist for commissioning of STO.

9.7 PARAMETERS AND FAULT TRACING



There are no parameters for the STO function itself.

| | |
|---|--|
|  | Before testing the STO function, make sure that the checklist (Table 49) is inspected and completed. |
|  | When STO function is demanded, the drive always generates a fault ("F30") and the motor stops by coasting. |
|  | In the application the STO state can be indicated using a digital output. |

To re-enable motor operation, after the STO state, it is necessary to perform the following steps:

- Release the switch or the external device ("F30" is displayed even after this has been released).
- Reset the fault (through a digital input or from the keypad).
- It is possible that a new start command is required for the restart (depending on the application and your parameter settings).

9.8 MAINTENANCE AND DIAGNOSTICS

| | |
|---|---|
|  | If any service or repair has to be conducted on the drive installed, please inspect the checklist given in Table 49. |
|  | During maintenance breaks, or in case of service/repair, ALWAYS make sure that the STO function is available and fully functional by testing it. |

The STO function or the STO input/output terminals do not need any maintenance.

The following table shows faults that may be generated by the software that monitors the hardware related to the STO safety function. If you detect any failure in safety functions, including STO, contact your local Vacon supplier.

| Fault Code | Fault | Cause | Correction |
|------------|-----------|--|---------------|
| 30 | STO fault | STO inputs in a different state or both de-energized | Check cabling |

Table 50. Fault related to the STO function.

VACON[®]

DRIVEN BY DRIVES

Find your nearest Vacon office
on the Internet at:

www.vacon.com



Manual authoring:
documentation@vacon.com

Vacon Plc.
Runsorintie 7
65380 Vaasa
Finland

Subject to change without prior notice
© 2015 Vacon Plc.

Document ID:



Order code:



Rev. F