



UNIDRIVE M400



Manufacturing Automation drive

Fast set-up and diagnosis with real-text display, plus integrated CODESYS based PLC for open loop applications



- Unidrive M100
- Unidrive M200
- Unidrive M300
- Unidrive M400**
- Unidrive M600
- Unidrive M700
- Unidrive M800

0.25 kW - 110 kW Heavy Duty
(0.33 hp - 150 hp)
100 V | 200 V | 400 V | 575 V | 690 V





The Unidrive M Manufacturing Automation drive family

Unidrive M – A Manufacturing Automation drive family tailored to customer needs

Led by the results of extensive customer-driven market research, we have tailored seven Unidrive M feature-sets to specific application needs identified within Manufacturing Automation. The Unidrive M400 adds to the family an optional enhanced LCD keypad, precise frequency following and onboard Programmable Logic Control (PLC) for open loop applications. It also provides an easy upgrade for existing Commander SK high power applications or where a programmable LogicStick is used.

For more information on the full Unidrive M family, please download the Unidrive M Overview brochure or the 'Discover Unidrive M' App (available on the App Store, Android and online) via www.UnidriveM.com.



Unidrive M400 features

Optional AI-485 Adaptor for RS485 communications

Optional AI-Back-up Adaptor allows the drive to use an SD card for parameter cloning and acts as an input for 24 V back-up

Optional CI-Keypad - intuitive plain text multilingual back-lit LCD keypad for rapid set-up and superior diagnostics

Optional IP66 Remote Keypad available for flexible mounting

Drive rated to IP21 / UL open class (NEMA 1) on size 1 to 4 as standard

Conduit kits are available to meet UL Type 1 rating

Easy-to-remove terminal cover with tool-less close system (patent pending)

Typical System Integration (SI) option module

Power-on / Drive status LED

Dual onboard Safe Torque Off (STO) terminals for easy SIL3 conformity

Conventional surface and DIN rail mounting (DIN rail mounting available on size 1 and 2 only)

User-friendly control connections

Easy-to-disconnect internal EMC filter*

User-friendly power connections*

Robust cable management system providing grounding point for shielded control and power cables

System Integration (SI) module slot for optional communications and additional I/O



* Features and their locations vary on some drive sizes

Unidrive M400 AC drive at a glance

Fast set-up and diagnosis with real-text display, plus integrated CODESYS based PLC

M400 minimizes machine downtime with its optional intuitive advanced LCD keypad that offers real-text multi-language display for rapid set-up and superior diagnostics. Its onboard PLC with real-time tasking can be used for simple logic control using Machine Control Studio programming software (powered by CODESYS) to enhance drive application capability.

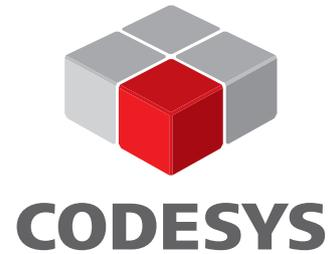

Maximize productivity with high performance control of AC motors

Unidrive M400's advanced Rotor Flux Control (RFC) algorithm ensures maximum stability and machine control. It provides a high bandwidth motor control algorithm with 166 μ s current loop update rates and 180 % motor overload for heavy industrial machinery applications.

Maximize throughput and easily meet machine safety requirements

Unidrive M400 has onboard dual Safe Torque Off (STO) inputs for easy safety system integration, eliminating external components such as contactors. Compliance with SIL3 is simple while machine productivity is enhanced.

Robust design

After extensive customer research, Unidrive M400 has been designed and tested for leading reliability in manufacturing environments. It features:

- Unique advanced cooling design featuring a patented flow system that helps cool the drive more effectively while protecting internal components

- Conformally coated PCBs
- 180 % overload for 3 s or 150 % for 60 s
- Wide supply voltage tolerance
- Drive meets IP21 as standard
- Higher temperature operation with de-rating
- Intelligent 3 speed user-replaceable cooling fan with patented fan-fail detection circuit

Fast parameter transfer without mains power

For fast, serial machine production the AI-Back-up Adaptor option plugs into the top of the drive to allow configuration settings and Machine Control Studio programs (powered by CODESYS) to be copied without the need to apply mains power. Files are stored on an SD memory card for easy handling.



Enhance productivity through easy integration with automation systems and reduce machine downtime

Unidrive M400 provides optional RS485 communications and a port for a System Integration (SI) option module. SI modules include Ethernet, EtherCAT, PROFIBUS, DeviceNet and CANopen network communications, and additional I/O. These allow remote control and diagnostics across different networks, while I/O can be configured to accept an encoder or frequency/direction inputs for frequency following.

Reduce machine size and cost

Unidrive M400's compact drive dimensions are among the smallest in class at every power rating. Packed full of onboard features, such as programmable automation for simple applications and 2 x STO terminals, Unidrive M400 provides a powerful economical solution, eliminating the need for many external components such as PLCs and safety contactors.

Easy to access machine control features

Our software tools, keypads and memory storage devices provide easy and fast access to Unidrive M's machine control features for configuration, monitoring and diagnostics.

Powerful and easy field service and upgrade

The M400 is designed to extend the field service life of previous generations of products. It also provides the easiest possible upgrade for OEM machine designs that currently use Commander SK drives in high power applications or where a LogicStick is used. Features include:

- Compatible dimensions
- Onboard programming
- Extended power ratings up to 110 kW (150 hp)
- Support for the import of Commander SK parameter files and drive cloning

Typical applications:

Speed control for conveyors, positive displacement pumps, material transport and cutting, woodworking and where fast set-up and diagnostics are required.



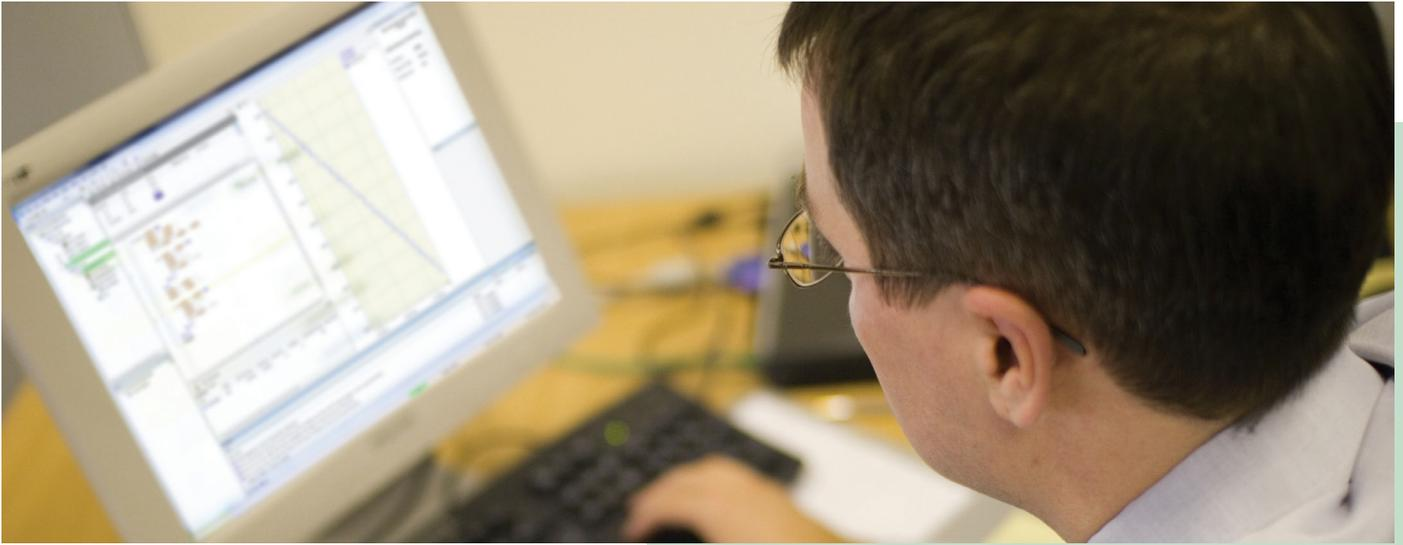

Machine Control Studio programming software powered by CODESYS



Control Techniques' Machine Control Studio software provides a flexible and intuitive environment for programming Unidrive M's new automation and motion control features. This new software offers programming for the Unidrive M400's onboard PLC.

Machine Control Studio is powered by CODESYS, the leading open software for programmable machine control. The programming environment is fully EN/IEC 61131-3 compliant, meaning that it is familiar and therefore fast and easy to use for control engineers around the world.

The following EN/IEC 61131-3 programming languages are supported:

- Structured Text (ST)
- Function Block Diagram (FBD)
- Structured Function Chart (SFC)
- Ladder Diagram (LD)
- Instruction List (IL)

Also supported:

- Continuous Function Chart (CFC)

Intuitive IntelliSense functionality helps to write consistent and robust programming, speeding up software development. Programmers have access to a vibrant open-source community

for function blocks. Control Techniques also provides support for customers' own function block libraries, with on-line monitoring of program variables with user defined watch windows and help for on-line change of program, in line with current PLC practices.

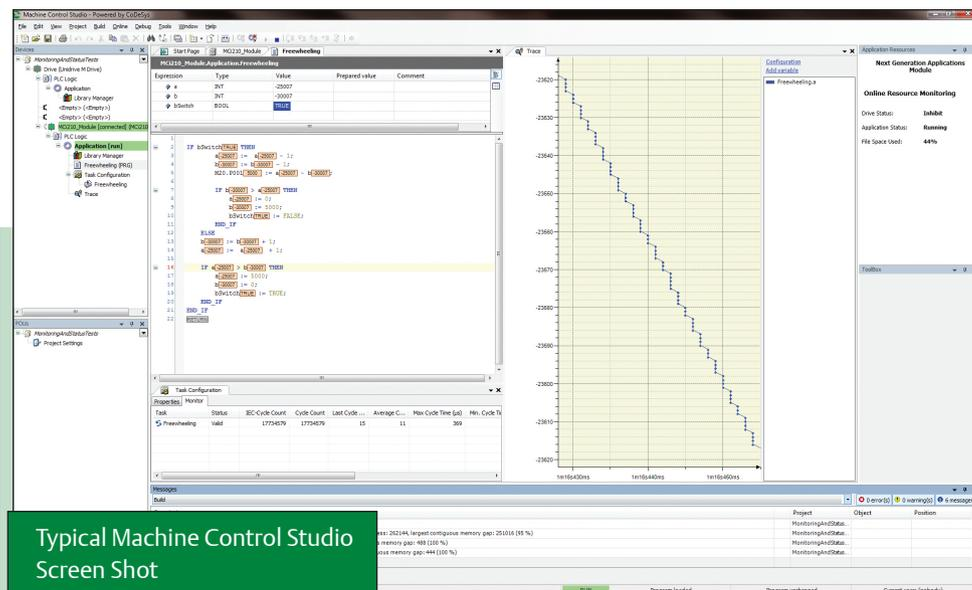

Typical Machine Control Studio Screen Shot



Coating line application

Power System Flexibility

Unidrive M's power stage enhances flexibility and energy efficiency:

- Low losses, up to 98 % efficient.
- Low power standby mode. In some applications, drives can sit idle for significant periods; M400's reduced standby power saves energy.
- Intelligently controlled 3-speed cooling fan adjusts to the motor load and environmental conditions. This results in power saving, extended fan life and reduced acoustic noise.
- Silent motor operation with high PWM switching frequencies up to 16 kHz.

Motor control modes include:

Control Mode	Features
Open loop vector or V/Hz induction motor control	Open loop motor control for induction motors, providing good performance and the easiest configuration. V/Hz can be used in multi-motor systems.
Enhanced open loop Rotor Flux Control for induction motors (RFC-A)	High performance speed and torque control through an advanced vector algorithm, utilizing current feedback to greatly enhance performance for all induction motor sizes without the need for a feedback device.

Unidrive M400 option choices and terminal layout

Control Mode

1. Open loop vector or V/Hz induction motor control
2. Open loop Rotor Flux Control for induction motors (RFC-A)



Optional Drive Programming and Operator Interface

Unidrive M Connect



CI-Keypad



Remote Keypad



Operator Interface



AI-Back-up Adaptor
(provides SD card usage)



Input/Output

SI-I/O



- 4 x Digital I/O
- 3 x Analog input (default) / Digital input
- 1 x Analog output (default) / Digital input
- 2 x Relay

Standard



- 4 x Analog I/O
- 7 x Digital I/O
- 2 x STO
- 1 x Relay (size 1 to 4)
- 2 x Relay (size 5 to 9)

DC back up power supply

AI-Back-up Adaptor
(Input for 24 V back-up)





Applications with PLC Functionality

Standard

Easy to use onboard PLC using industry standard CODESYS programming environment



Communications

AI-485 Adaptor



SI-EtherCAT



SI-PROFIBUS



SI-Ethernet



CI-485 Adaptor



SI-DeviceNet



SI-CANopen



SI-PROFINET



Terminal Layout

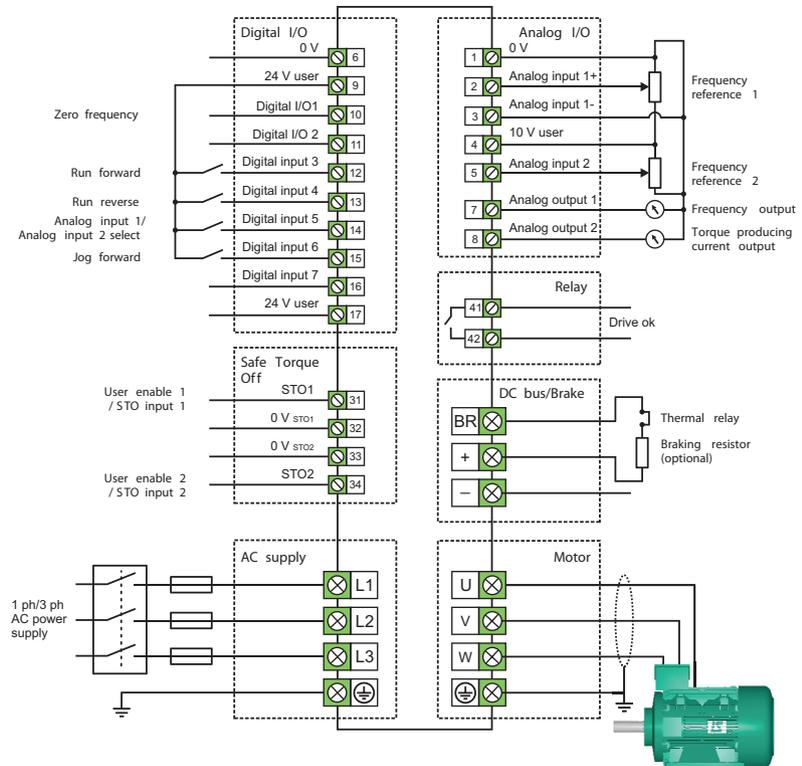



Typical woodworking application

Fast and Easy access for Commissioning, Monitoring and Diagnostics

Unidrive M keypads, memory devices and software tools make it easy to access Unidrive M400's full feature set, allowing users to optimize drive tuning, back-up the configuration set and troubleshoot more quickly.

User interface options

Unidrive M benefits from two optional keypad choices to meet your application needs.

Type		Benefit
CI-Keypad		Intuitive plain text, multi-language LCD keypad for rapid set-up and superior diagnostics maximizes machine up-time. Innovative clipless fit provides easy removal.
Remote Keypad		All the features of the CI-Keypad LCD, but remote mountable (using the AI-485 or CI-485 Adaptor along with a common comms lead). This allows flexible mounting on the outside of a panel and meets IP66 (NEMA 4).

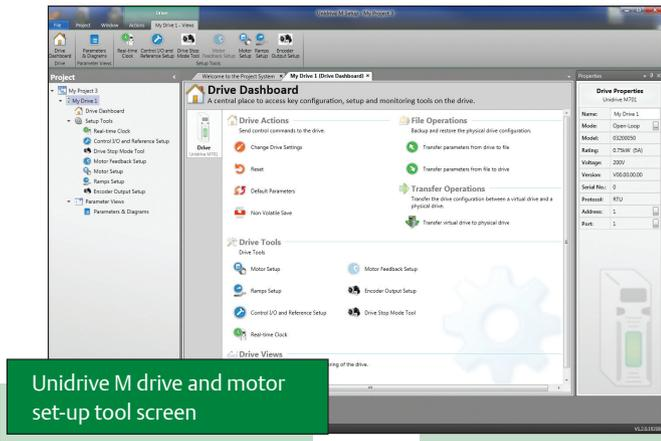

Unidrive M Connect commissioning tool

Based on Control Techniques' 25 years of experience, Unidrive M Connect is our latest drive configuration tool for commissioning, optimizing and monitoring drive/system performance. Its development draws from extensive user research, using human centered design principles to give the ultimate user experience:

- Fast task based commissioning and easy maintenance of the Unidrive M family is simplified via familiar Windows interface
- Intuitive graphical tools enhance and simplify user experience
- For experienced users, dynamic drive logic diagrams and enhanced searchable listings are present
- Drive and motor performance can be optimized with minimal specialized drive knowledge
- Tool is scalable to match application requirements
- Supports the import of Commander SK parameter files and allows full drive cloning (i.e. parameter sets and application program)
- Multiple simultaneous communications channels for a more complete overview of the system
- Drive discovery gives the ability to find drives on a network automatically without the user having to specify their addresses
- Automatic RTU baud rate scanning on the M400 RS485 connection

Portable SD memory card

Unidrive M400 uses popular SD cards for quick and easy parameter and program storage using the AI-Back-up Adaptor. SD cards provide a huge memory capability allowing a complete system reload if required and can be easily pre-programmed on a common PC.

Performance motor control

Control Techniques' unique motor control algorithms combined with the latest microprocessor technology ensure that Unidrive M400 offers high stability and bandwidth for many industrial motor types. This enables you to maximize machine throughput and efficiency in every application using open loop AC induction motors.

Unidrive M400 feature and specification table

Performance	Current loop update: 166 μ s
	Heavy Duty peak rating: 180 % (3 s), 150 % (60 s)
	Maximum output frequency: 550 Hz
	Switching frequency range: 0.67, 1, 2, 3, 4, 6, 8, 12, 16 kHz (3 kHz default)
Onboard intelligence	Programmable Logic Control (PLC) - memory: 8 kB
	1 x Real-time task (16ms), 1 x Background task
Mechanical attributes	DIN rail mountable (size 1 and 2)
	Commander SK compatible mechanical footprint either as standard or with conversion plates
Parameter back-up	Serial port cloning (using optional AI-485 Adaptor or CI-485 Adaptor)
	SD card (using optional AI-Back-up Adaptor)
Feedback	Encoder Input 1
Onboard I/O	2 x Analog inputs, 2 x Analog outputs
	5 x Digital inputs, 2 x Bidirectional digital inputs or outputs
	1 x Relay output (size 1 to 4), 2 x Relay outputs (size 5 to 9)
Machine safety	2 x Safe Torque Off (STO) inputs
Back-up power	24 V control back-up (using optional AI-Back-up Adaptor)
Other	Temperature controlled fan with standby (off)
	User replaceable fan(s)
	Conformal coating
	Standby mode (energy saving)
	User defined security levels (e.g. restricted access or read-only parameters via user defined security code)

Unidrive M400 ratings and specifications

100/120 Vac ±10 %							
Order Code	Supply Phases	Heavy Duty			Normal Duty		
		Max Continuous Current (A)	Motor Shaft Power (kW)	Motor Shaft Power (HP)	Max Continuous Current (A)	Motor Shaft Power (kW)	Motor Shaft Power (HP)
M400-011 00017	1	1.7	0.25	0.33	For Normal Duty applications, use Heavy Duty ratings.		
M400-011 00024	1	2.4	0.37	0.5			
M400-021 00042	1	4.2	0.75	1			
M400-021 00056	1	5.6	1.1	1.5			

200/240 Vac ±10 %										
Order Code	Supply Phases	Heavy Duty			Normal Duty					
		Max Continuous Current (A)	Motor Shaft Power (kW)	Motor Shaft Power (HP)	Max Continuous Current (A)	Motor Shaft Power (kW)	Motor Shaft Power (HP)			
M400-012 00017	1	1.7	0.25	0.33	For Normal Duty applications, use Heavy Duty ratings.					
M400-012 00024	1	2.4	0.37	0.5						
M400-012 00033	1	3.3	0.55	0.75						
M400-012 00042	1	4.2	0.75	1						
M400-022 00024	1/3	2.4	0.37	0.5						
M400-022 00033	1/3	3.3	0.55	0.75						
M400-022 00042	1/3	4.2	0.75	1						
M400-022 00056	1/3	5.6	1.1	1.5						
M400-022 00075	1/3	7.5	1.5	2						
M400-032 00100	1/3	10	2.2	3						
M400-042 00133	1/3	13.3	3	3						
M400-042 00176	3	17.6	4	5						
M400-052 00250	3	25	5.5	7.5				30	7.5	10
M400-062 00330	3	33	7.5	10				50	11	15
M400-062 00440	3	44	11	15	58	15	20			
M400-072 00610	3	61	15	20	75	18.5	25			
M400-072 00750	3	75	18.5	25	94	22	30			
M400-072 00830	3	83	22	30	117	30	40			
M400-082 01160	3	116	30	40	149	37	50			
M400-082 01320	3	132	37	50	180	45	60			
M400-092 01760	3	176	45	60	216	55	75			
M400-092 02190	3	219	55	75	266	75	100			

380/480 Vac ±10 %							
Order Code	Supply Phases	Heavy Duty			Normal Duty		
		Max Continuous Current (A)	Motor Shaft Power (kW)	Motor Shaft Power (HP)	Max Continuous Current (A)	Motor Shaft Power (kW)	Motor Shaft Power (HP)
M400-024 00013	3	1.3	0.37	0.5	For Normal Duty applications, use Heavy Duty ratings.		
M400-024 00018	3	1.8	0.55	0.75			
M400-024 00023	3	2.3	0.75	1			
M400-024 00032	3	3.2	1.1	1.5			
M400-024 00041	3	4.1	1.5	2			
M400-034 00056	3	5.6	2.2	3			
M400-034 00073	3	7.3	3	3			
M400-034 00094	3	9.4	4	5			
M400-044 00135	3	13.5	5.5	7.5			
M400-044 00170	3	17	7.5	10			
M400-054 00270	3	27	11	20	30	15	20
M400-054 00300	3	30	15	20	30	15	20
M400-064 00350	3	35	15	25	38	18.5	25
M400-064 00420	3	42	18.5	30	48	22	30

M400-064 00470	3	47	22	30	63	30	40
M400-074 00660	3	66	30	50	79	37	50
M400-074 00770	3	77	37	60	94	45	60
M400-074 01000	3	100	45	75	112	55	75
M400-084 01340	3	134	55	100	155	75	100
M400-084 01570	3	157	75	125	184	90	125
M400-094 02000	3	200	90	150	221	110	150
M400-094 02240	3	224	110	150	266	132	200

500/575 Vac ± 10 %							
Drive	Supply Phases	Heavy Duty			Normal Duty		
		Max Continuous Current (A)	Typical Output (kW)	Motor Power (HP)	Max Continuous Current (A)	Typical Output (kW)	Motor Power (HP)
M400-055 00030 A	3	3	1.5	2	3.9	2.2	3
M400-055 00040 A	3	4	2.2	3	6.1	4	5
M400-055 00069 A	3	6.9	4	5	10	5.5	7.5
M400-065 00100 A	3	10	5.5	7.5	12	7.5	10
M400-065 00150 A	3	15	7.5	10	17	11	15
M400-065 00190 A	3	19	11	15	22	15	20
M400-065 00230 A	3	23	15	20	27	18.5	25
M400-065 00290 A	3	29	18.5	25	34	22	30
M400-065 00350 A	3	35	22	30	43	30	40
M400-075 00440 A	3	44	30	40	53	45	50
M400-075 00550 A	3	55	37	50	73	55	60
M400-085 00630 A	3	63	45	60	86	75	75
M400-085 00860 A	3	86	55	75	108	90	100
M400-095 01040 A	3	104	75	100	125	110	125
M400-095 01310 A	3	131	90	125	150	110	150

500/690 Vac ± 10 %							
Drive	Supply Phases	Heavy Duty			Normal Duty		
		Max Continuous Current (A)	Typical Output (kW)	Motor Power (HP)	Max Continuous Current (A)	Typical Output (kW)	Motor Power (HP)
M400-076 00190 A	3	19	15	20	23	18.5	25
M400-076 00240 A	3	24	18.5	25	30	22	30
M400-076 00290 A	3	29	22	30	36	30	40
M400-076 00380 A	3	38	30	40	46	37	50
M400-076 00440 A	3	44	37	50	52	45	60
M400-076 00540 A	3	54	45	60	73	55	75
M400-086 00630 A	3	63	55	75	86	75	100
M400-086 00860 A	3	86	75	100	108	90	125
M400-096 01040 A	3	104	90	125	125	110	150
M400-096 01310 A	3	131	110	150	150	132	175

See overleaf for Normal Duty and Heavy Duty definitions.

Key:

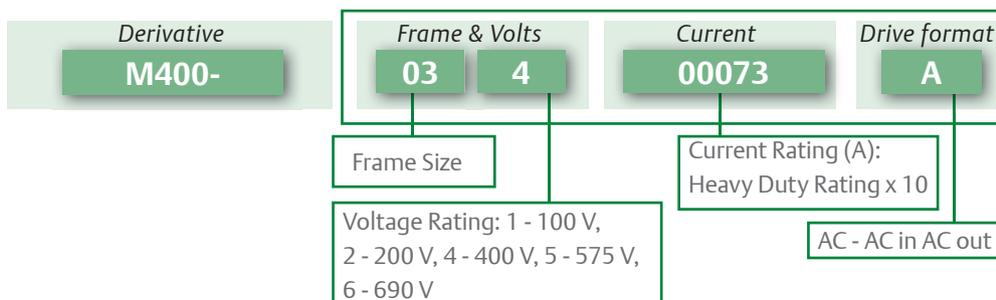

Unidrive M400 ratings and specifications

Heavy Duty

Suitable for demanding applications, current overload of 180 % (3 s) is available for dynamic loads.

Normal Duty

Suitable for most applications, with a current overload capacity of 110 %.

Environmental safety and electrical conformance

- Size 1 to 4: IP21 / UL open class (NEMA 1).
IP20 when the AI-Back-up or AI-485 Adaptors are fitted.
UL TYPE 1 compliance requires the appropriate Conduit kit to be fitted.
- Size 5 to 9: IP20 / UL open class (NEMA 1).
UL TYPE 1 compliance requires the appropriate Conduit kit to be fitted.
IP65 / UL TYPE 12 rating is achieved on the rear of the drive when through panel mounted.
- Ambient temperature -20 °C (-4 °F) to 40 °C (104 °F) as standard. Up to 60 °C (140 °F) with derating.
- Storage temperature -40 °C to 60 °C (-40 °F to 140 °F).
- Humidity 95 % maximum (non-condensing) at 40 °C (104 °F) in accordance with EN/IEC 60068-2-78 and ANSI/EIA-364-31.
- EN/IEC 60068-2-60, Method 4 Corrosive gas.
- Altitude: 0 to 3000 m (0 to 9843 ft), derate 1 % per 100 m (328 ft) between 1000 m and 3000 m (3281 ft and 9843 ft).
- Random Vibration: Tested in accordance with EN/IEC 60068-2-64 with SI and AI option modules fitted.

- Mechanical Shock: Tested in accordance with EN/IEC 60068-2-29.
- Electromagnetic Immunity complies with EN/IEC 61800-3 and EN/IEC 61000-6-2.
- With onboard EMC filter, complies with EN/IEC 61800-3 (2nd environment).
- EN/IEC 61000-6-3 and EN/IEC 61000-6-4 with optional footprint EMC filter.
- EN/IEC 60146-1-1 Supply conditions.
- EN/IEC 61800-5-1 Electrical Safety.
- EN/IEC 61131-2 I/O.
- Safe Torque Off, independently assessed by TÜV to EN/IEC 61800-5-2 SIL 3 and EN ISO 13849-1 PL_e.
- UL 508C Electrical Safety.

Optional keypads

Description/Order code
CI-Keypad
Remote Keypad

Optional accessories

Description/Order code
AI-Back-up Adaptor
AI-485 Adaptor
CI-485 Adaptor

Dimensions and Weight



Frame Size		1	2	3	4
Dimensions (H x W x D)	mm	137 x 75 x 130	180 x 75 x 150	200 x 90 x 160	245 x 115 x 175
	in	5.4 x 3.0 x 5.1	7.1 x 3.0 x 5.9	7.9 x 3.5 x 6.3	9.7 x 4.5 x 6.9
Weight	kg (lb)	0.75 (1.65)	1.0 (2.2)	1.5 (3.3)	3.13 (6.9)

Notes:

Height dimension (H) does not include mounting feet on sizes 1 to 4.

Additional distance should be added to the height dimension (H) when the following options are fitted on sizes 1 to 6:

- AI-Back-up Adaptor: 15 mm (0.59 in)
- AI-485 Adaptor: 26 mm (1.02 in)

Optional external EMC filters

Unidrive M built-in EMC filter complies with EN/IEC 61800-3 (2nd environment). External EMC filters are required for compliance with EN/IEC 61000-6-4 as per the table below.

Frame size	Voltage	Phases	Type	Order code
1	All	1	Standard	4200-1000
	All	1	Low leakage	4200-1001
2	100 V	1	Standard	4200-2000
		1	Low leakage	4200-2001
	200 V	1	Standard	4200-2002
		1	Low leakage	4200-2003
	400 V	3	Standard	4200-2004
		3	Low leakage	4200-2005
3	200 V	3	Standard	4200-3000
		3	Low leakage	4200-3001
		3	Standard	4200-3004
	400 V	3	Low leakage	4200-3005
		3	Standard	4200-3008
		3	Low leakage	4200-3009
4	200 V	1	Standard	4200-4000
		1	Low leakage	4200-4001
		3	Standard	4200-4002
	400 V	3	Low leakage	4200-4003
		3	Standard	4200-4004
5	200 V	3	Standard	4200-0312
	400 V	3	Standard	4200-0402
	575 V	3	Standard	4200-0122
6	200 V	3	Standard	4200-2300
	400 V	3	Standard	4200-4800
	575 V	3	Standard	4200-3690
7	200 V & 400 V	3	Standard	4200-1132
	690 V	3	Standard	4200-0672



	5	6	7	8	9*
	379x 141x 200	379 x 210 x 227	548 x 270 x 280	785 x 310 x 290	940 x 310 x 290
	14.9 x 5.6 x 7.9	14.9 x 8.3 x 8.9	21.6 x 10.6 x 11.0	30.9 x 12.2 x 11.4	37.0 x 12.2 x 11.4
	7.4 (16.3)	14 (30.9)	45 (99.2)	50 (110.2)	

* Future availability.

Conduit kit

When the following kits are fitted to the drive, it meets UL Type 1.

Frame size	Order code
1	3470-0091
2	3470-0094
3	3470-0098
4	3470-0102
5	3470-0069
6	3470-0059
7	3470-0080
8	3470-0088

Internal brake resistor

Frame size	Order code
5	1299-0003

Through hole IP65 kit

IP65 / UL TYPE 12 rating is achieved on the rear of the drive when through panel mounted using the following kits.

Frame size	Order code
5	3470-0067
6	3470-0055
7	3470-0079
8	3470-0083

Retrofit mounting brackets

These mounting brackets ensure the drive can be mounted on existing Commander SK installations.

Frame size	Order code
3	3470-0097
4	3470-0101
5	3470-0066
6	3470-0074
7	3470-0078
8	3470-0087

Fan replacement kit

Frame size	Order code
1	3470-0092
2	3470-0095
3	3470-0099
4	3470-0103

Cable grommet kit

Frame size	Order code
7	3470-0086
8	3470-0089 (Single cable)
	3470-0090 (Dual cable)

For a full list of patents and patent applications, visit www.controltechniques.com/patents.

CONTROL TECHNIQUES DRIVE & APPLICATION CENTERS

AUSTRALIA

Melbourne Application Center
T: +61 3 973 81777
controltechniques.au@emerson.com

Sydney Drive Center
T: +61 2 9838 7222
controltechniques.au@emerson.com

AUSTRIA

Linz Drive Center
T: +43 7229 789480
controltechniques.at@emerson.com

BELGIUM

Brussels Drive Center
T: +32 1574 0700
controltechniques.be@emerson.com

BRAZIL

Sorocaba Drive Center
T: +55 15 3413 8169
vendasbrasil.cta@emerson.com

CANADA

Toronto Application Center
T: +1 905 948 3402
controltechniques.ca@emerson.com

Calgary Drive Center
T: +1 403 253 8738
controltechniques.ca@emerson.com

CHILE

Santiago Application Center
T: +56 9 7708 9470
saleschile.cta@emerson.com

CHINA

Shanghai Drive Center
T: +86 21 3418 3888
controltechniques.cn@emerson.com

Shenzhen Application Center
T: +86 755 8618 7287
controltechniques.cn@emerson.com

CZECH REPUBLIC

Brno Drive Center
T: +420 511 180111
controltechniques.cz@emerson.com

DENMARK

Copenhagen Drive Center
T: +45 4369 6100
controltechniques.dk@emerson.com

FRANCE*

Angoulême Drive Center
T: +33 5 4564 5454
controltechniques.fr@emerson.com

GERMANY

Bonn Drive Center
T: +49 2242 8770
controltechniques.de@emerson.com

Chemnitz Drive Center
T: +49 3722 52030
controltechniques.de@emerson.com

Darmstadt Drive Center
T: +49 6251 17700
controltechniques.de@emerson.com

GREECE*

Athens Application Center
T: +00320 210 57 86086/088
controltechniques.gr@emerson.com

HOLLAND

Rotterdam Drive Center
T: +31 184 420555
controltechniques.nl@emerson.com

INDIA

Chennai Drive Center
T: +91 44 2496 1123/1130/1083
T: +91 44 6691 8400
controltechniques.in@emerson.com

IRELAND

Newbridge Drive Center
T: +353 45 448200
controltechniques.ie@emerson.com

ITALY

Milan Drive Center
T: +39 02575 751
controltechniques.it@emerson.com

Vicenza Drive Center
T: +39 0444 933400
controltechniques.it@emerson.com

MALAYSIA

Selangor Drive Center
T: +603 5891 6099
controltechniques.my@emerson.com

MEXICO

Mexico City Application Center
T: +52 155 3333 6666
salesmexico.cta@emerson.com

POLAND

Warsaw Application Center
T: +48 22 45 89 200
controltechniques.pl@emerson.com

REPUBLIC OF SOUTH AFRICA

Johannesburg Drive Center
T: +27 11 462 1740
controltechniques.za@emerson.com

Cape Town Application Center
T: +27 21 556 0245
controltechniques.za@emerson.com

RUSSIA

Moscow Application Center
T: +7 495 981 9811
controltechniques.ru@emerson.com

Chelyabinsk Application Center
T: +7 351 799 5151
controltechniques.ru@emerson.com

Saint Petersburg Application Center
T: +7 812 448 2063
controltechniques.ru@emerson.com

SINGAPORE

Singapore Drive Center
T: +65 6556 1100
controltechniques.sg@emerson.com

SLOVAKIA EMERSON A.S

T: +421 32 7700 369
controltechniques.sk@emerson.com

SOUTH KOREA

Seoul Application Center
T: +82 2 3483 1605
controltechniques.kr@emerson.com

SPAIN

Barcelona Drive Center
T: +34 93 680 1661
controltechniques.es@emerson.com

Bilbao Drive Center
T: +34 94 620 3646
controltechniques.es@emerson.com

Madrid Application Centre
T: +34 91 490 21 05
controltechniques.es@emerson.com

Valencia Drive Center
T: +34 96 154 2900
controltechniques.es@emerson.com

SWEDEN*

Stockholm Application Center
T: +468 554 241 00
controltechniques.se@emerson.com

SWITZERLAND

Zurich Drive Center
T: +41 56 201 4242
controltechniques.ch@emerson.com

Lausanne Application Center
T: +41 21 637 7070
controltechniques.fr.ch@emerson.com

TAIWAN

Taipei Application Center
T: +886 2 8161 7695
controltechniques.tw@emerson.com

THAILAND

Bangkok Drive Center
T: +66 2 962 2099
controltechniques.th@emerson.com

TURKEY

Istanbul Drive Center
T: +90 216 4182420
controltechniques.tr@emerson.com

UAE*

Emerson FZE
T: +971 4 8118100
ct.dubai@emerson.com

UKRAINE

Kiev Application Center
T: +380 44 492 99 29
controltechniques.ukr@emerson.com

UNITED KINGDOM

Telford Drive Center
T: +44 1952 213700
controltechniques.uk@emerson.com

USA

Charlotte Application Center
T: +1 800 893 2321
controltechniques.us@emerson.com

Cleveland Drive Center
T: +1 216 901 2400
controltechniques.us@emerson.com

Detroit Application Center
T: +1 248 882 2652
controltechniques.us@emerson.com

Minneapolis Drive Center
Americas Headquarters
T: +1 952 995 8000
controltechniques.us@emerson.com

Portland Drive Center
T: +1 503 266 2094
controltechniques.us@emerson.com

Providence Application Center
T: +1 401 392 4256
controltechniques.us@emerson.com

LATIN AMERICA

Miami Application Center
T: +1 954 846 5082
saleslatinam.cta@emerson.com



The Emerson logo is a trademark and a service mark of Emerson Electric Co. ©2013 Emerson Electric Co.

DRIVING THE WORLD...

CONTROL TECHNIQUES DISTRIBUTORS

ARGENTINA

Euro Techniques SA
T: +54 11 4331 7820
eurotech@eurotechsa.com.ar

BAHRAIN

Emerson FZE
T: +971 4 8118100
ct.bahrain@emerson.com

BULGARIA

BLS - Automation Ltd
T: +359 32 630 707
info@blsaautomation.com

COLOMBIA

Sistronic SAS
T: +57 2 555 6000
luis.alvarez@sistronic.com.co

Redes Electricas S.A.
T: +57 1 364 7000
alvaro.rodriguez@redeselectricas.com

Quimel Colombia S.A.
T: +57 1 357 5215
gerencia@quimelco.com

CROATIA

Zigg-Pro d.o.o.
T: +385 1 3463 000
zigg-pro@zg.hinet.hr

CYPRUS

Acme Industrial Electronic Services Ltd
T: +3572 5 332181
acme@cytanet.com.cy

DOMINICAN REPUBLIC

Puradom S.A.
T: +1 809 565 9599
franco@puradom.com

EGYPT

Samiram
T: +202 29703868/
+202 29703869
samiramz@samiram.com

EL SALVADOR

Servielectric Industrial S.A. de C.V.
T: +503 2278 1280
aeorellana@gruposervielectric.com

ECUADOR

Veltek Cia. Ltda.
T: +59 3 2326 4623
vacosta@veltek.com.ec

FINLAND

SKS Control
T: +358 207 6461
control@sksf.fi

GUATEMALA

MICE S.A.
T: +502 5510 2093
cesar.espana@miceautomation.com

HUNGARY

Control-VH Kft
T: +361 431 1160
info@controlvh.hu

ICELAND

Samey ehf
T: +354 510 5200
samey@samey.is

INDONESIA

PT. Apikon Indonesia
T: +65 6556 1100
controltechniques.sg@emerson.com

PT. Yusa Esa Sempurna Sejahtera

T: +65 6556 1100
controltechniques.sg@emerson.com

ISRAEL

Dor Drives Systems Ltd
T: +972 3900 7595
info@dor1.co.il

KENYA

Kassam & Bros Co. Ltd
T: +254 2 556 418
kassambros@africaonline.co.ke

KUWAIT

Emerson FZE
T: +971 4 8118100
ct.kuwait@emerson.com

LATVIA

EMT
T: +371 760 2026
janis@emt.lv

LEBANON

Black Box Automation & Control
T: +961 1 443773
info@blackboxcontrol.com

LITHUANIA

Elinta UAB
T: +370 37 351 987
sales@elinta.lt

MALTA

Mekanika Limited
T: +35621 442 039
mfranca@gasan.com

MOROCCO

Cietec
T: +212 22 354948
cietec@cietec.ma

NEW ZEALAND

Advanced Motor Control. Ph.
T: +64 (0) 274 363 067
info.au@controltechniques.com

PERU

Intech S.A.
T: +51 1 348 5858
ventas@intech-sa.com

Tecno Ingeniería Industrial SAC

T: +51 1 445 3608
jforero@tecnoing.com

PHILIPPINES

Control Techniques Singapore Pte. Ltd.
T: +65 68917600
controltechniques.sg@emerson.com

POLAND

APATOR CONTROL Sp. z o.o
T: +48 56 654 4900
info@acontrol.com.pl

PORTUGAL

HARKER SOLUTIONS, S.A.
Tel: +351 229 478 530
geral@harkersolutions.com

PUERTO RICO

Motion Industries Inc.
T: +1 787 251 1550
roberto.diaz@motion-ind.com

Control Associates of Puerto Rico LLC
T: +1 (787) 783 9200
pr-sales@control-associates.com

QATAR

Emerson FZE
T: +971 4 8118100
ct.qatar@emerson.com

ROMANIA

C.I.T. Automatizari
T: +40212550543
office@citautomatizari.ro

SAUDI ARABIA

A. Abunayyan Electric Corp.
T: +9661 477 9111
aec-salesmarketing@abunayyanguroup.com

SERBIA & MONTENEGRO

Master Inzenjering d.o.o
T: +381 24 525 235
office@masterinzenjering.rs

SLOVENIA

PS Logatec
T: +386 1 750 8510
ps-log@ps-log.si

URUGUAY

SECIOIN S.A.
T: +5982 2093815
jose.barron@secioin.com.uy

VENEZUELA

Digimex Sistemas C.A.
T: +58 243 551 1634
digimex@digimex.com.ve

VIETNAM

Nguyen Duc Thinh Technology & Trading Co. Ltd.
T: +84 8 3916 5601
infotech@nducthinh.com.vn